

STN	Plynárenská infraštruktúra. Plynovody na maximálny prevádzkový tlak do 16 barov vrátane. Časť 5: Prípojky. Špecifické funkčné požiadavky.	STN EN 12007-5 38 6409
------------	--	--

Gas infrastructure - Pipelines for maximum operating pressure up to and including 16 bar - Part 5: Service lines - Specific functional requirements

Táto norma obsahuje anglickú verziu európskej normy.
This standard includes the English version of the European Standard.

Táto norma bola oznámená vo Vestníku ÚNMS SR č. 10/14

Obsahuje: EN 12007-5:2014

119563

Úrad pre normalizáciu, metrológiu a skúšobníctvo SR, odbor SÚTN, 2014
Podľa zákona č. 264/1999 Z. z. v znení neskorších predpisov sa môžu slovenské technické normy rozmnožovať a rozširovať iba so súhlasom Úradu pre normalizáciu, metrológiu a skúšobníctvo SR.

EUROPEAN STANDARD

EN 12007-5

NORME EUROPÉENNE

EUROPÄISCHE NORM

April 2014

ICS 23.040.01

English Version

Gas infrastructure - Pipelines for maximum operating pressure up to and including 16 bar - Part 5: Service lines - Specific functional requirements

Infrastructures gazières - Canalisations pour pression maximale de service inférieure ou égale à 16 bar - Partie 5: Branchements - Recommandations fonctionnelles spécifiques

Gasinfrastruktur - Rohrleitungen mit einem maximal zulässigen Betriebsdruck bis einschließlich 16 bar - Teil 5: Hausanschlussleitungen - Spezifische funktionale Anforderungen

This European Standard was approved by CEN on 8 February 2014.

CEN members are bound to comply with the CEN/CENELEC Internal Regulations which stipulate the conditions for giving this European Standard the status of a national standard without any alteration. Up-to-date lists and bibliographical references concerning such national standards may be obtained on application to the CEN-CENELEC Management Centre or to any CEN member.

This European Standard exists in three official versions (English, French, German). A version in any other language made by translation under the responsibility of a CEN member into its own language and notified to the CEN-CENELEC Management Centre has the same status as the official versions.

CEN members are the national standards bodies of Austria, Belgium, Bulgaria, Croatia, Cyprus, Czech Republic, Denmark, Estonia, Finland, Former Yugoslav Republic of Macedonia, France, Germany, Greece, Hungary, Iceland, Ireland, Italy, Latvia, Lithuania, Luxembourg, Malta, Netherlands, Norway, Poland, Portugal, Romania, Slovakia, Slovenia, Spain, Sweden, Switzerland, Turkey and United Kingdom.



EUROPEAN COMMITTEE FOR STANDARDIZATION
COMITÉ EUROPÉEN DE NORMALISATION
EUROPÄISCHES KOMITEE FÜR NORMUNG

CEN-CENELEC Management Centre: Avenue Marnix 17, B-1000 Brussels

Contents		Page
Introduction		5
1 Scope		6
2 Normative references		7
3 Terms and definitions		8
3.1 General terminology		8
3.2 Pressure related terminology		10
4 Design		10
4.1 General.....		10
4.2 Protection		11
4.3 Materials and components		12
4.3.1 General.....		12
4.3.2 Isolation valve		12
4.3.3 Flow limiting device.....		13
4.3.4 Venting devices.....		13
4.3.5 Regulators and meters		13
4.4 Service line routing.....		13
4.4.1 External routing		13
4.4.2 Wall and floor transition.....		13
4.4.3 Internal routing.....		14
4.5 Pipe sizing		15
4.6 Identification.....		15
5 Construction.....		15
5.1 General.....		15
5.2 Storage, handling and transportation.....		16
5.3 Service line installation		16
5.4 Connections to existing gas infrastructure		17
6 Quality control.....		17
6.1 Quality management system		17
6.2 Inspection prior to installation		17
6.3 Inspection during installation.....		17
6.3.1 Ground conditions.....		17
6.3.2 Joint integrity		18
6.4 Competence		18
7 Pressure testing.....		18
7.1 General.....		18
7.2 Safety during pressure testing.....		19
7.3 Prior to testing		19
7.4 Test mediums.....		19
7.5 Measurement equipment		19
7.6 Strength test.....		19
7.7 Tightness test.....		20
7.8 Failed pressure test.....		20
8 Commissioning and decommissioning.....		21
8.1 General.....		21
8.2 Purging		21
9 Operation and maintenance		21
9.1 General.....		21

9.2	Record system and traceability	22
Annex A	(normative) Jointing methods.....	23
A.1	General	23
A.2	Threaded joints.....	23
A.3	Fusion, welded, brazed and soldered joints.....	23
A.4	Mechanical joints.....	23
A.5	Pressed joints	23
A.5.1	General	23
A.5.2	Pressed joints for copper pipe.....	24
	Bibliography.....	25

Foreword

This document (EN 12007-5:2014) has been prepared by Technical Committee CEN/TC 234 "Gas infrastructure", the secretariat of which is held by DIN.

This European Standard shall be given the status of a national standard, either by publication of an identical text or by endorsement, at the latest by October 2014 and conflicting national standards shall be withdrawn at the latest by October 2014.

Attention is drawn to the possibility that some of the elements of this document may be the subject of patent rights. CEN [and/or CENELEC] shall not be held responsible for identifying any or all such patent rights.

This document has been prepared under a mandate given to CEN by the European Commission and the European Free Trade Association, and supports essential requirements of EU Directive(s).

This European Standard is part of the series EN 12007 "Gas infrastructure — Pipelines for maximum operating pressure up to and including 16 bar" which comprises the following parts:

- *Part 1 General functional requirements;*
- *Part 2 Specific functional requirements for polyethylene (MOP up to and including 10 bar);*
- *Part 3 Specific functional requirements for steel;*
- *Part 4 Specific functional requirements for renovation;*
- *Part 5 Specific functional recommendations of new service lines.*

According to the CEN-CENELEC Internal Regulations, the national standards organizations of the following countries are bound to implement this European Standard: Austria, Belgium, Bulgaria, Croatia, Cyprus, Czech Republic, Denmark, Estonia, Finland, Former Yugoslav Republic of Macedonia, France, Germany, Greece, Hungary, Iceland, Ireland, Italy, Latvia, Lithuania, Luxembourg, Malta, Netherlands, Norway, Poland, Portugal, Romania, Slovakia, Slovenia, Spain, Sweden, Switzerland, Turkey and the United Kingdom.

Introduction

This European Standard describes the general functional requirements for gas supply through service line pipe systems and covers the pressure range up to and including 16 bar maximum operating pressure (MOP). It gives normative and informative references for safe and secure gas infrastructures. It applies to their design, construction, operation and the related aspects of safety, environment and public health, all in order to provide a safe and secure supply of gas.

This European Standard is intended to be used in addition to the EN 12007 series of European Standards.

The requirements of this European Standard are based on safe gas engineering practice under conditions normally encountered in the gas industry. Requirements for all unusual conditions cannot be specifically provided for, nor are all engineering and construction details prescribed.

Existing industrial safety regulations applying to work areas, safety devices and safe work practices are not intended to be supplanted by this European Standard.

Persons responsible for the design, construction and operation of gas infrastructures should have regard to the guidance given in this European Standard, the EN 12007 series of European Standards and to other relevant standards. It is the responsibility of these persons to apply these functional requirements, supplemented with other proven good practice to the particular circumstances of each gas infrastructure.

The recommendations in this European Standard are intended to be applied by competent persons who have suitable knowledge and experience. Notes in the text are informative.

The designer, constructor or operator of service line and pipeline systems is cautioned that this European Standard is not a design handbook or code of practice. Additional national or company standards describing the details are needed. These detailed standards should be in line with the basic principles of this European Standard.

All pressures are gauge pressure unless stated otherwise.

In preparing this European Standard it was recognised that the suite of relevant European Standards is incomplete. Reference may be made where appropriate to international, national or other standards until relevant European Standards are available.

1 Scope

This European Standard describes the specific functional requirements for service lines in addition to the general functional requirements of EN 12007-1 for:

- a maximum operating pressure (MOP) up to and including 16 bar;
- an operating temperature between $-20\text{ }^{\circ}\text{C}$ and $+40\text{ }^{\circ}\text{C}$.

It applies to their design, construction, commissioning, decommissioning, operation, maintenance, extension and other associated works. The service line is the physical asset comprising of pipework from the gas main branch saddle or top tee to the outlet of the distribution system operator's nominated point(s) of delivery (for example: isolation valve, regulator, meter connection or combination of regulator and isolation valve).

The ownership and operation responsibility can vary between member states. The extent of the service line can differ in each member state. To illustrate this, the various points of deliveries are indicated in Figure 1. Consult Figure 1 (A/B/C/D/E) and member state regulations and standards.

NOTE The valve at point A is not necessarily utilised by each member state.

National preference for points of deliveries should be stated in the national foreword.

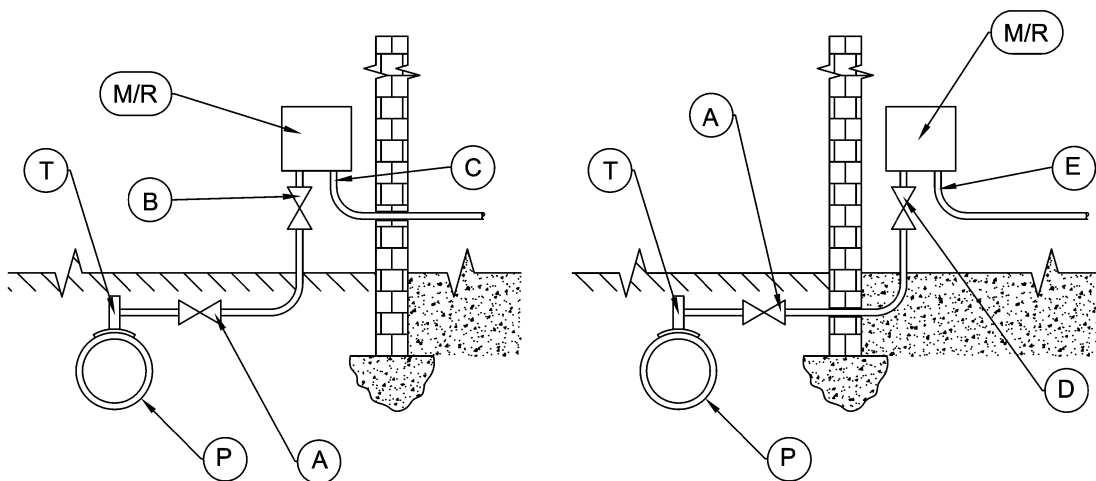

Key

P gas main
T Top Tee / Branch Saddle
M/R Meter and/or Regulator

Distribution system operator nominated Point(s) of Delivery:
A outlet of below ground service line valve outside the building
B outlet of above ground service line valve outside the building
C outlet of meter/regulator outside the building
D outlet of above ground service line valve inside the building
E outlet of meter/regulator inside the building

Figure 1 — Distribution system operator nominated point of delivery

Specific functional requirements for:

- polyethylene pipelines are given in EN 12007-2.
- steel pipelines are given in EN 12007-3.
- pipework for buildings are given in EN 1775.

- pressure regulating installations are given in EN 12279 or EN 12186.
- pressure testing, commissioning and decommissioning are given in EN 12327.

This European Standard represents the recommendations at the time of its preparation. It does not apply retrospectively to installations before the publication date unless specifically stated.

This European Standard specifies common basic principles for gas infrastructure. Users of this European Standard should be aware that more detailed national standards and/or code of practice may exist in the CEN member countries. This European Standard is intended to be applied in association with these national standards and/or codes of practice setting out the above-mentioned basic principles.

In the event of conflicts in terms of more restrictive requirements in national legislation/regulation with the requirements of this European Standard, the national legislation/regulation takes precedence as illustrated in CEN/TR 13737 (all parts).

CEN/TR 13737 (all parts) gives:

- clarification of all legislations/regulations applicable in a member state;
- if appropriate, more restrictive national requirements;
- a national contact point for the latest information.

2 Normative references

The following documents, in whole or in part, are normatively referenced in this document and are indispensable for its application. For dated references, only the edition cited applies. For undated references, the latest edition of the referenced document (including any amendments) applies.

EN 751-1, *Sealing materials for metallic threaded joints in contact with 1st, 2nd and 3rd family gases and hot water - Part 1: Anaerobic jointing compounds*

EN 751-2, *Sealing materials for metallic threaded joints in contact with 1st, 2nd and 3rd family gases and hot water - Part 2: Non-hardening jointing compounds*

EN 751-3, *Sealing materials for metallic threaded joints in contact with 1st, 2nd and 3rd family gases and hot water - Part 3: Unsintered PTFE tapes.*

EN 1057, *Copper and copper alloys - Seamless, round copper tubes for water and gas in sanitary and heating applications*

EN 1254 (all parts), *Copper and copper alloys — Plumbing fittings*

EN 1775:2007, *Gas supply - Gas pipework for buildings - Maximum operating pressure less than or equal to 5 bar - Functional recommendations*

EN 1776, *Gas supply systems - Natural gas measuring stations - Functional requirements*

EN 10226-1, *Pipe threads where pressure tight joints are made on the threads - Part 1: Taper external threads and parallel internal threads - Dimensions, tolerances and designation*

EN 10226-2, *Pipe threads where pressure tight joints are made on the threads - Part 2: Taper external threads and taper internal threads - Dimensions, tolerances and designation*

EN 10241, *Steel threaded pipe fittings*

EN 12007-5:2014 (E)

EN 10242, *Threaded pipe fitting in malleable cast iron*

EN 12007-1:2012, *Gas infrastructure - Pipelines for maximum operating pressure up to and including 16 bar - Part 1: General functional requirements*

EN 12007-2:2012, *Gas infrastructure - Pipelines for maximum operating pressure up to and including 16 bar - Part 2: Specific functional requirements for polyethylene (MOP up to and including 10 bar)*

EN 12007-3, *Gas infrastructure - Pipelines for maximum operating pressure up to and including 16 bar - Part 3: Specific functional recommendations for steel*

EN 12186, *Gas supply systems - Gas pressure regulating stations for transmission and distribution - Functional requirements*

EN 12279, *Gas supply systems - Gas pressure regulating installations on service lines - Functional requirements*

EN 12327, *Gas infrastructure - Pressure testing, commissioning and decommissioning procedures - Functional requirements*

konec náhľadu – text ďalej pokračuje v platenej verzii STN