

STN	Formát na výmenu technických údajov pri projektovaní priemyselných riadiacich systémov. Časť 1: Architektúra a všeobecné požiadavky.	STN EN 62714-1
		18 4022

Engineering data exchange format for use in industrial automation systems engineering - Part 1: Architecture and General Requirements

Táto norma obsahuje anglickú verziu európskej normy.
This standard includes the English version of the European Standard.

Táto norma bola oznámená vo Vestníku ÚNMS SR č. 03/15

Obsahuje: EN 62714-1:2014, IEC 62714-1:2014

120299

Úrad pre normalizáciu, metrológiu a skúšobníctvo SR, odbor SÚTN, 2015
Podľa zákona č. 264/1999 Z. z. v znení neskorších predpisov sa môžu slovenské technické normy rozmnožovať a rozširovať iba so súhlasom Úradu pre normalizáciu, metrológiu a skúšobníctvo SR.

EUROPEAN STANDARD

EN 62714-1

NORME EUROPÉENNE

EUROPÄISCHE NORM

October 2014

ICS 25.040.40; 35.060; 35.240.50

English Version

Engineering data exchange format for use in industrial
automation systems engineering - Part 1: Architecture and
General Requirements
(IEC 62714-1:2014)

Format d'échange de données techniques pour une
utilisation dans l'ingénierie des systèmes d'automatisation
industrielle - AutomationML - Partie 1: Architecture et
exigences générales
(CEI 62714-1:2014)

Datenaustauschformat für Planungsdaten industrieller
Automatisierungssysteme (AutomationML) - Teil 1:
Architektur und allgemeine Festlegungen
(IEC 62714-1:2014)

This European Standard was approved by CENELEC on 2014-07-31. CENELEC members are bound to comply with the CEN/CENELEC Internal Regulations which stipulate the conditions for giving this European Standard the status of a national standard without any alteration.

Up-to-date lists and bibliographical references concerning such national standards may be obtained on application to the CEN-CENELEC Management Centre or to any CENELEC member.

This European Standard exists in three official versions (English, French, German). A version in any other language made by translation under the responsibility of a CENELEC member into its own language and notified to the CEN-CENELEC Management Centre has the same status as the official versions.

CENELEC members are the national electrotechnical committees of Austria, Belgium, Bulgaria, Croatia, Cyprus, the Czech Republic, Denmark, Estonia, Finland, Former Yugoslav Republic of Macedonia, France, Germany, Greece, Hungary, Iceland, Ireland, Italy, Latvia, Lithuania, Luxembourg, Malta, the Netherlands, Norway, Poland, Portugal, Romania, Slovakia, Slovenia, Spain, Sweden, Switzerland, Turkey and the United Kingdom.



European Committee for Electrotechnical Standardization
Comité Européen de Normalisation Electrotechnique
Europäisches Komitee für Elektrotechnische Normung

CEN-CENELEC Management Centre: Avenue Marnix 17, B-1000 Brussels

Foreword

The text of document 65E/385/FDIS, future edition 1 of IEC 62714-1, prepared by SC 65E "Devices and integration in enterprise systems" of IEC/TC 65 "Industrial-process measurement, control and automation" was submitted to the IEC-CENELEC parallel vote and approved by CENELEC as EN 62714-1:2014.

The following dates are fixed:

- latest date by which the document has to be implemented at national level by publication of an identical national standard or by endorsement (dop) 2015-05-01
- latest date by which the national standards conflicting with the document have to be withdrawn (dow) 2017-07-31

Attention is drawn to the possibility that some of the elements of this document may be the subject of patent rights. CENELEC [and/or CEN] shall not be held responsible for identifying any or all such patent rights.

This document has been prepared under a mandate given to CENELEC by the European Commission and the European Free Trade Association.

Endorsement notice

The text of the International Standard IEC 62714-1:2014 was approved by CENELEC as a European Standard without any modification.

In the official version, for Bibliography, the following notes have to be added for the standards indicated:

IEC 60027 (Series)	NOTE	Harmonized as EN 60027 (Series).
IEC 62264-1	NOTE	Harmonized as EN 62264-1.
IEC 62714-2	NOTE	Harmonized as EN 62714-2
ISO 80000-1	NOTE	Harmonized as EN ISO 80000-1.

Annex ZA (normative)

Normative references to international publications with their corresponding European publications

The following documents, in whole or in part, are normatively referenced in this document and are indispensable for its application. For dated references, only the edition cited applies. For undated references, the latest edition of the referenced document (including any amendments) applies.

NOTE 1 When an International Publication has been modified by common modifications, indicated by (mod), the relevant EN/HD applies.

NOTE 2 Up-to-date information on the latest versions of the European Standards listed in this annex is available here: www.cenelec.eu.

<u>Publication</u>	<u>Year</u>	<u>Title</u>	<u>EN/HD</u>	<u>Year</u>
IEC 62424	2008	Representation of process control engineering - Requests in P&I diagrams and data exchange between P&ID tools and PCE-CAE tools	EN 62424	2009
IEC 62714	series	Engineering data exchange format for use in industrial automation systems engineering	EN 62714	series
ISO/IEC 9834-8	-	Information technology - Procedures for the operation of object identifier registration authorities: General procedures and top arcs of the international object identifier tree	-	-
ISO/PAS 17506	-	Industrial automation systems and integration - COLLADA digital asset schema specification for 3D visualization of industrial data	-	-



INTERNATIONAL STANDARD

NORME INTERNATIONALE



**Engineering data exchange format for use in industrial automation systems
engineering – Automation markup language –
Part 1: Architecture and general requirements**

**Format d'échange de données techniques pour une utilisation dans l'ingénierie
des systèmes d'automatisation industrielle – Automation markup language –
Partie 1: Architecture et exigences générales**



THIS PUBLICATION IS COPYRIGHT PROTECTED

Copyright © 2014 IEC, Geneva, Switzerland

All rights reserved. Unless otherwise specified, no part of this publication may be reproduced or utilized in any form or by any means, electronic or mechanical, including photocopying and microfilm, without permission in writing from either IEC or IEC's member National Committee in the country of the requester. If you have any questions about IEC copyright or have an enquiry about obtaining additional rights to this publication, please contact the address below or your local IEC member National Committee for further information.

Droits de reproduction réservés. Sauf indication contraire, aucune partie de cette publication ne peut être reproduite ni utilisée sous quelque forme que ce soit et par aucun procédé, électronique ou mécanique, y compris la photocopie et les microfilms, sans l'accord écrit de l'IEC ou du Comité national de l'IEC du pays du demandeur. Si vous avez des questions sur le copyright de l'IEC ou si vous désirez obtenir des droits supplémentaires sur cette publication, utilisez les coordonnées ci-après ou contactez le Comité national de l'IEC de votre pays de résidence.

IEC Central Office
3, rue de Varembe
CH-1211 Geneva 20
Switzerland

Tel.: +41 22 919 02 11
Fax: +41 22 919 03 00
info@iec.ch
www.iec.ch

About the IEC

The International Electrotechnical Commission (IEC) is the leading global organization that prepares and publishes International Standards for all electrical, electronic and related technologies.

About IEC publications

The technical content of IEC publications is kept under constant review by the IEC. Please make sure that you have the latest edition, a corrigenda or an amendment might have been published.

IEC Catalogue - webstore.iec.ch/catalogue

The stand-alone application for consulting the entire bibliographical information on IEC International Standards, Technical Specifications, Technical Reports and other documents. Available for PC, Mac OS, Android Tablets and iPad.

IEC publications search - www.iec.ch/searchpub

The advanced search enables to find IEC publications by a variety of criteria (reference number, text, technical committee,...). It also gives information on projects, replaced and withdrawn publications.

IEC Just Published - webstore.iec.ch/justpublished

Stay up to date on all new IEC publications. Just Published details all new publications released. Available online and also once a month by email.

Electropedia - www.electropedia.org

The world's leading online dictionary of electronic and electrical terms containing more than 30 000 terms and definitions in English and French, with equivalent terms in 14 additional languages. Also known as the International Electrotechnical Vocabulary (IEV) online.

IEC Glossary - std.iec.ch/glossary

More than 55 000 electrotechnical terminology entries in English and French extracted from the Terms and Definitions clause of IEC publications issued since 2002. Some entries have been collected from earlier publications of IEC TC 37, 77, 86 and CISPR.

IEC Customer Service Centre - webstore.iec.ch/csc

If you wish to give us your feedback on this publication or need further assistance, please contact the Customer Service Centre: csc@iec.ch.

A propos de l'IEC

La Commission Electrotechnique Internationale (IEC) est la première organisation mondiale qui élabore et publie des Normes internationales pour tout ce qui a trait à l'électricité, à l'électronique et aux technologies apparentées.

A propos des publications IEC

Le contenu technique des publications IEC est constamment revu. Veuillez vous assurer que vous possédez l'édition la plus récente, un corrigendum ou amendement peut avoir été publié.

Catalogue IEC - webstore.iec.ch/catalogue

Application autonome pour consulter tous les renseignements bibliographiques sur les Normes internationales, Spécifications techniques, Rapports techniques et autres documents de l'IEC. Disponible pour PC, Mac OS, tablettes Android et iPad.

Recherche de publications IEC - www.iec.ch/searchpub

La recherche avancée permet de trouver des publications IEC en utilisant différents critères (numéro de référence, texte, comité d'études,...). Elle donne aussi des informations sur les projets et les publications remplacées ou retirées.

IEC Just Published - webstore.iec.ch/justpublished

Restez informé sur les nouvelles publications IEC. Just Published détaille les nouvelles publications parues. Disponible en ligne et aussi une fois par mois par email.

Electropedia - www.electropedia.org

Le premier dictionnaire en ligne de termes électroniques et électriques. Il contient plus de 30 000 termes et définitions en anglais et en français, ainsi que les termes équivalents dans 14 langues additionnelles. Egalement appelé Vocabulaire Electrotechnique International (IEV) en ligne.

Glossaire IEC - std.iec.ch/glossary

Plus de 55 000 entrées terminologiques électrotechniques, en anglais et en français, extraites des articles Termes et Définitions des publications IEC parues depuis 2002. Plus certaines entrées antérieures extraites des publications des CE 37, 77, 86 et CISPR de l'IEC.

Service Clients - webstore.iec.ch/csc

Si vous désirez nous donner des commentaires sur cette publication ou si vous avez des questions contactez-nous: csc@iec.ch.



IEC 62714-1

Edition 1.0 2014-06

INTERNATIONAL STANDARD

NORME INTERNATIONALE



**Engineering data exchange format for use in industrial automation systems
engineering – Automation markup language –
Part 1: Architecture and general requirements**

**Format d'échange de données techniques pour une utilisation dans l'ingénierie
des systèmes d'automatisation industrielle – Automation markup language –
Partie 1: Architecture et exigences générales**

INTERNATIONAL
ELECTROTECHNICAL
COMMISSION

COMMISSION
ELECTROTECHNIQUE
INTERNATIONALE

PRICE CODE **XC**
CODE PRIX

ICS 25.040.40; 35.06; 35.240.50

ISBN 978-2-8322-1554-8

**Warning! Make sure that you obtained this publication from an authorized distributor.
Attention! Veuillez vous assurer que vous avez obtenu cette publication via un distributeur agréé.**

CONTENTS

FOREWORD.....	7
INTRODUCTION.....	9
1 Scope.....	11
2 Normative references	11
3 Terms, definitions and abbreviations	11
3.1 Terms and definitions.....	11
3.2 Abbreviations.....	14
4 Conformity.....	14
5 AML architecture specification	15
5.1 General.....	15
5.2 General AML architecture	15
5.3 AML document versions.....	16
5.4 Meta information about the AML source tool	17
5.5 Object identification	18
5.6 AML relations specification	19
5.6.1 General	19
5.6.2 Parent-child-relations between AML objects	19
5.6.3 Parent-child-relations between AML classes	20
5.6.4 Inheritance relations	21
5.6.5 Class-instance-relations	21
5.6.6 Instance-instance-relations	23
5.7 AML document reference specification.....	25
5.7.1 General	25
5.7.2 Referencing COLLADA documents	25
5.7.3 Referencing PLCopen XML documents.....	25
5.7.4 Referencing additional documents	25
6 AML base libraries.....	25
6.1 General.....	25
6.2 General provisions	25
6.3 AML interface class library – AutomationMLInterfaceClassLib.....	26
6.3.1 General	26
6.3.2 InterfaceClass AutomationMLBaseInterface.....	28
6.3.3 InterfaceClass Order	28
6.3.4 InterfaceClass PortConnector	29
6.3.5 InterfaceClass PPRConnector	29
6.3.6 InterfaceClass ExternalDataConnector	29
6.3.7 InterfaceClass COLLADAInterface	30
6.3.8 InterfaceClass PLCopenXMLInterface	30
6.3.9 InterfaceClass Communication	30
6.3.10 InterfaceClass SignalInterface	31
6.4 AML basic role class library – AutomationMLBaseRoleClassLib.....	31
6.4.1 General	31
6.4.2 RoleClass AutomationMLBaseRole.....	33
6.4.3 RoleClass Group	33
6.4.4 RoleClass Facet	34

6.4.5	RoleClass Port	34
6.4.6	RoleClass Resource	36
6.4.7	RoleClass Product	36
6.4.8	RoleClass Process	37
6.4.9	RoleClass Structure	37
6.4.10	RoleClass ProductStructure	37
6.4.11	RoleClass ProcessStructure	38
6.4.12	RoleClass ResourceStructure	38
6.4.13	RoleClass PropertySet	38
7	Modelling of user-defined data	39
7.1	General	39
7.2	User-defined attributes	39
7.3	User-defined InterfaceClasses	39
7.4	User-defined RoleClasses	40
7.5	User-defined SystemUnitClasses	41
7.6	User-defined InstanceHierarchies	41
8	Extended AML concepts	42
8.1	General overview	42
8.2	AML Port object	42
8.3	AML Facet object	43
8.4	AML Group object	43
8.5	AML PropertySet	44
8.6	Support of multiple roles	46
8.7	Splitting of AML top-level data into different documents	47
8.8	Internationalization	47
8.9	Version information of AML objects	47
Annex A (informative)	General introduction into the Automation Markup Language	48
A.1	General Automation Markup Language concepts	48
A.1.1	The Automation Markup Language architecture	48
A.1.2	Modelling of plant topology information	50
A.1.3	Referencing geometry and kinematics information	51
A.1.4	Referencing logic information	51
A.1.5	Modelling of relations	52
A.2	Extended AML concepts and examples	55
A.2.1	General overview	55
A.2.2	AML Port concept	55
A.2.3	AML Facet concept	59
A.2.4	AML Group concept	61
A.2.5	PropertySet concept	65
A.2.6	Process-Product-Resource concept	68
A.2.7	Support of multiple roles	76
Annex B (informative)	XML Representation of AML Libraries	80
B.1	AutomationMLBaseRoleClassLib	80
B.2	AutomationMLInterfaceClassLib	81
	Bibliography	82
	Figure 1 – Overview of the engineering data exchange format AML	9
	Figure 2 – AML document version information	16

Figure 3 – XML text of the AML source tool information	18
Figure 4 – Object identification example of an AML class.....	19
Figure 5 – Object identification example of an AML object instance	19
Figure 6 – Example of a parent-child-relation between AML objects.....	20
Figure 7 – Example of a parent-child-relation between classes	20
Figure 8 – Example of an inheritance relation between two classes	21
Figure 9 – Example of a class-instance-relation	22
Figure 10 – Example of a relation as block diagram and as object tree	23
Figure 11 – Example relation between the objects “PLC1” and “Rob1”	24
Figure 12 – AML basic interface class library.....	27
Figure 13 – XML description of the AML basic interface class library	28
Figure 14 – AML basic role class library.....	32
Figure 15 – AutomationMLBaseRoleClassLib.....	32
Figure 16 – XML text of the AutomationMLBaseRoleClassLib	33
Figure 17 – Example of a user-defined attribute.....	39
Figure 18 – Example of a user-defined InterfaceClass in a user-defined InterfaceClassLib.....	40
Figure 19 – Example of a user-defined RoleClass in a user-defined RoleClassLib	41
Figure 20 – Examples for different user-defined SystemUnitClasses	41
Figure 21 – Example of a user-defined InstanceHierarchy.....	42
Figure 22 – AML representation of a user-defined InstanceHierarchy.....	42
Figure 23 – Example illustrating the PropertySet concept	45
Figure 24 – XML text of the PropertySet example	46
Figure A.1 – AML general architecture	48
Figure A.2 – Plant topology with AML	50
Figure A.3 – Reference from CAEX to a COLLADA document.....	51
Figure A.4 – Reference from a CAEX to a PLCopen XML document	52
Figure A.5 – Relations in AML.....	53
Figure A.6 – XML description of the relations example.....	54
Figure A.7 – XML text of the SystemUnitClassLib of the relations example	54
Figure A.8 – XML text of the InstanceHierarchy of the relations example	54
Figure A.9 – Port concept	55
Figure A.10 – Example describing the AML Port concept	56
Figure A.11 – XML description of the AML Port concept.....	57
Figure A.12 – XML text describing the AML Port concept.....	58
Figure A.13 – Definition of a user-defined AML Port class “myPortClass”.....	58
Figure A.14 – AML Facet example	60
Figure A.15 – XML text of the AML Facet example.....	60
Figure A.16 – AML Group example	61
Figure A.17 – XML text for the AML Group example.....	62
Figure A.18 – Combination of the Facet and Group concept.....	63
Figure A.19 – XML text view for the combined Facet-Group example.....	64
Figure A.20 – Generic HMI template “B” visualizing a process variable “Y” of a conveyor.....	65

Figure A.21 – Generated HMI result “B” visualizing both conveyors with individual process variables.....	65
Figure A.22 – PropertySet example.....	66
Figure A.23 – PropertySet example.....	66
Figure A.24 – XML text for the instance hierarchy.....	67
Figure A.25 – PropertySet example AML library as XML code.....	68
Figure A.26 – Base elements of the Product-Process-Resource concept.....	69
Figure A.27 – PPRConnector interface.....	70
Figure A.28 – Example for the Product-Process-Resource concept.....	70
Figure A.29 – AML roles required for the Process-Product-Resource concept.....	71
Figure A.30 – Elements of the example.....	71
Figure A.31 – Links within the example.....	72
Figure A.32 – Links of the resource centric view on the example.....	73
Figure A.33 – InstanceHierarchy of the example in AML.....	74
Figure A.34 – InternalElements of the example.....	75
Figure A.35 – InternalLinks of the example.....	75
Figure A.36 – InstanceHierarchy of the example in XML.....	76
Figure A.37 – Example of a user-defined instance supporting multiple roles.....	77
Figure A.38 – XML text of the AML representation of multiple role support.....	78
Figure A.39 – AML Role class library corresponding to the multiple role definition example.....	78
Figure A.40 – XML text of the AML role class library.....	79
Table 1 – Abbreviations.....	14
Table 2 – Meta information about the AML source tool.....	17
Table 3 – Interface classes of the AutomationMLInterfaceClassLib.....	26
Table 4 – InterfaceClass AutomationMLBaseInterface.....	28
Table 5 – InterfaceClass Order.....	28
Table 6 – InterfaceClass PortConnector.....	29
Table 7 – InterfaceClass PPRConnector.....	29
Table 8 – InterfaceClass ExternalDataConnector.....	29
Table 9 – InterfaceClass COLLADAInterface.....	30
Table 10 – InterfaceClass PLCopenXMLInterface.....	30
Table 11 – InterfaceClass Communication.....	31
Table 12 – InterfaceClass SignalInterface.....	31
Table 13 – RoleClass AutomationMLBaseRole.....	33
Table 14 – RoleClass Group.....	34
Table 15 – RoleClass Facet.....	34
Table 16 – Optional attributes for AML Port objects.....	35
Table 17 – Sub-attributes of the attribute “Cardinality”.....	35
Table 18 – Interface of the AML Port class.....	36
Table 19 – RoleClass Resource.....	36
Table 20 – RoleClass Product.....	36
Table 21 – RoleClass Process.....	37

Table 22 – RoleClass Structure	37
Table 23 – RoleClass ProductStructure	37
Table 24 – RoleClass ProcessStructure	38
Table 25 – RoleClass ResourceStructure	38
Table 26 – RoleClass PropertySet	38
Table A.1 – Overview of major extended AML concepts	55

INTERNATIONAL ELECTROTECHNICAL COMMISSION

**ENGINEERING DATA EXCHANGE FORMAT FOR USE
IN INDUSTRIAL AUTOMATION SYSTEMS ENGINEERING –
AUTOMATION MARKUP LANGUAGE –**
Part 1: Architecture and general requirements

FOREWORD

- 1) The International Electrotechnical Commission (IEC) is a worldwide organization for standardization comprising all national electrotechnical committees (IEC National Committees). The object of IEC is to promote international co-operation on all questions concerning standardization in the electrical and electronic fields. To this end and in addition to other activities, IEC publishes International Standards, Technical Specifications, Technical Reports, Publicly Available Specifications (PAS) and Guides (hereafter referred to as "IEC Publication(s)"). Their preparation is entrusted to technical committees; any IEC National Committee interested in the subject dealt with may participate in this preparatory work. International, governmental and non-governmental organizations liaising with the IEC also participate in this preparation. IEC collaborates closely with the International Organization for Standardization (ISO) in accordance with conditions determined by agreement between the two organizations.
- 2) The formal decisions or agreements of IEC on technical matters express, as nearly as possible, an international consensus of opinion on the relevant subjects since each technical committee has representation from all interested IEC National Committees.
- 3) IEC Publications have the form of recommendations for international use and are accepted by IEC National Committees in that sense. While all reasonable efforts are made to ensure that the technical content of IEC Publications is accurate, IEC cannot be held responsible for the way in which they are used or for any misinterpretation by any end user.
- 4) In order to promote international uniformity, IEC National Committees undertake to apply IEC Publications transparently to the maximum extent possible in their national and regional publications. Any divergence between any IEC Publication and the corresponding national or regional publication shall be clearly indicated in the latter.
- 5) IEC itself does not provide any attestation of conformity. Independent certification bodies provide conformity assessment services and, in some areas, access to IEC marks of conformity. IEC is not responsible for any services carried out by independent certification bodies.
- 6) All users should ensure that they have the latest edition of this publication.
- 7) No liability shall attach to IEC or its directors, employees, servants or agents including individual experts and members of its technical committees and IEC National Committees for any personal injury, property damage or other damage of any nature whatsoever, whether direct or indirect, or for costs (including legal fees) and expenses arising out of the publication, use of, or reliance upon, this IEC Publication or any other IEC Publications.
- 8) Attention is drawn to the Normative references cited in this publication. Use of the referenced publications is indispensable for the correct application of this publication.
- 9) Attention is drawn to the possibility that some of the elements of this IEC Publication may be the subject of patent rights. IEC shall not be held responsible for identifying any or all such patent rights.

International Standard IEC 62714-1 has been prepared by subcommittee 65E: Devices and integration in enterprise systems, of IEC technical committee 65: Industrial-process measurement, control and automation.

The text of this standard is based on the following documents:

FDIS	Report on voting
65E/385/FDIS	65E/396/RVD

Full information on the voting for the approval of this standard can be found in the report on voting indicated in the above table.

This publication has been drafted in accordance with the ISO/IEC Directives, Part 2.

A list of all parts in the IEC 62714 series, published under the general title *Engineering data exchange format for use in industrial automation systems engineering – Automation Markup Language*, can be found on the IEC website.

The committee has decided that the contents of this publication will remain unchanged until the stability date indicated on the IEC web site under "<http://webstore.iec.ch>" in the data related to the specific publication. At this date, the publication will be

- reconfirmed,
- withdrawn,
- replaced by a revised edition, or
- amended.

IMPORTANT – The 'colour inside' logo on the cover page of this publication indicates that it contains colours which are considered to be useful for the correct understanding of its contents. Users should therefore print this document using a colour printer.

INTRODUCTION

IEC 62714 is a solution for data exchange focusing on the domain of automation engineering.

The data exchange format defined in the IEC 62714 series (Automation Markup Language, AML) is an XML schema based data format and has been developed in order to support the data exchange in a heterogeneous engineering tools landscape.

The goal of AML is to interconnect engineering tools in their different disciplines, e.g. mechanical plant engineering, electrical design, process engineering, process control engineering, HMI development, PLC programming, robot programming, etc.

AML stores engineering information following the object oriented paradigm and allows modelling of physical and logical plant components as data objects encapsulating different aspects. An object may consist of other sub-objects, and may itself be part of a larger composition or aggregation. Typical objects in plant automation comprise information on topology, geometry, kinematics and logic, whereas logic comprises sequencing, behaviour and control. Therefore, an important focus in the data exchange in engineering is the exchange of object oriented data structures, geometry, kinematics and logic.

AML combines existing industry data formats that are designed for the storage and exchange of different aspects of engineering information. These data formats are used on an “as-is” basis within their own specifications and are not branched for AML needs.

The core of AML is the top-level data format CAEX that connects the different data formats. Therefore, AML has an inherent distributed document architecture.

Figure 1 illustrates the basic AML architecture and the distribution of topology, geometry, kinematics and logic information.

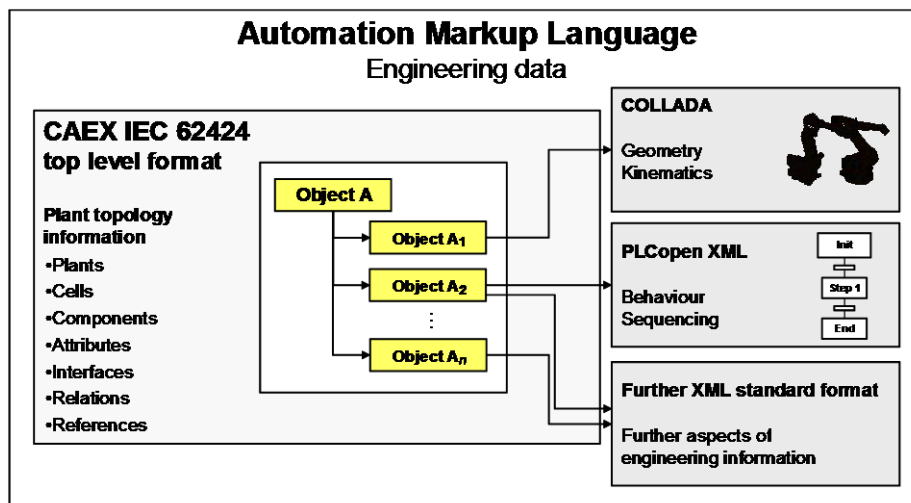

Figure 1 – Overview of the engineering data exchange format AML

Due to the different aspects of AML, the IEC 62714 series consists of different parts focussing on different aspects:

- IEC 62714-1: Architecture and general requirements

This part specifies the general AML architecture, the modelling of engineering data, classes, instances, relations, references, hierarchies, basic AML libraries and extended AML concepts. It is the basis of all future parts, and it provides mechanisms to reference other sub formats.

- IEC 62714-2: Role class libraries
This part is intended to specify additional AML libraries.
- IEC 62714-3: Geometry and kinematics
This part is intended to specify the modelling of geometry and kinematics information.
- IEC 62714-4: Logic
This part is intended to specify the modelling of logics, sequencing, behaviour and control related information.

Further parts may be added in the future in order to interconnect further data standards to AML.

As long as no further parts describe the integration of further standards, it is important to focus on a limited set of sub data formats. Otherwise it would open up the usage of any data format and data exchange would not work.

Annex A gives an informative introduction, use cases and examples regarding AML.

Annex B gives an informative XML representation of the libraries defined in this part of IEC 62714.

ENGINEERING DATA EXCHANGE FORMAT FOR USE IN INDUSTRIAL AUTOMATION SYSTEMS ENGINEERING – AUTOMATION MARKUP LANGUAGE –

Part 1: Architecture and general requirements

1 Scope

This part of IEC 62714 specifies general requirements and the architecture of AML for the modelling of engineering information which is exchanged between engineering tools for industrial automation and control systems. Its provisions apply to the export/import applications of related tools.

This part of IEC 62714 does not define details of the data exchange procedure or implementation requirements for the import/export tools.

2 Normative references

The following documents, in whole or in part, are normatively referenced in this document and are indispensable for its application. For dated references, only the edition cited applies. For undated references, the latest edition of the referenced document (including any amendments) applies.

IEC 62424:2008, *Representation of process control engineering – Requests in P&I diagrams and data exchange between P&ID tools and PCE-CAE tools*

IEC 62714 (all parts), *Engineering data exchange format for use in industrial automation systems engineering – Automation Markup Language*

ISO/IEC 9834-8, *Information technology – Open Systems Interconnection – Procedures for the operation of OSI Registration Authorities: Generation and registration of Universally Unique Identifiers (UUIDs) and their use as ASN.1 Object Identifier components*

ISO/PAS 17506, *Industrial automation systems and integration — COLLADA digital asset schema specification for 3D visualization of industrial data*

COLLADA 1.4.1:March 2008, COLLADA – Digital Asset Schema Release 1.4.1
(available at <http://www.khronos.org/files/collada_spec_1_4.pdf>)

Extensible Markup Language (XML) 1.0 1.0:2004, W3C Recommendation
(available at <<http://www.w3.org/TR/2004/REC-xml-20040204/>>)

PLCopen XML 2.0:December 3rd 2008 and PLCopen XML 2.0.1:May 8th 2009, XML formats for IEC 61131-3
(available at <<http://www.plcopen.org/>>)

koniec náhľadu – text ďalej pokračuje v platenej verzii STN