

STN	Potravinárske stroje. Plniace a pomocné stroje. Bezpečnostné a hygienické požiadavky.	STN EN 12463 51 3050
------------	--	--

Food processing machinery - Filling machines and auxiliary machines - Safety and hygiene requirements

Táto norma obsahuje anglickú verziu európskej normy.
This standard includes the English version of the European Standard.

Táto norma bola oznámená vo Vestníku ÚNMS SR č. 04/15

Obsahuje: EN 12463:2014

Oznámením tejto normy sa ruší
STN EN 12463+A1 (51 3050) z júla 2011

120690

Úrad pre normalizáciu, metrológiu a skúšobníctvo SR, odbor SÚTN, 2015
Podľa zákona č. 264/1999 Z. z. v znení neskorších predpisov sa môžu slovenské technické normy
rozmnožovať a rozširovať iba so súhlasom Úradu pre normalizáciu, metrológiu a skúšobníctvo SR.

English Version

Food processing machinery - Filling machines and auxiliary machines - Safety and hygiene requirements

Machines pour les produits alimentaires - Machines à pousser et machines auxiliaires - Prescriptions relatives à la sécurité et l'hygiène

Nahrungsmittelmaschinen - Füllmaschinen und Vorsatzmaschinen - Sicherheits- und Hygieneanforderungen

This European Standard was approved by CEN on 13 September 2014.

CEN members are bound to comply with the CEN/CENELEC Internal Regulations which stipulate the conditions for giving this European Standard the status of a national standard without any alteration. Up-to-date lists and bibliographical references concerning such national standards may be obtained on application to the CEN-CENELEC Management Centre or to any CEN member.

This European Standard exists in three official versions (English, French, German). A version in any other language made by translation under the responsibility of a CEN member into its own language and notified to the CEN-CENELEC Management Centre has the same status as the official versions.

CEN members are the national standards bodies of Austria, Belgium, Bulgaria, Croatia, Cyprus, Czech Republic, Denmark, Estonia, Finland, Former Yugoslav Republic of Macedonia, France, Germany, Greece, Hungary, Iceland, Ireland, Italy, Latvia, Lithuania, Luxembourg, Malta, Netherlands, Norway, Poland, Portugal, Romania, Slovakia, Slovenia, Spain, Sweden, Switzerland, Turkey and United Kingdom.



EUROPEAN COMMITTEE FOR STANDARDIZATION
COMITÉ EUROPÉEN DE NORMALISATION
EUROPÄISCHES KOMITEE FÜR NORMUNG

CEN-CENELEC Management Centre: Avenue Marnix 17, B-1000 Brussels

Contents

Page

Foreword.....	4
Introduction	5
1 Scope	6
1.1 General.....	6
1.2 Types of filling machines and auxiliary machines covered by this standard	8
1.2.1 Filling machines with cylinder with piston	8
1.2.2 Filling machines with feed intake hopper with and without loading device.....	8
1.2.3 Auxiliary machines for filling machines	9
1.3 Combinations of filling machines and auxiliary machines, devices/modules and interchangeable equipment	12
1.3.1 Definition	12
1.3.2 Examples of combinations	12
2 Normative references	13
3 Terms and definitions	15
4 List of significant hazards	17
5 Safety and hygiene requirements and/or protective measures	22
5.1 General.....	22
5.2 Mechanical hazards – General	22
5.2.1 General.....	22
5.2.2 Guard interlocking	22
5.2.3 Cutting hazards.....	23
5.2.4 ON-/OFF-switch.....	23
5.3 Mechanical hazards distinguished from type.....	23
5.3.1 Filling machines with cylinder with piston	23
5.3.2 Filling machines with feed intake hopper	25
5.3.3 Loading devices.....	30
5.3.4 Auxiliary machines	33
5.3.5 Drive system – Zone 22.....	39
5.3.6 Machine components – Zone 23	39
5.4 Electrical hazards	39
5.4.1 General.....	39
5.4.2 Emergency stop device.....	39
5.4.3 Protection against water ingress	39
5.4.4 Safety requirements related to electromagnetic phenomena	41
5.5 Hazard from loss of stability.....	41
5.6 Noise reduction.....	41
5.7 Ergonomic requirements	41
5.8 Hygiene and cleaning.....	42
5.8.1 General.....	42
5.8.2 Filling machines.....	42
5.8.3 Auxiliary machines	44
5.8.4 Surface conditions.....	45
5.8.5 Cleaning.....	45
5.8.6 Cutting hazards.....	45
6 Verification of safety and hygiene requirements and/or protective measures	45
7 Information for use	48
7.1 General.....	48

7.2	Instruction handbook	48
7.3	Marking	51
7.3.1	Marking of machinery	51
7.3.2	Marking of devices or modules	51
7.3.3	Marking of interchangeable equipment	51
7.4	Intended use	52
Annex A	(normative) Noise test code for filling machines and auxiliary machines (grade 2)	53
A.1	Determination of the emission sound pressure level	53
A.2	Installation and mounting conditions	53
A.3	Operating conditions	53
A.4	Measurement	53
A.5	Information to be recorded	54
A.6	Information to be reported	54
A.7	Declaration and verification of the noise emission values	54
Annex B	(normative) Design principles to ensure the cleanability of filling machines and auxiliary machines	55
B.1	Definitions	55
B.2	Materials of construction	56
B.3	Design	56
	Bibliography	62

Foreword

This document (EN 12463:2014) has been prepared by Technical Committee CEN/TC 153 "Machinery intended for use with foodstuffs and feed", the secretariat of which is held by DIN.

This European Standard shall be given the status of a national standard, either by publication of an identical text or by endorsement, at the latest by May 2015 and conflicting national standards shall be withdrawn at the latest by May 2015.

Attention is drawn to the possibility that some of the elements of this document may be the subject of patent rights. CEN [and/or CENELEC] shall not be held responsible for identifying any or all such patent rights.

This document supersedes EN 12463:2004+A1:2011.

This document has been prepared under a mandate given to CEN by the European Commission and the European Free Trade Association, and supports essential requirements of EU Directive 2006/42/EC.

For relationship with EU Directive 2006/42/EC, see informative Annex ZA, which is an integral part of this document.

Significant changes:

The significant changes with respect to the previous edition EN 12463:2004+A1:2011 are listed below:

- Clause 1: the scope now contains a list of auxiliary machines, auxiliary devices and interchangeable equipment and their combinations with a filling machine; displacement of requirements in the appropriate clauses; old 1.3 "Intended use" has been shifted into 7.4;
- Clause 2: normative references updated;
- Clause 3: terms partly unified, revised, supplemented (e.g. dividing device, hanging device, loading device, fixing device, machine, auxiliary machine, device, module, interchangeable equipment); consistent use throughout the standard;
- Clause 4: new presentation in a table;
- Clause 5: extensive 5.2 with new title "Mechanical hazards – General", more specific requirements in 5.3 with new title "Mechanical hazards distinguished from type" (e.g. stopping time, cover over feed intake hopper, steps and ladders, static and dynamic test, auxiliary machines, ergonomic requirements);
- Clause 6: verification list updated;
- Clause 7: completion of 7.2 with all information referred to in Clause 5, now including operator training and combination of machines; 7.3 now contains also the marking of devices and interchangeable equipment;
- Annexes: old Annex C "Common hazard" deleted and shifted into appropriate clauses;
- Figures partly renewed.

According to the CEN-CENELEC Internal Regulations, the national standards organizations of the following countries are bound to implement this European Standard: Austria, Belgium, Bulgaria, Croatia, Cyprus, Czech Republic, Denmark, Estonia, Finland, Former Yugoslav Republic of Macedonia, France, Germany, Greece, Hungary, Iceland, Ireland, Italy, Latvia, Lithuania, Luxembourg, Malta, Netherlands, Norway, Poland, Portugal, Romania, Slovakia, Slovenia, Spain, Sweden, Switzerland, Turkey and the United Kingdom.

Introduction

This document is a type C standard as stated in EN ISO 12100.

The machinery concerned and the extent to which hazards, hazardous situations and hazardous events are covered are indicated in the scope of this document.

When provisions of this type C standard are different from those which are stated in type A or B standards, the provisions of this type C standard take precedence over the provisions of the other standards, for machines that have been designed and built according to the provisions of this type C standard.

1 Scope

1.1 General

This European Standard applies for:

- filling machines with cylinder with piston,
- filling machines with feed intake hopper with and without loading device,
- auxiliary machines for filling machines.

This European Standard does not apply to filling machines with cylinder and manual operation.

This European Standard applies to machines which process pasty or slightly frozen products (e.g. meat, cheese), excluding dry or deep frozen materials. They pump foodstuff into casings or bring it to a subsequent process. This European Standard also applies to the combinable appliances or auxiliary machines with which a wide range of additional functions can be implemented, for example: portioning, depositing, mincing, coextruding, dividing and forming.

This European Standard deals with all significant hazards, hazardous situations and events relevant to filling machines, fitting appliances and auxiliary machines, such as twisting and hanging devices, mincing devices, forming devices, etc., when they are used as intended and under the conditions foreseen by the manufacturer and also the reasonable foreseeable misuse (see Clause 4).

These significant hazards, hazardous situations and events exist during the whole life of filling machines.

This European Standard covers the following auxiliary machines, auxiliary devices and interchangeable equipment:

- a) auxiliary machines:
 - 1) portioning machine;
 - 2) twisting machine;
 - 3) mincing machine;
 - 4) calibrating machine;
 - 5) separation machine;
 - 6) hanging machine;
 - 7) co-extrusion machine;
 - 8) tying machine;
 - 9) grouping machine;
 - 10) filling stream divider machine;
 - 11) depositing machine;
 - 12) forming machine;
 - 13) peeling machine;

- 14) (casing-) spooling machine;
 - 15) evacuating machine;
 - 16) loading machine;
 - 17) insertion machine;
 - 18) handling machine (for full smoke sticks, single products or product groups);
- b) auxiliary devices / modules:
- 1) portioning device / module;
 - 2) twisting device / module;
 - 3) mincing device / module;
 - 4) calibrating device / module;
 - 5) separating device / module;
 - 6) hanging device / module;
 - 7) co-extrusion device / module;
 - 8) tying device / module;
 - 9) filling stream divider device / module;
 - 10) depositor device / module;
 - 11) forming device / module;
 - 12) peeling device / module;
 - 13) (casing-) spooling device / module;
 - 14) casing loading device / module;
 - 15) evacuation device / module;
 - 16) casing closing device / module;
 - 17) loading device / module;
 - 18) ejector device / module;
- c) interchangeable equipment:
- 1) linking gear box;
 - 2) holding device;
 - 3) mincing attachment;
 - 4) nozzles;

EN 12463:2014 (E)

- 5) casing brakes;
- 6) separating unit;
- 7) reservoir / infeed hopper;
- 8) depositor;
- 9) voider unit;
- 10) dosing valve;
- 11) grinding sets;
- 12) forming inserts.

This European Standard is not applicable to filling machines and auxiliary machines which are manufactured before the date of publication of this document by CEN.

Filling machines described in this European Standard are no forming, filling and sealing machines as described in EN 415-3. Clipping machines are not covered by this document.

1.2 Types of filling machines and auxiliary machines covered by this standard

1.2.1 Filling machines with cylinder with piston

Filling machines with cylinder consist of piston, closing cover, machine frame accessory drive parts and electrical and hydraulic components (see Figure 1).

The material being processed will be fed by hand into the cylinder.

Filling machines with cylinder can be fitted with a dividing device.

1.2.2 Filling machines with feed intake hopper with and without loading device

Filling machines with feed intake hopper (with or without infeed auger, see Figure 2) consist of feeder on discharge side of the feed intake hopper, machine frame, accessory drive parts and electric, electronic or pneumatic components, depending on machine type.

The material being processed will be fed by hand or a loading device into the feeding hopper of the filling machine.

Filling machines will be switched on or off by knee-operated lever switches or hand operated switches and/or remote control signals.

Filling machines with feed intake hopper can be equipped with:

- dividing device,
- cover or photoelectric guard at the mouth of the feed intake hopper,
- pressure activated trip bar or light barrier at the hopper edge,
- divided hopper,
- plough or counter auger,
- step or ladder,

- two hand control at the mouth of the feed intake hopper,
- loading device.

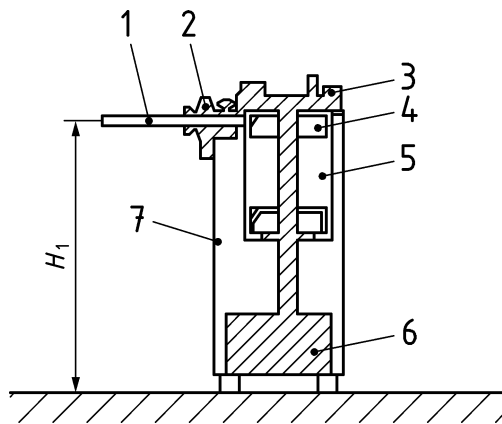
**Key**

- 1 filling horn
- 2 dividing device
- 3 closing cover
- 4 piston
- 5 cylinder
- 6 drive mechanism
- 7 ON / OFF switch, hood

Figure 1 — Filling machine with cylinder and piston

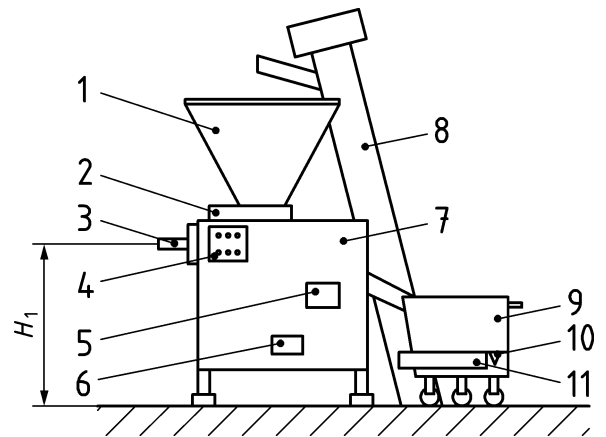
**Key**

- 1 feed intake hopper
- 2 feeder
- 3 filling horn
- 4 ON / OFF switch, hood
- 5 step
- 6 intermediate step
- 7 drive mechanism
- 8 mast-type loading device
- 9 transport car
- 10 fixing device
- 11 loading device

Figure 2 — Filling machine with feed intake hopper and loading device

1.2.3 Auxiliary machines for filling machines

Auxiliary machines consist of a drive system and at least of one of the following devices for filling, portioning, twisting, displacing, forming, mincing (e.g. see Figures 3 to 8). Auxiliary machines do not operate independently. These machines will be actuated directly or by filling machines.

Auxiliary machines will be switched on or off by knee-operated lever switches or hand operated switches and/or remote control signals.

Auxiliary machines can be fitted with:

- dividing device,
- hanging device.

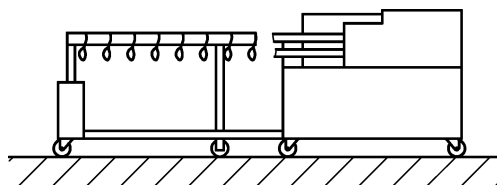
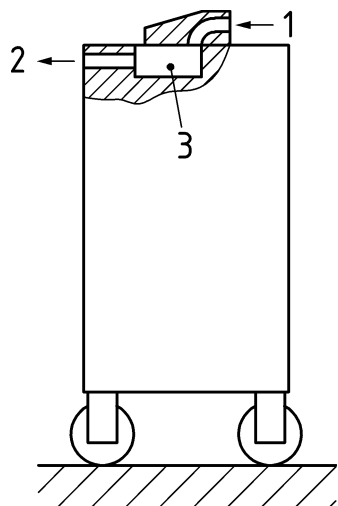

Key

- 1 inlet
- 2 outlet
- 3 feeder

Figure 3 — Auxiliary twisting device

Figure 4 — Auxiliary portioning and hanging device

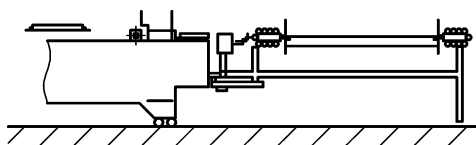

Figure 5 — Auxiliary portioning and hanging device

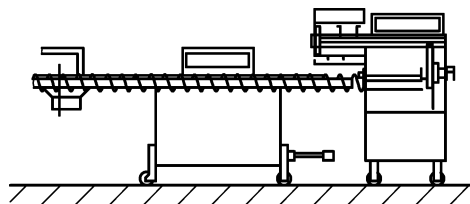
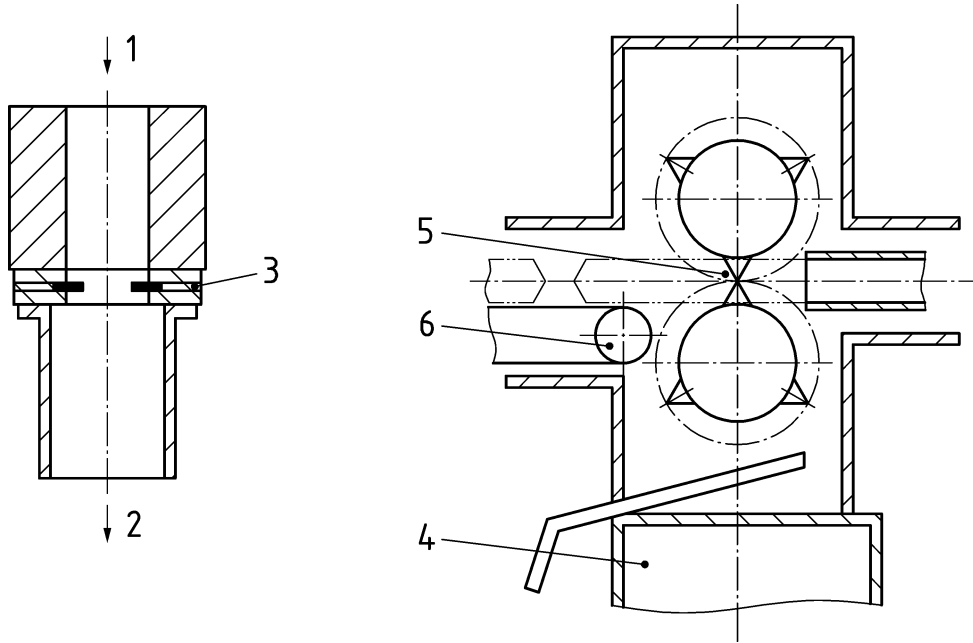

Figure 6 — Auxiliary portioning and hanging device



Key

- | | |
|------------------|------------------|
| 1 inlet | 4 base |
| 2 outlet | 5 forming device |
| 3 forming device | 6 conveyor belt |

Figure 7 — Auxiliary forming devices

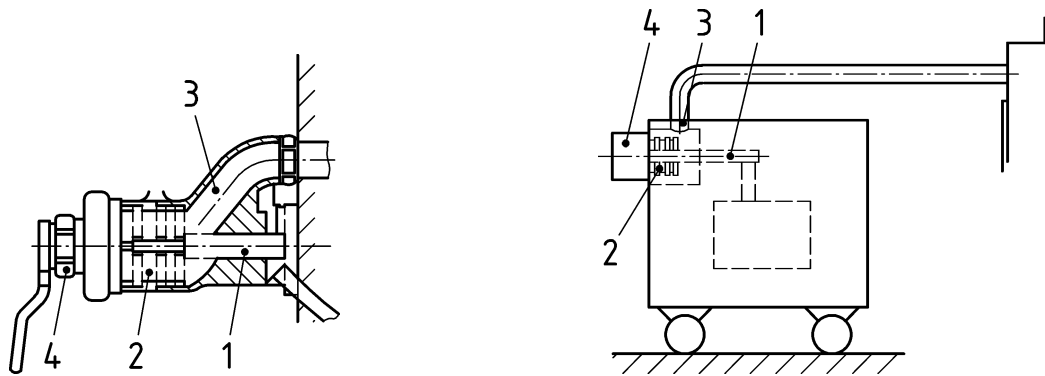

Key

- 1 drive shaft
 2 set of cutting tools
 3 feed intake canal
 4 nut/plate

Key

- 1 drive shaft
 2 cutting tools
 3 feed intake canal
 4 locking/plate

a) Driven by the filling machines

b) With direct drive

Figure 8 — Auxiliary mincing machine

EN 12463:2014 (E)**1.3 Combinations of filling machines and auxiliary machines, devices/modules and interchangeable equipment****1.3.1 Definition**

A combination of filling machines with auxiliary machines, auxiliary devices/modules and interchangeable equipment or a combination of some auxiliary machines or one auxiliary machine with auxiliary devices/modules and/or interchangeable equipment becomes a new machine, when following requirements are fulfilled / met:

- the (combined) device/equipment works together as an entity, meaning from production related view they form an entity (i.e. the coaction will be focused on a shared aim) and
- they are controlled as an entity, via a shared or linked control system and
- they work, regarding safety, together as an entity and also form a unit in this aspect.

According to this definition a new machine is not existent, when in a total complex, single autonomous functional machines are connected in relation to function and control but do not form a unit in relation to safety. This is given e.g. when:

- on the single interfaces / interconnection points none ore only minor hazards between the separate machines occur, due to their combination;
- emergency stop of one machine is connected / looped through to the next machine since the operator's position is only at the next machine.

In such mechanical equipment each single machine can still be regarded autonomous in relation to safety.

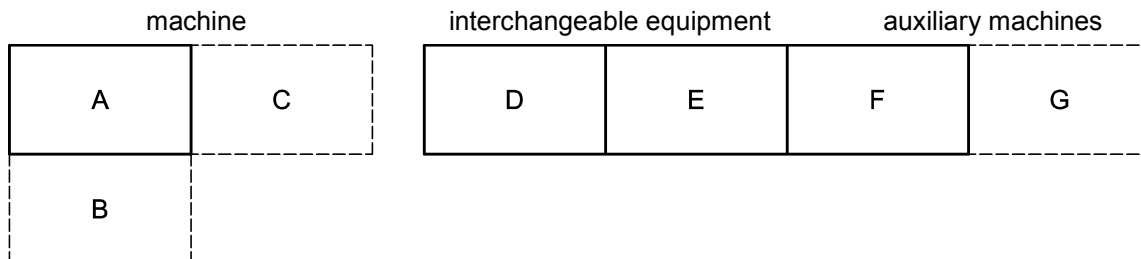
1.3.2 Examples of combinations**Key**

A	filling machine	D	twisting module	F	separating module
B	loading device (optional)	E	calibrating module	G	hanging module (optional)
C	mincing device (optional)				

a) Filling machine with auxiliary machines consisting of different modules

EN 12463:2014 (E)

- EN 614-1, *Safety of machinery — Ergonomic design principles — Part 1: Terminology and general principles*
- EN 953:1997+A1:2009, *Safety of machinery — Guards — General requirements for the design and construction of fixed and movable guards*
- EN 1005-1, *Safety of machinery — Human physical performance — Part 1: Terms and definitions*
- EN 1005-2, *Safety of machinery — Human physical performance — Part 2: Manual handling of machinery and component parts of machinery*
- EN 1005-3, *Safety of machinery — Human physical performance — Part 3: Recommended force limits for machinery operation*
- EN 1672-2:2005+A1:2009, *Food processing machinery — Basic concepts — Part 2: Hygiene requirements*
- EN 60204-1:2006, *Safety of machinery — Electrical equipment of machines — Part 1: General requirements (IEC 60204-1:2005, modified)*
- EN 60529, *Degrees of protection provided by enclosures (IP Code) (IEC 60529)*
- EN 61496-1, *Safety of machinery — Electro-sensitive protective equipment — Part 1: General requirements and tests (IEC 61496-1)*
- EN ISO 3744:2010, *Acoustics — Determination of sound power levels and sound energy levels of noise sources using sound pressure — Engineering methods for an essentially free field over a reflecting plane (ISO 3744:2010)*
- EN ISO 4871, *Acoustics v Declaration and verification of noise emission values of machinery and equipment (ISO 4871)*
- EN ISO 11201:2010, *Acoustics — Noise emitted by machinery and equipment — Determination of emission sound pressure levels at a work station and at other specified positions in an essentially free field over a reflecting plane with negligible environmental corrections (ISO 11201:2010)*
- EN ISO 11688-1, *Acoustics — Recommended practice for the design of low-noise machinery and equipment — Part 1: Planning (ISO/TR 11688-1)*
- EN ISO 12100:2010, *Safety of machinery — General principles for design — Risk assessment and risk reduction (ISO 12100:2010)*
- EN ISO 13849-1, *Safety of machinery — Safety-related parts of control systems — Part 1: General principles for design (ISO 13849-1)*
- EN ISO 13855, *Safety of machinery — Positioning of safeguards with respect to the approach speeds of parts of the human body (ISO 13855)*
- EN ISO 13857:2008, *Safety of machinery — Safety distances to prevent hazard zones being reached by upper and lower limbs (ISO 13857:2008)*
- EN ISO 14119:2013, *Safety of machinery — Interlocking devices associated with guards — Principles for design and selection (ISO 14119:2013)*
- EN ISO 14122-3, *Safety of machinery — Permanent means of access to machinery — Part 3: Stairs, stepladders and guard-rails (ISO 14122-3)*

koniec náhľadu – text ďalej pokračuje v platenej verzii STN