

STN	Informačná technika. Zariadenia a infraštruktúry výpočtových stredísk. Časť 2-4: Infraštruktúra telekomunikačného káblového rozvodu.	STN EN 50600-2-4 36 7254
------------	---	--

Information technology - Data centre facilities and infrastructures - Part 2-4: Telecommunications cabling infrastructure

Táto norma obsahuje anglickú verziu európskej normy.
This standard includes the English version of the European Standard.

Táto norma bola oznámená vo Vestníku ÚNMS SR č. 08/15

Obsahuje: EN 50600-2-4:2015

121395



Úrad pre normalizáciu, metrológiu a skúšobníctvo SR, 2015
Podľa zákona č. 264/1999 Z. z. v znení neskorších predpisov sa môžu slovenské technické normy rozmnožovať a rozširovať iba so súhlasom Úradu pre normalizáciu, metrológiu a skúšobníctvo SR.

ICS 35.020; 35.110; 35.160

English Version

Information technology - Data centre facilities and infrastructures - Part 2-4: Telecommunications cabling infrastructure

Technologie de l'information - Installation et infrastructures
de centres de traitement de données - Partie 2-4:
Infrastructure du câblage dédié télécommunications

Informationstechnik - Einrichtungen und Infrastrukturen von
Rechenzentren - Teil 2-4: Infrastruktur der
Telekommunikationsverkabelung

This European Standard was approved by CENELEC on 2015-02-16. CENELEC members are bound to comply with the CEN/CENELEC Internal Regulations which stipulate the conditions for giving this European Standard the status of a national standard without any alteration.

Up-to-date lists and bibliographical references concerning such national standards may be obtained on application to the CEN-CENELEC Management Centre or to any CENELEC member.

This European Standard exists in three official versions (English, French, German). A version in any other language made by translation under the responsibility of a CENELEC member into its own language and notified to the CEN-CENELEC Management Centre has the same status as the official versions.

CENELEC members are the national electrotechnical committees of Austria, Belgium, Bulgaria, Croatia, Cyprus, the Czech Republic, Denmark, Estonia, Finland, Former Yugoslav Republic of Macedonia, France, Germany, Greece, Hungary, Iceland, Ireland, Italy, Latvia, Lithuania, Luxembourg, Malta, the Netherlands, Norway, Poland, Portugal, Romania, Slovakia, Slovenia, Spain, Sweden, Switzerland, Turkey and the United Kingdom.



European Committee for Electrotechnical Standardization
Comité Européen de Normalisation Electrotechnique
Europäisches Komitee für Elektrotechnische Normung

CEN-CENELEC Management Centre: Avenue Marnix 17, B-1000 Brussels

Content

Foreword	5
Introduction	6
1 Scope	8
2 Normative references	8
3 Terms, definitions and abbreviations	9
3.1 Terms and definitions	9
3.2 Abbreviations.....	10
4 Conformance	11
5 Telecommunications cabling within the data centre	11
5.1 General.....	11
5.2 Information technology and network telecommunications cabling in the computer room space.....	14
5.3 Structured cabling for other data centre spaces and application specific structured cabling	16
6 Availability design principles for telecommunications cabling infrastructure	17
7 Availability classification for telecommunications cabling infrastructure	17
7.1 General.....	17
7.2 Telecommunications cabling for the computer room	18
7.3 Telecommunications cabling for offices	22
7.4 Telecommunications cabling for monitoring and control.....	22
8 Pathways and pathway systems for telecommunications cabling	22
8.1 General.....	22
8.2 Pathways.....	23
8.3 Pathway systems	24
9 Cabinets and racks for the computer room space	25
9.1 General requirements.....	25
9.2 Requirements for dimensions	25
9.3 Recommendations	25
10 Documentation and quality plan	25
10.1 Requirements for documentation	25
10.2 Recommendations for documentation	25
10.3 Requirements for the quality plan	26
11 Management and operation of the telecommunications cabling infrastructure	26
11.1 General.....	26
11.2 Automated infrastructure management systems	26
11.3 Fibre optic cabling	26
Annex A (normative) Cabling design concepts	27
A.1 General	27

A.2 Class 1 cabling concept	27
A.3 Class 2 cabling concepts	28
A.4 Class 3 cabling concepts	30
A.5 Class 4 cabling concepts	32
Annex B (informative) Energy efficiency considerations for the telecommunications cabling infrastructure	35
Bibliography.....	36
Figures	
Figure 1 - Schematic relationship between the EN 50600 standards	7
Figure 2 – Impact of growth in an unstructured point-to-point cabling infrastructure	13
Figure 3 – Example of point-to-point cabling.....	13
Figure 4 – Structured cabling infrastructure: setup and growth	14
Figure 5 – Data centre cabling subsystems according to EN 50173-5	15
Figure 6 – Office cabling subsystems according to EN 50173-2	15
Figure 7 – Building service cabling subsystem according to EN 50173-6	16
Figure 8 – Telecommunication cabling Class 1 using direct attached cords	18
Figure 9 – Transmission channels (interconnect and cross-connect).....	19
Figure 10 – ENI redundancy for Class 1 and 2	19
Figure 11 – Managing moves, adds and changes	20
Figure 12 - Redundant multipath telecommunication cabling Class 3	20
Figure 13 - Redundant multipath telecommunication cabling Class 4	21
Figure A.1 – Symbols of network elements.....	27
Figure A.2 – Example of a Class 1 cabling implementation.....	27
Figure A.3 – Example for Class 2 EoR cabling implementation.....	28
Figure A.4 – Example for Class 2 MoR cabling implementation	29
Figure A.5 – Example for Class 2 ToR cabling implementation.....	30
Figure A.6 – Example for Class 3 EoR cabling implementation.....	31
Figure A.7 – Example for Class 3 ToR cabling implementation.....	32
Figure A.8 – Example for Class 4 EoR cabling implementation.....	33

Figure A.9 – Example for Class 4 ToR cabling implementation34

Tables

Table 1 – Telecommunication cabling Availability Classes per space architecture and overall data centre
Availability Class for facilities and infrastructures 18

Foreword

This document (EN 50600-2-4:2015) has been prepared by CLC/TC 215 "Electrotechnical aspects of telecommunication equipment".

The following dates are fixed:

- latest date by which this document has to be implemented at national level by publication of an identical national standard or by endorsement (dop) 2016-02-16
- latest date by which the national standards conflicting with this document have to be withdrawn (dow) 2018-02-16

Attention is drawn to the possibility that some of the elements of this document may be the subject of patent rights. CENELEC [and/or CEN] shall not be held responsible for identifying any or all such patent rights.

This document has been prepared under a mandate given to CENELEC by the European Commission and the European Free Trade Association.

Introduction

The unrestricted access to internet-based information demanded by the information society has led to an exponential growth of both internet traffic and the volume of stored/retrieved data. Data centres are housing and supporting the information technology and network telecommunications equipment for data processing, data storage and data transport. They are required both by network operators (delivering those services to customer premises) and by enterprises within those customer premises.

Data centres need to provide modular, scalable and flexible facilities and infrastructures to easily accommodate the rapidly changing requirements of the market. In addition, energy consumption of data centres has become critical both from an environmental point of view (reduction of carbon footprint) and with respect to economical considerations (cost of energy) for the data centre operator.

The implementation of data centres varies in terms of:

- a) purpose (enterprise, co-location, co-hosting or network operator facilities);
- b) security level;
- c) physical size;
- d) accommodation (mobile, temporary and permanent constructions).

The needs of data centres also vary in terms of availability of service, the provision of security and the objectives for energy efficiency. These needs and objectives influence the design of data centres in terms of building construction, power distribution, environmental control and physical security. Effective management and operational information is required to monitor achievement of the defined needs and objectives.

This series of European Standards specifies requirements and recommendations to support the various parties involved in the design, planning, procurement, integration, installation, operation and maintenance of facilities and infrastructures within data centres. These parties include:

- 1) owners, facility managers, ICT managers, project managers, main contractors;
- 2) architects, building designers and builders, system and installation designers;
- 3) facility and infrastructure integrators, suppliers of equipment;
- 4) installers, maintainers.

At the time of publication of this European Standard, EN 50600 series will comprise the following standards:

EN 50600-1, *Information technology - Data centre facilities and infrastructures - Part 1: General concepts*

EN 50600-2-1, *Information technology - Data centre facilities and infrastructures - Part 2-1: Building construction*

EN 50600-2-2, *Information technology - Data centre facilities and infrastructures - Part 2-2: Power distribution*

EN 50600-2-3, *Information technology - Data centre facilities and infrastructures - Part 2-3: Environmental control*

EN 50600-2-4, *Information technology - Data centre facilities and infrastructures - Part 2-4: Telecommunications cabling infrastructure*

EN 50600-2-5, *Information technology - Data centre facilities and infrastructures - Part 2-5: Security systems*

EN 50600-3-1, *Information technology - Data centre facilities and infrastructures - Part 3-1: Management and operational information*

The inter-relationship of the standards within the EN 50600 series is shown in Figure 1.

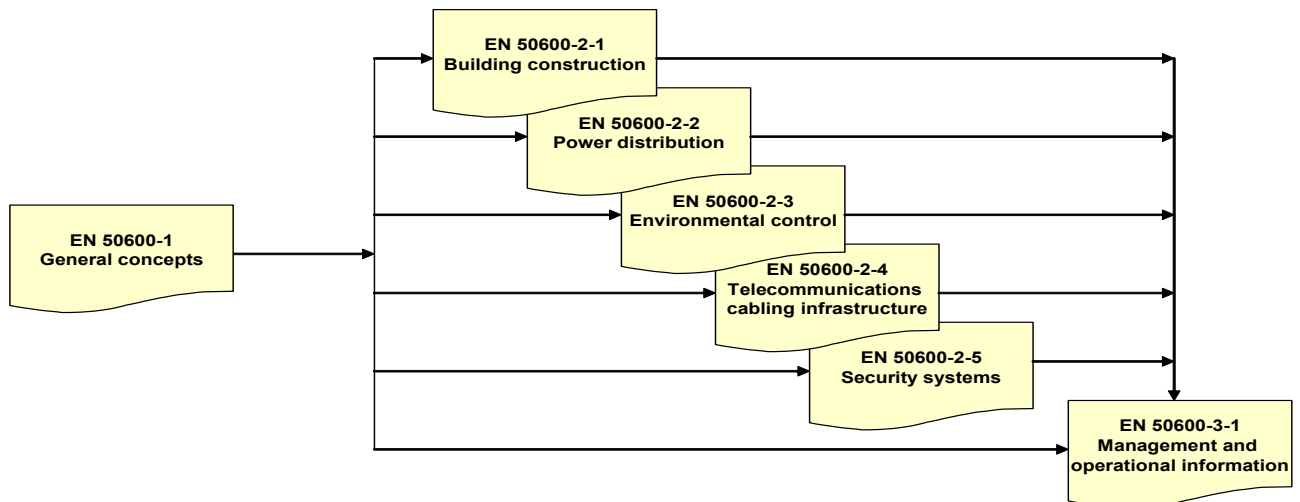

Figure 1 - Schematic relationship between the EN 50600 standards

EN 50600-2-X standards specify requirements and recommendations for particular facilities and infrastructures to support the relevant classification for “availability”, “security” and “energy efficiency enablement” selected from EN 50600-1.

EN 50600-3-X documents specify requirements and recommendations for data centre operations, processes and management.

This European Standard addresses the specific requirements for the telecommunications cabling infrastructure in data centres used for the purpose of IT networking and building services (in accordance with the requirements of EN 50600-1).

This European Standard is intended for use by and collaboration between architects, building designers and builders, system and installation designers.

This series of European Standards does not address the selection of information technology and network telecommunications equipment, software and associated configuration issues.

1 Scope

This European Standard addresses the wide range of telecommunications cabling infrastructures within data centres based upon the criteria and classifications for “availability” within EN 50600-1.

This European Standard specifies requirements and recommendations for the following:

- a) information technology and network telecommunications cabling (e.g. SAN and LAN);
- b) general information technology cabling to support the operation of the data centre;
- c) telecommunications cabling to monitor and control, as appropriate, power distribution, environmental control and physical security of the data centre;
- d) other building automation cabling;
- e) pathways, spaces and enclosures for the telecommunications cabling infrastructures.

Safety and electromagnetic compatibility (EMC) requirements are outside the scope of this European Standard and are covered by other standards and regulations. However, information given in this European Standard may be of assistance in meeting these standards and regulations.

2 Normative references

The following documents, in whole or in part, are normatively referenced in this document and are indispensable for its application. For dated references, only the edition cited applies. For undated references, the latest edition of the referenced document (including any amendments) applies.

EN 50173-1, *Information technology - Generic cabling systems - Part 1: General requirements*

EN 50173-2, *Information technology - Generic cabling systems - Part 2: Office premises*

EN 50173-5, *Information technology - Generic cabling systems - Part 5: Data centres*

EN 50173-6, *Information technology - Generic cabling systems – Part 6: Distributed building services*

EN 50174-1, *Information technology - Cabling installation - Part 1: Installation specification and quality assurance*

EN 50174-2, *Information technology - Cabling installation - Part 2 Installation planning and practices inside buildings*

EN 50600-1:2012, *Information technology - Data centre facilities and infrastructures - Part 1: General concepts*

EN 50600-2-1, *Information technology - Data centre facilities and infrastructures – Part 2-1: Building construction*

EN 50600-2-3, *Information technology - Data centre facilities and infrastructures - Part 2-3: Environmental control*

EN 50600-3-1¹⁾, *Information technology - Data centre facilities and infrastructures - Part 3-1: Management and operational information*

koniec náhľadu – text ďalej pokračuje v platenej verzii STN

1) Submitted to formal vote.