

STN	Potravinárske stroje. Mlynčeky na mäso. Bezpečnostné a hygienické požiadavky.	STN EN 12331 51 3055
------------	--	--

Food processing machinery - Mincing machines - Safety and hygiene requirements

Táto norma obsahuje anglickú verziu európskej normy.
This standard includes the English version of the European Standard.

Táto norma bola oznámená vo Vestníku ÚNMS SR č. 01/16

Obsahuje: EN 12331:2015

Oznámením tejto normy sa ruší
STN EN 12331+A2 (51 3055) z decembra 2010

122275

Úrad pre normalizáciu, metrológiu a skúšobníctvo SR, 2016
Podľa zákona č. 264/1999 Z. z. v znení neskorších predpisov sa môžu slovenské technické normy
rozmnožovať a rozširovať iba so súhlasom Úradu pre normalizáciu, metrológiu a skúšobníctvo SR.

EUROPEAN STANDARD

EN 12331

NORME EUROPÉENNE

EUROPÄISCHE NORM

September 2015

ICS 67.260

Supersedes EN 12331:2003+A2:2010

English Version

Food processing machinery - Mincing machines - Safety and hygiene requirements

Machines pour les produits alimentaires - Hachoirs -
Prescriptions relatives à la sécurité et à l'hygiène

Nahrungsmittelmaschinen - Wölfe - Sicherheits- und
Hygieneanforderungen

This European Standard was approved by CEN on 1 August 2015.

CEN members are bound to comply with the CEN/CENELEC Internal Regulations which stipulate the conditions for giving this European Standard the status of a national standard without any alteration. Up-to-date lists and bibliographical references concerning such national standards may be obtained on application to the CEN-CENELEC Management Centre or to any CEN member.

This European Standard exists in three official versions (English, French, German). A version in any other language made by translation under the responsibility of a CEN member into its own language and notified to the CEN-CENELEC Management Centre has the same status as the official versions.

CEN members are the national standards bodies of Austria, Belgium, Bulgaria, Croatia, Cyprus, Czech Republic, Denmark, Estonia, Finland, Former Yugoslav Republic of Macedonia, France, Germany, Greece, Hungary, Iceland, Ireland, Italy, Latvia, Lithuania, Luxembourg, Malta, Netherlands, Norway, Poland, Portugal, Romania, Slovakia, Slovenia, Spain, Sweden, Switzerland, Turkey and United Kingdom.



EUROPEAN COMMITTEE FOR STANDARDIZATION
COMITÉ EUROPÉEN DE NORMALISATION
EUROPÄISCHES KOMITEE FÜR NORMUNG

CEN-CENELEC Management Centre: Avenue Marnix 17, B-1000 Brussels

Contents	Page
European foreword.....	4
Introduction	5
1 Scope.....	6
2 Normative references.....	8
3 Terms and definitions	9
4 List of hazards	11
5 Safety requirements and/or measures	14
5.1 General.....	14
5.2 Mechanical safety.....	14
5.2.1 General.....	14
5.2.2 Zone 1 – Measures at mincing machines with feed intake and worm.....	14
5.2.3 Zone 2 – Measures at mincing machines with feed intake hopper and screw conveyor....	16
5.2.4 Zone 3 – Discharge outlet on mincing machines.....	20
5.2.5 Zone 4 – Removal of worm and set of cutting tools.....	21
5.2.6 Zone 5 – Drive system.....	21
5.2.7 Zone 6 – Machine components e.g. cover over hopper edge	22
5.2.8 Zone 7 to 10 – Mincing machines with loading devices.....	22
5.3 Electrical hazards.....	24
5.3.1 General.....	24
5.3.2 Stopping function of switching devices.....	24
5.3.3 Emergency stop-device	24
5.3.4 Protection against water ingress.....	24
5.3.5 ON- and OFF-switch	25
5.3.6 Safety requirements related to electromagnetic phenomena.....	25
5.4 Hazards from loss of stability	26
5.5 Noise reduction.....	26
5.6 Hazards from use of gases (N ₂ , CO ₂ and steam).....	26
5.7 Ergonomic requirements	26
5.8 Hygiene and cleaning.....	27
5.8.1 General.....	27
5.8.2 Food area.....	28
5.8.3 Splash area.....	29
5.8.4 Non-food area	29
5.8.5 Surface conditions	29
5.8.6 Cleaning.....	29
6 Verification of safety requirements and/or measures.....	29
7 Information for use	31
7.1 General.....	31
7.2 Operating instruction	31
7.3 Marking.....	33
Annex A (normative) Noise test code for mincing machines (grade 2)	34
A.1 Emission sound pressure level determination	34

A.2	Installation and mounting conditions.....	34
A.3	Operating conditions.....	34
A.4	Measurement	34
A.5	Information to be recorded	34
A.6	Information to be reported.....	34
A.7	Declaration and verification of the noise emission values.....	35
	Annex B (normative) Design principles to ensure cleanability of mincing machines.....	36
B.1	Definition.....	36
B.2	Materials	36
B.2.1	General	36
B.2.2	Type of materials	37
B.3	Design	37
B.3.1	General	37
B.3.2	Food area	37
B.3.3	Splash area	38
B.3.4	Non-food area.....	40
	Annex ZA (informative) Relationship between this European Standard and the Essential Requirements of EU Directive 2006/42/EC.....	41
	Bibliography	42

European foreword

This document (EN 12331:2015) has been prepared by Technical Committee CEN/TC 153 “Machinery intended for use with foodstuffs and feed”, the secretariat of which is held by DIN.

This European Standard shall be given the status of a national standard, either by publication of an identical text or by endorsement, at the latest by March 2016, and conflicting national standards shall be withdrawn at the latest by March 2016.

Attention is drawn to the possibility that some of the elements of this document may be the subject of patent rights. CEN [and/or CENELEC] shall not be held responsible for identifying any or all such patent rights.

This document supersedes EN 12331:2003+A2:2010.

This document has been prepared under a mandate given to CEN by the European Commission and the European Free Trade Association, and supports essential requirements of EU Directive 2006/42/EC.

For relationship with EU Directive 2006/42/EC, see informative Annex ZA, which is an integral part of this document.

Significant changes

The significant changes with respect to the previous edition EN 12331:2003+A2:2010 are listed below:

- same pictures have been renewed and renumbered;
- Clause 2: EN 1088 replaced by EN ISO 14119;
- Clause 3: clarify of some definitions and use of this wording in the document;
- Clause 4: transferred to a table;
- 5.2.5.1: inclusion of a note that under certain conditions the combination of specific hole plates diameter with specific hole diameter represents a securing element;
- Bibliography: with respect to 5.2.4.2 the standards DIN 9810 and UNI 11303 were added.

According to the CEN-CENELEC Internal Regulations, the national standards organizations of the following countries are bound to implement this European Standard: Austria, Belgium, Bulgaria, Croatia, Cyprus, Czech Republic, Denmark, Estonia, Finland, Former Yugoslav Republic of Macedonia, France, Germany, Greece, Hungary, Iceland, Ireland, Italy, Latvia, Lithuania, Luxembourg, Malta, Netherlands, Norway, Poland, Portugal, Romania, Slovakia, Slovenia, Spain, Sweden, Switzerland, Turkey and the United Kingdom.

Introduction

This document is a type-C-standard as stated in EN ISO 12100.

The machinery concerned and the extent to which hazards, hazardous situations and hazardous events are covered are indicated in the scope of this document.

When provisions of this type-C-standard are different from those which are stated in type-A- or -B-standards, the provisions of this type-C-standard take precedence over the provisions of the other standards, for machines that have been designed and built according to the provisions of this type-C-standard.

1 Scope

1.1 This European Standard specifies requirements for the design and manufacture of mincing machines (see Figures 1a and 1b) used in a stationary position.

The machines covered by this European Standard are used for size reduction of fresh or frozen meat, meat products and fish (hereinafter referred to as product) by cutting in a set of cutting tools.

Mincing machines for domestic uses are not included in this European Standard. Filling mincers are covered by EN 12463 "Food processing machinery – Filling machines and auxiliary machines – Safety and hygiene requirements".

This European Standard applies only to machines that are manufactured after the date of issue of this European Standard.

Mincing machines in connection with using a hold-to-run foot switch are not covered by this European Standard.

This European Standard covers:

- mincing machines used in shops and preparation rooms;
- mincing machines used in kitchens where sausages are prepared;
- mincing machines used industrially;
- accessories.

The extent to which hazards are covered, is indicated in this European Standard. For other hazards which are not covered by this European Standard, machinery should comply with EN ISO 12100:2010 where applicable.

This European Standard is not dealing with specific requirements for the control of mincing machines with foot switch.

1.2 This European Standard covers the following types:

- mincing machine with feed tray, feed intake and pusher, diameter ≤ 52 mm on feed intake (see Figure 3);
- mincing machine with feed tray, feed intake, restrictor plate and pusher, diameter > 52 mm on feed intake (see Figure 4);
- mincing machine with feed intake hopper and cover, screw conveyor, with ¹⁾ or without mixing screw in feed intake hopper (see Figure 5);
- mincing machine with feed intake hopper, with or without cover, screw conveyor, with ¹⁾ or without mixing screw in the feed intake hopper, with loading device (continuously or discontinuously).

Mincing machines comprise a machine base, a worm casing with a worm, a feed tray (with feed intake) or a feed intake hopper, a screw conveyor (and sometimes an additional mixing screw in the feed intake hopper), a set of cutting tools, a lock nut, a loading device, a drive motor and – depending on machine type – electrical, hydraulic and pneumatic components. They will also have various safeguarding devices as examples in Clause 5.

1) In this case, EN 13570 should be taken into consideration.

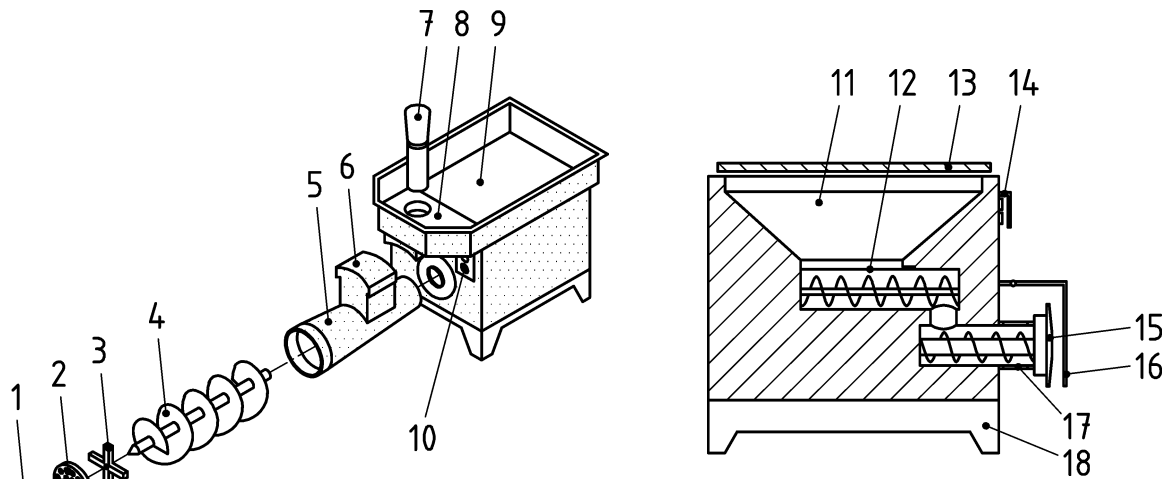

a) Mincing machine with feed tray and restrictor plate

b) Mincing machine with feed intake hopper, cover and screw conveyor

Key

1	lock nut	6	feed intake	11	feed intake hopper	15	lock nut
2	hole plate	7	pusher	12	screw conveyor	16	protective hood
3	blade	8	restrictor plate	13	cover	17	worm
4	worm	9	feed tray	14	on-/off-switch with protective hood	18	machine rack
5	worm casing	10	on-/off-switch				

Figure 1 — Arrangement of a mincing machine

Mincing machines may be equipped e.g. with

- an extraction claw,
- an ejector or extractor,
- a protective hood over the discharge outlet,
- a cover over the inlet opening of the feed intake hopper,
- a transport carriage for the lock nut, the set of cutting tools, the worm and the screw conveyor,
- a lifting device for the lock nut, the set of cutting tools, the worm and the screw conveyor,
- a loading device.

1.3 Intended use

The product is fed manually or by means of the loading device into the mincing machine. The product is fed to the worm either by means of a pusher or a screw conveyor and size reduced in the set of cutting tools.

It is not intended that mincing machines are cleaned with pressurized water. However, it is to be foreseen that it is difficult to guarantee that this method will never be used in practice. In order to deal with this eventuality, the requirements of 5.3.4 should apply.

This European Standard specifies all significant hazards, hazardous situations and events relevant to mincing machines, when they are used as intended and under conditions of misuse which are reasonably foreseeable by the manufacturer (see Clause 4).

This European Standard specifies the hazards which can arise during commissioning, operation, cleaning, use, maintenance and decommissioning of the machine.

2 Normative references

The following documents, in whole or in part, are normatively referenced in this document and are indispensable for its application. For dated references, only the edition cited applies. For undated references, the latest edition of the referenced document (including any amendments) applies.

EN 349, *Safety of machinery — Minimum gaps to avoid crushing of parts of the human body*

EN 614-1, *Safety of machinery — Ergonomic design principles — Part 1: Terminology and general principles*

EN 953:1997+A1:2009, *Safety of machinery — Guards — General requirements for the design and construction of fixed and movable guards*

EN 1005-1, *Safety of machinery — Human physical performance — Part 1: Terms and definitions*

EN 1005-2, *Safety of machinery — Human physical performance — Part 2: Manual handling of machinery and component parts of machinery*

EN 1005-3, *Safety of machinery — Human physical performance — Part 3: Recommended force limits for machinery operation*

EN 1672-2:2005+A1:2009, *Food processing machinery — Basic concepts — Part 2: Hygiene requirements*

EN 60204-1:2006, *Safety of machinery — Electrical equipment of machines — Part 1: General requirements (IEC 60204-1:2005, modified)*

EN 60529, *Degrees of protection provided by enclosures (IP Code) (IEC 60529)*

EN 61496-1, *Safety of machinery — Electro-sensitive protective equipment — Part 1: General requirements and tests (IEC 61496-1)*

EN ISO 4287, *Geometrical product specifications (GPS) — Surface texture: Profile method — Terms, definitions and surface texture parameters (ISO 4287)*

EN ISO 4871, *Acoustics — Declaration and verification of noise emission values of machinery and equipment (ISO 4871)*

EN ISO 11204:2010, *Acoustics — Noise emitted by machinery and equipment — Determination of emission sound pressure levels at a work station and at other specified positions applying accurate environmental corrections (ISO 11204:2010)*

EN ISO 11688-1, *Acoustics — Recommended practice for the design of low-noise machinery and equipment — Part 1: Planning (ISO/TR 11688-1)*

EN ISO 12100:2010, *Safety of machinery — General principles for design — Risk assessment and risk reduction (ISO 12100:2010)*

EN ISO 13849-1:2008, *Safety of machinery — Safety-related parts of control systems — Part 1: General principles for design (ISO 13849-1:2006)*

EN ISO 13857:2008, *Safety of machinery — Safety distances to prevent hazard zones being reached by upper and lower limbs (ISO 13857:2008)*

EN ISO 14119:2013, *Safety of machinery — Interlocking devices associated with guards — Principles for design and selection (ISO 14119:2013)*

koniec náhľadu – text ďalej pokračuje v platenej verzii STN