

<b>STN</b>	<b>Potravinárske stroje. Stroje na rezanie rezňov. Bezpečnostné a hygienické požiadavky.</b>	<b>STN EN 13870</b>  51 3075
------------	--	--

Food processing machinery - Portion cutting machines - Safety and hygiene requirements

Táto norma obsahuje anglickú verziu európskej normy.  
This standard includes the English version of the European Standard.

Táto norma bola oznámená vo Vestníku ÚNMS SR č. 01/16

Obsahuje: EN 13870:2015

Oznámením tejto normy sa ruší  
STN EN 13870+A1 (51 3075) z decembra 2010

**122276**

EUROPEAN STANDARD

**EN 13870**

NORME EUROPÉENNE

EUROPÄISCHE NORM

September 2015

ICS 67.260

Supersedes EN 13870:2005+A1:2010

English Version

## Food processing machinery - Portion cutting machines - Safety and hygiene requirements

Machines pour les produits alimentaires -  
Portionneuses - Prescriptions relatives à la sécurité et  
à l'hygiène

Nahrungsmittelmaschinen -  
Portionsschneidemaschinen - Sicherheits- und  
Hygieneanforderungen

This European Standard was approved by CEN on 1 August 2015.

CEN members are bound to comply with the CEN/CENELEC Internal Regulations which stipulate the conditions for giving this European Standard the status of a national standard without any alteration. Up-to-date lists and bibliographical references concerning such national standards may be obtained on application to the CEN-CENELEC Management Centre or to any CEN member.

This European Standard exists in three official versions (English, French, German). A version in any other language made by translation under the responsibility of a CEN member into its own language and notified to the CEN-CENELEC Management Centre has the same status as the official versions.

CEN members are the national standards bodies of Austria, Belgium, Bulgaria, Croatia, Cyprus, Czech Republic, Denmark, Estonia, Finland, Former Yugoslav Republic of Macedonia, France, Germany, Greece, Hungary, Iceland, Ireland, Italy, Latvia, Lithuania, Luxembourg, Malta, Netherlands, Norway, Poland, Portugal, Romania, Slovakia, Slovenia, Spain, Sweden, Switzerland, Turkey and United Kingdom.



EUROPEAN COMMITTEE FOR STANDARDIZATION  
COMITÉ EUROPÉEN DE NORMALISATION  
EUROPÄISCHES KOMITEE FÜR NORMUNG

**CEN-CENELEC Management Centre: Avenue Marnix 17, B-1000 Brussels**

<b>Contents</b>	<b>Page</b>
European foreword.....	4
Introduction .....	5
<b>1 Scope .....</b>	<b>6</b>
1.1 General.....	6
1.2 Types of machinery .....	6
1.3 Machine construction .....	8
1.4 Intended use .....	8
<b>2 Normative references.....</b>	<b>9</b>
<b>3 Terms and definitions .....</b>	<b>10</b>
<b>4 List of significant hazards .....</b>	<b>12</b>
<b>5 Safety and hygiene requirements and/or protective measures .....</b>	<b>16</b>
5.1 General.....	16
5.2 Mechanical hazards.....	16
5.2.1 General.....	16
5.2.2 Zone 1 – Powered components in the feed zone.....	17
5.2.3 Zone 2 – Powered components in the discharge zone.....	20
5.2.4 Zone 3 – Movable guards.....	21
5.2.5 Zone 4 – Blade protection.....	22
5.2.6 Zone 5 – Blade mounting.....	24
5.2.7 Zone 6 – Locking slide / Hold-down unit.....	24
5.2.8 Zone 7 – Grippers .....	24
5.2.9 Zone 8 – Transport conveyor belts .....	24
5.2.10 Sorting stations.....	25
5.2.11 Drive components in the machine housing .....	26
5.2.12 Interlocks of guards for preventing access to the moving blade .....	26
5.3 Electrical hazards.....	27
5.3.1 General.....	27
5.3.2 Emergency stop.....	27
5.3.3 Protection against water ingress.....	28
5.4 Hydraulic and pneumatic hazards.....	29
5.5 Hazard from loss of stability .....	29
5.6 Noise reduction.....	29
5.7 Ergonomic requirements .....	29
5.8 Hygiene and cleaning.....	30
5.8.1 General.....	30
5.8.2 Food area.....	31
5.8.3 Splash area.....	32
5.8.4 Non-food area .....	32
5.8.5 Surface condition .....	32
5.8.6 Cleaning.....	32
<b>6 Verification of safety and hygiene requirements and/or protective measures.....</b>	<b>33</b>
<b>7 Information for use .....</b>	<b>34</b>
7.1 General.....	34
7.2 Instruction handbook.....	34

<b>7.3 Marking .....</b>	<b>37</b>
<b>Annex A (normative) Noise test code for portion cutting machines (grade 2) .....</b>	<b>38</b>
<b>Annex B (normative) Design principles to ensure cleanability of portion cutting machines and their auxiliary components .....</b>	<b>40</b>
<b>Annex ZA (informative) Relationship between this European Standard and the Essential Requirements of EU Directive 2006/42/EC.....</b>	<b>45</b>
<b>Bibliography .....</b>	<b>46</b>

## European foreword

This document (EN 13870:2015) has been prepared by Technical Committee CEN/TC 153 "Machinery intended for use with foodstuffs and feed", the secretariat of which is held by DIN.

This European Standard shall be given the status of a national standard, either by publication of an identical text or by endorsement, at the latest by March 2016, and conflicting national standards shall be withdrawn at the latest by March 2016.

Attention is drawn to the possibility that some of the elements of this document may be the subject of patent rights. CEN [and/or CENELEC] shall not be held responsible for identifying any or all such patent rights.

This document supersedes EN 13870:2005+A1:2010.

This document has been prepared under a mandate given to CEN by the European Commission and the European Free Trade Association, and supports essential requirements of EU Directive 2006/42/EC.

For relationship with EU Directive 2006/42/EC, see informative Annex ZA, which is an integral part of this document.

### Significant changes

The significant changes with respect to the previous edition EN 13870:2005+A1:2010 are listed below:

- Clause 1: types of machines have been adapted to the current state of the art; pictures of the types of machines have been renewed; exclusion of automatic industrial slicing machines;
- Clause 3: clarify of some definitions and use of this wording in the document;
- Clause 4: transferred to a table;
- inclusion of automatic loading;
- better description of the requirements for protective equipment;
- better description of risk areas, such as inlet tunnel (including dimension table);
- new components have been added, such as pusher and rocker.

According to the CEN-CENELEC Internal Regulations, the national standards organizations of the following countries are bound to implement this European Standard: Austria, Belgium, Bulgaria, Croatia, Cyprus, Czech Republic, Denmark, Estonia, Finland, Former Yugoslav Republic of Macedonia, France, Germany, Greece, Hungary, Iceland, Ireland, Italy, Latvia, Lithuania, Luxembourg, Malta, Netherlands, Norway, Poland, Portugal, Romania, Slovakia, Slovenia, Spain, Sweden, Switzerland, Turkey and the United Kingdom.

## **Introduction**

This document is a type-C-standard as stated in EN ISO 12100.

The machinery concerned and the extent to which hazards, hazardous situations and events are covered are indicated in the scope of this document.

When provisions of this type-C-standard are different from those which are stated in type-A- or -B-standards, the provisions of this type-C-standard take precedence over the provisions of the other standards, for machines that have been designed and built according to the provisions of this type-C-standard.

# 1 Scope

## 1.1 General

This European Standard covers portion cutting machines and accessories.

This European Standard does not apply to automatic industrial slicing machines (see prEN 16743) and band saw machines (see EN 12268).

This European Standard defines requirements for the design and manufacture of portion cutting machines.

The machines covered by this European Standard are used for continuous portioning of fresh, smoked or frozen meat with and without bones or of similar products by separation by means of a blade.

This European Standard deals with all significant hazards, hazardous situations and events relevant to machines, appliances and machinery, when they are used as intended and under conditions of misuse which are reasonably foreseeable by the manufacturer (see Clause 4).

This European Standard deals with the hazards which can arise during commissioning, operation, maintenance and decommissioning of the machine.

The European Standard does not deal with the specific hazards of loading devices.

This European Standard is not applicable to portion cutting machines which are manufactured before the date of publication of this document by CEN.

## 1.2 Types of machinery

This European Standard covers the following types of machinery:

- portion cutting machines with manual loading (see Figure 1);
- portion cutting machines with automatic loading (see Figure 2).

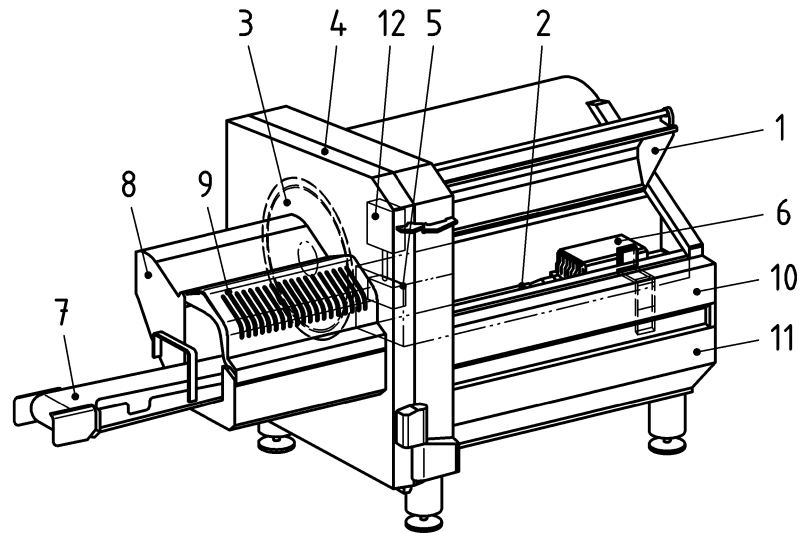
**Key**

- |   |  |    |  |
|---|--|----|--|
| 1 | loading protection hood                  | 7  | discharge conveyor belt (optional)                       |
| 2 | product base                             | 8  | discharge chute  |
| 3 | round/sickle blade                       | 9  | discharge chute hood                                     |
| 4 | blade protection hood/cutting space      | 10 | feed protection hood                                     |
| 5 | cutting zone                             | 11 | machine housing  |
| 6 | cutting material holder/feeding carriage | 12 | locking slide/hold-down unit (depending on machine type) |

**Figure 1 — Portion cutting machine with manual loading (exemplary embodiment)**

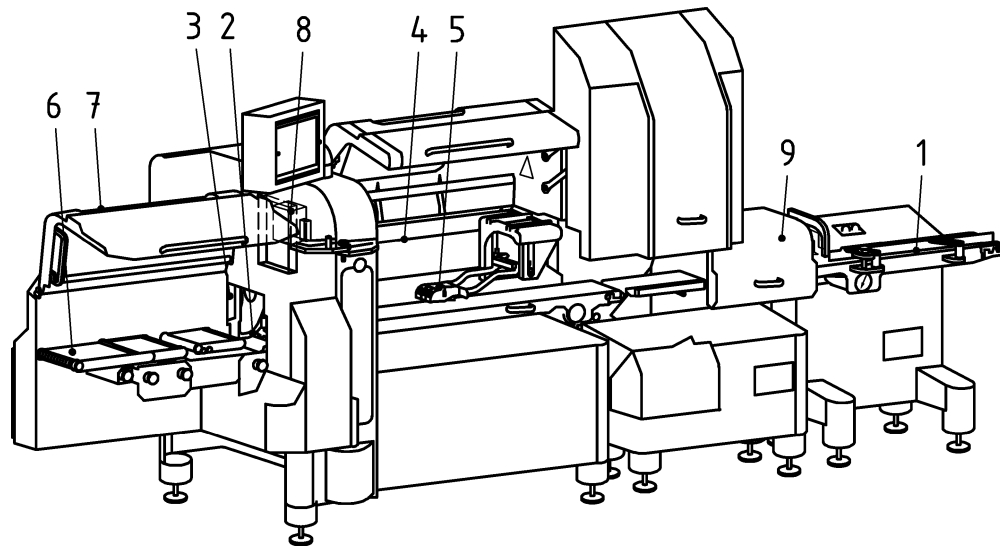

**Key**

1	product base	6	discharge conveyor belt
2	blade	7	discharge chute hood
3	blade protection hood/cutting space	8	hold-down unit
4	machine housing	9	pre-weighing unit (optional)
5	cutting material holder/feeding carriage		

**Figure 2 — Portion cutting machine with automatic loading (exemplary embodiment)**

### 1.3 Machine construction

Portion cutting machines depending on the construction consist of: machine housing (machine frame), fixed or moving product bases, automatic or manually operated grippers, hold-down unit, blade housing, blade, discharge device, associated drives, electrical, hydraulic or pneumatic components.

Portion cutting machines in the scope of this document may be equipped with the following auxiliary components:

- loading aid;
- discharge conveyor belt;
- laying unit;
- measurement or scanning devices;
- scales;
- sorting station (e.g. rocker, pusher);
- movement devices (e.g. castors).

### 1.4 Intended use

The intended use (as defined in EN ISO 12100:2010, 3.23) of portion cutting machines as dealt with in this document is described in 1.1.

The product is manually placed on the product base or automatically fed to the product base with a loading device. The product is supplied to the blade by automatic or manually operated grippers or conveyor slide or belt and the cutting process begins. The portion falls onto a discharge conveyor or a laying unit.

## 2 Normative references

The following documents, in whole or in part, are normatively referenced in this document and are indispensable for its application. For dated references, only the edition cited applies. For undated references, the latest edition of the referenced document (including any amendments) applies.

EN 614-1, *Safety of machinery — Ergonomic principles for design — Part 1: Terminology and general principles*

EN 953:1997+A1:2009, *Safety of machinery — Guards — General requirements for the design and construction of fixed and movable guards*

EN 1005-1, *Safety of machinery — Human physical performance — Part 1: Terms and definitions*

EN 1005-2, *Safety of machinery — Human physical performance — Part 2: Manual handling of machinery and component parts of machinery*

EN 1005-3, *Safety of machinery — Human physical performance — Part 3: Recommended force limits for machinery operation*

EN 1672-2, *Food processing machinery — Basic concepts — Part 2: Hygiene requirements*

EN 60204-1:2006, *Safety of machinery — Electrical equipment of machines — Part 1: General requirements (IEC 60204-1:2005, modified)*

EN 60529, *Degrees of protection provided by enclosures (IP Code) (IEC 60529)*

EN ISO 3744:2010, *Acoustics — Determination of sound power levels and sound energy levels of noise sources using sound pressure — Engineering methods for an essentially free field over a reflecting plane (ISO 3744:2010)*

EN ISO 4413, *Hydraulic fluid power — General rules and safety requirements for systems and their components (ISO 4413)*

EN ISO 4414, *Pneumatic fluid power — General rules and safety requirements for systems and their components (ISO 4414)*

EN ISO 4871, *Acoustics — Declaration and verification of noise emission values of machinery and equipment (ISO 4871)*

EN ISO 11201:2010, *Acoustics - Noise emitted by machinery and equipment — Determination of emission sound pressure levels at a work station and at other specified positions in an essentially free field over a reflecting plane with negligible environmental corrections (ISO 11201:2010)*

EN ISO 11688-1, *Acoustics — Recommended practice for the design of low-noise machinery and equipment — Part 1: Planning (ISO/TR 11688-1)*

EN ISO 12100:2010, *Safety of machinery — General principles for design — Risk assessment and risk reduction (ISO 12100:2010)*

**EN 13870:2015 (E)**

EN ISO 13849-1, *Safety of machinery — Safety-related parts of control systems —Part 1: General principles for design (ISO 13849-1)*

EN ISO 13855, *Safety of machinery — Positioning of safeguards with respect to the approach speeds of parts of the human body (ISO 13855)*

EN ISO 13857:2008, *Safety of machinery — Safety distances to prevent hazard zones being reached by upper and lower limbs (ISO 13857:2008)*

EN ISO 14119:2013, *Safety of machinery — Interlocking devices associated with guards — Principles for design and selection (ISO 14119:2013)*

**koniec náhľadu – text ďalej pokračuje v platenej verzii STN**