

STN	Konektory pre elektronické zariadenia. Časť 7-81: Podrobná špecifikácia pre 8-pólové tienené voľné i pevné konektory na dátové prenosy na frekvenciách do 2 000 MHz.	STN EN 60603-7-81
		35 4620

Connectors for electronic equipment - Part 7-81: Detail specification for 8-way, shielded, free and fixed connectors, for data transmissions with frequencies up to 2 000 MHz

Táto norma obsahuje anglickú verziu európskej normy.
This standard includes the English version of the European Standard.

Táto norma bola oznámená vo Vestníku ÚNMS SR č. 09/16

Obsahuje: EN 60603-7-81:2016, IEC 60603-7-81:2015

123436

EUROPEAN STANDARD

EN 60603-7-81

NORME EUROPÉENNE

EUROPÄISCHE NORM

April 2016

ICS 31.220.10

English Version

Connectors for electronic equipment -
Part 7-81: Detail specification for 8-way, shielded, free and fixed
connectors, for data transmissions with frequencies
up to 2 000 MHz
(IEC 60603-7-81:2015)

Connecteurs pour équipements électroniques -
Partie 7-81: Spécification particulière pour les fiches et les
embases blindées à 8 voies pour la transmission de
données à des fréquences jusqu'à 2 000 MHz
(IEC 60603-7-81:2015)

Steckverbinder für elektronische Einrichtungen -
Teil 7-81: Bauartspezifikation für geschirmte freie und feste
Steckverbinder, 8polig, für Datenübertragungen bis 2 000
MHz
(IEC 60603-7-81:2015)

This European Standard was approved by CENELEC on 2016-01-20. CENELEC members are bound to comply with the CEN/CENELEC Internal Regulations which stipulate the conditions for giving this European Standard the status of a national standard without any alteration.

Up-to-date lists and bibliographical references concerning such national standards may be obtained on application to the CEN-CENELEC Management Centre or to any CENELEC member.

This European Standard exists in three official versions (English, French, German). A version in any other language made by translation under the responsibility of a CENELEC member into its own language and notified to the CEN-CENELEC Management Centre has the same status as the official versions.

CENELEC members are the national electrotechnical committees of Austria, Belgium, Bulgaria, Croatia, Cyprus, the Czech Republic, Denmark, Estonia, Finland, Former Yugoslav Republic of Macedonia, France, Germany, Greece, Hungary, Iceland, Ireland, Italy, Latvia, Lithuania, Luxembourg, Malta, the Netherlands, Norway, Poland, Portugal, Romania, Slovakia, Slovenia, Spain, Sweden, Switzerland, Turkey and the United Kingdom.



European Committee for Electrotechnical Standardization
Comité Européen de Normalisation Electrotechnique
Europäisches Komitee für Elektrotechnische Normung

CEN-CENELEC Management Centre: Avenue Marnix 17, B-1000 Brussels

European foreword

The text of document 48B/2451/FDIS, future edition 1 of IEC 60603-7-81, prepared by SC 48B "Electrical connectors" of IEC/TC 48 "Electrical connectors and mechanical structures for electrical and electronic equipment" was submitted to the IEC-CENELEC parallel vote and approved by CENELEC as EN 60603-7-81:2016.

The following dates are fixed:

- latest date by which the document has to be implemented at national level by publication of an identical national standard or by endorsement (dop) 2016-10-20
- latest date by which the national standards conflicting with the document have to be withdrawn (dow) 2019-01-20

Attention is drawn to the possibility that some of the elements of this document may be the subject of patent rights. CENELEC [and/or CEN] shall not be held responsible for identifying any or all such patent rights.

Endorsement notice

The text of the International Standard IEC 60603-7-81:2015 was approved by CENELEC as a European Standard without any modification.

In the official version, for Bibliography, the following notes have to be added for the standards indicated:

IEC 60603-7-2:2010	NOTE	Harmonized as EN 60603-7-2:2010 (not modified).
IEC 60603-7-3:2010	NOTE	Harmonized as EN 60603-7-3:2010 (not modified).
IEC 60603-7-4:2010	NOTE	Harmonized as EN 60603-7-4:2010 (not modified).
IEC 60603-7-41:2010	NOTE	Harmonized as EN 60603-7-41:2010 (not modified).
IEC 60603-7-51:2010	NOTE	Harmonized as EN 60603-7-51:2010 (not modified).
IEC 60603-7-7:2010	NOTE	Harmonized as EN 60603-7-7:2010 (not modified).
IEC 60603-71:2010	NOTE	Harmonized as EN 60603-71:2010 (not modified).

Annex ZA (normative)

Normative references to international publications with their corresponding European publications

The following documents, in whole or in part, are normatively referenced in this document and are indispensable for its application. For dated references, only the edition cited applies. For undated references, the latest edition of the referenced document (including any amendments) applies.

NOTE 1 When an International Publication has been modified by common modifications, indicated by (mod), the relevant EN/HD applies.

NOTE 2 Up-to-date information on the latest versions of the European Standards listed in this annex is available here: www.cenelec.eu

<u>Publication</u>	<u>Year</u>	<u>Title</u>	<u>EN/HD</u>	<u>Year</u>
IEC 60512-2-1	-	Connectors for electronic equipment - Tests and measurements - Part 2-1: Electrical continuity and contact resistance tests - Test 2a: Contact resistance - Millivolt level method	EN 60512-2-1	-
IEC 60512-25-9	-	Connectors for electronic equipment - Tests and measurements - Part 25-9: Signal integrity tests - Test 25i: Alien crosstalk	EN 60512-25-9	-
IEC 60512-26-100	-	Connectors for electronic equipment - Tests and measurements - Part 26-100: Measurement setup, test and reference arrangements and measurements for connectors according to IEC 60603-7 - Tests 26a to 26g	EN 60512-26-100	-
IEC 60512-28-100	-	Connectors for electronic equipment - Tests and measurements - Part 28-100: Signal integrity tests up to 1 000 MHz on IEC 60603-7 and IEC 61076-3 series connectors - Tests 28a to 28g	EN 60512-28-100	-
IEC 60603-7	2008	Connectors for electronic equipment - Part 7: Detail specification for 8-way, unshielded, free and fixed connectors	EN 60603-7	2009
IEC 60603-7-1	2011	Connectors for electronic equipment - Part 7-1: Detail specification for 8-way, shielded, free and fixed connectors	EN 60603-7-1	2011
IEC 61156	Series	Multicore and symmetrical pair/quad cables for digital communications	-	-
IEC 62153-4-15	2015	Metallic communication cable test methods - Part 4-15: Electromagnetic compatibility (EMC) - Test method for measuring transfer impedance and screening attenuation - or coupling attenuation with triaxial cell	-	-



INTERNATIONAL STANDARD

NORME INTERNATIONALE

**Connectors for electronic equipment –
Part 7-81: Detail specification for 8-way, shielded, free and fixed connectors, for
data transmissions with frequencies up to 2 000 MHz**

**Connecteurs pour équipements électroniques –
Partie 7-81: Spécification particulière pour les fiches et les embases blindées à
8 voies pour la transmission de données à des fréquences jusqu'à 2 000 MHz**





THIS PUBLICATION IS COPYRIGHT PROTECTED
Copyright © 2015 IEC, Geneva, Switzerland

All rights reserved. Unless otherwise specified, no part of this publication may be reproduced or utilized in any form or by any means, electronic or mechanical, including photocopying and microfilm, without permission in writing from either IEC or IEC's member National Committee in the country of the requester. If you have any questions about IEC copyright or have an enquiry about obtaining additional rights to this publication, please contact the address below or your local IEC member National Committee for further information.

Droits de reproduction réservés. Sauf indication contraire, aucune partie de cette publication ne peut être reproduite ni utilisée sous quelque forme que ce soit et par aucun procédé, électronique ou mécanique, y compris la photocopie et les microfilms, sans l'accord écrit de l'IEC ou du Comité national de l'IEC du pays du demandeur. Si vous avez des questions sur le copyright de l'IEC ou si vous désirez obtenir des droits supplémentaires sur cette publication, utilisez les coordonnées ci-après ou contactez le Comité national de l'IEC de votre pays de résidence.

IEC Central Office
 3, rue de Varembe
 CH-1211 Geneva 20
 Switzerland

Tel.: +41 22 919 02 11
 Fax: +41 22 919 03 00
info@iec.ch
www.iec.ch

About the IEC

The International Electrotechnical Commission (IEC) is the leading global organization that prepares and publishes International Standards for all electrical, electronic and related technologies.

About IEC publications

The technical content of IEC publications is kept under constant review by the IEC. Please make sure that you have the latest edition, a corrigenda or an amendment might have been published.

IEC Catalogue - webstore.iec.ch/catalogue

The stand-alone application for consulting the entire bibliographical information on IEC International Standards, Technical Specifications, Technical Reports and other documents. Available for PC, Mac OS, Android Tablets and iPad.

IEC publications search - www.iec.ch/searchpub

The advanced search enables to find IEC publications by a variety of criteria (reference number, text, technical committee,...). It also gives information on projects, replaced and withdrawn publications.

IEC Just Published - webstore.iec.ch/justpublished

Stay up to date on all new IEC publications. Just Published details all new publications released. Available online and also once a month by email.

Electropedia - www.electropedia.org

The world's leading online dictionary of electronic and electrical terms containing more than 30 000 terms and definitions in English and French, with equivalent terms in 15 additional languages. Also known as the International Electrotechnical Vocabulary (IEV) online.

IEC Glossary - std.iec.ch/glossary

More than 60 000 electrotechnical terminology entries in English and French extracted from the Terms and Definitions clause of IEC publications issued since 2002. Some entries have been collected from earlier publications of IEC TC 37, 77, 86 and CISPR.

IEC Customer Service Centre - webstore.iec.ch/csc

If you wish to give us your feedback on this publication or need further assistance, please contact the Customer Service Centre: csc@iec.ch.

A propos de l'IEC

La Commission Electrotechnique Internationale (IEC) est la première organisation mondiale qui élabore et publie des Normes internationales pour tout ce qui a trait à l'électricité, à l'électronique et aux technologies apparentées.

A propos des publications IEC

Le contenu technique des publications IEC est constamment revu. Veuillez vous assurer que vous possédez l'édition la plus récente, un corrigendum ou amendement peut avoir été publié.

Catalogue IEC - webstore.iec.ch/catalogue

Application autonome pour consulter tous les renseignements bibliographiques sur les Normes internationales, Spécifications techniques, Rapports techniques et autres documents de l'IEC. Disponible pour PC, Mac OS, tablettes Android et iPad.

Recherche de publications IEC - www.iec.ch/searchpub

La recherche avancée permet de trouver des publications IEC en utilisant différents critères (numéro de référence, texte, comité d'études,...). Elle donne aussi des informations sur les projets et les publications remplacées ou retirées.

IEC Just Published - webstore.iec.ch/justpublished

Restez informé sur les nouvelles publications IEC. Just Published détaille les nouvelles publications parues. Disponible en ligne et aussi une fois par mois par email.

Electropedia - www.electropedia.org

Le premier dictionnaire en ligne de termes électroniques et électriques. Il contient plus de 30 000 termes et définitions en anglais et en français, ainsi que les termes équivalents dans 15 langues additionnelles. Egalement appelé Vocabulaire Electrotechnique International (IEV) en ligne.

Glossaire IEC - std.iec.ch/glossary

Plus de 60 000 entrées terminologiques électrotechniques, en anglais et en français, extraites des articles Termes et Définitions des publications IEC parues depuis 2002. Plus certaines entrées antérieures extraites des publications des CE 37, 77, 86 et CISPR de l'IEC.

Service Clients - webstore.iec.ch/csc

Si vous désirez nous donner des commentaires sur cette publication ou si vous avez des questions contactez-nous: csc@iec.ch.



INTERNATIONAL STANDARD

NORME INTERNATIONALE

**Connectors for electronic equipment –
Part 7-81: Detail specification for 8-way, shielded, free and fixed connectors, for
data transmissions with frequencies up to 2 000 MHz**

**Connecteurs pour équipements électroniques –
Partie 7-81: Spécification particulière pour les fiches et les embases blindées à
8 voies pour la transmission de données à des fréquences jusqu'à 2 000 MHz**

INTERNATIONAL
ELECTROTECHNICAL
COMMISSION

COMMISSION
ELECTROTECHNIQUE
INTERNATIONALE

ICS 31.220.10

ISBN 978-2-8322-3009-1

**Warning! Make sure that you obtained this publication from an authorized distributor.
Attention! Veuillez vous assurer que vous avez obtenu cette publication via un distributeur agréé.**

CONTENTS

FOREWORD.....	4
INTRODUCTION.....	6
1 Scope.....	8
2 Normative references	8
3 Terms and definitions	9
4 Cable terminations and internal connections – Fixed and free connectors	9
5 Gauge	9
6 Characteristics	9
6.1 General.....	9
6.1.1 Overview	9
6.1.2 Pin and pair grouping assignment.....	9
6.1.3 Classification into climatic category	9
6.2 Electrical characteristics	10
6.2.1 General	10
6.2.2 Transfer impedance.....	10
6.3 Transmission characteristics.....	10
6.3.1 General	10
6.3.2 Insertion loss.....	10
6.3.3 Return loss	10
6.3.4 Propagation delay.....	11
6.3.5 Delay skew	11
6.3.6 NEXT loss	11
6.3.7 Power sum NEXT loss	11
6.3.8 FEXT Loss.....	12
6.3.9 Power sum FEXT loss	12
6.3.10 Transverse conversion loss	12
6.3.11 Transverse conversion transfer loss	12
6.3.12 Coupling attenuation.....	12
6.3.13 Power sum alien (exogenous) NEXT.....	13
6.3.14 Power sum alien (exogenous) FEXT	13
6.3.15 Mechanical	13
6.3.16 Pin assignment.....	13
7 Tests and test schedule.....	14
7.1 General.....	14
7.2 Arrangement for contact resistance test.....	14
7.3 Arrangement for vibration test.....	14
7.4 Test procedures and measuring methods.....	14
7.5 Preconditioning.....	14
7.6 Wiring and mounting of specimens.....	14
7.6.1 Wiring.....	14
7.6.2 Mounting	14
8 Test schedules	14
8.1 General.....	14
8.2 Basic (minimum) test schedule.....	14
8.3 Full test schedule.....	14

8.3.1	General	14
8.3.2	Test group P preliminary.....	14
8.3.3	Test group AP	15
8.3.4	Test group BP	15
8.3.5	Test group CP	15
8.3.6	Test group DP	15
8.3.7	Test group EP	15
8.3.8	Test group FP.....	16
8.3.9	Test group GP.....	16
Bibliography.....		17
Table 1 – Test Group EP		15

INTERNATIONAL ELECTROTECHNICAL COMMISSION

CONNECTORS FOR ELECTRONIC EQUIPMENT –**Part 7-81: Detail specification for 8-way, shielded, free and fixed connectors, for data transmissions with frequencies up to 2 000 MHz**

FOREWORD

- 1) The International Electrotechnical Commission (IEC) is a worldwide organization for standardization comprising all national electrotechnical committees (IEC National Committees). The object of IEC is to promote international co-operation on all questions concerning standardization in the electrical and electronic fields. To this end and in addition to other activities, IEC publishes International Standards, Technical Specifications, Technical Reports, Publicly Available Specifications (PAS) and Guides (hereafter referred to as "IEC Publication(s)"). Their preparation is entrusted to technical committees; any IEC National Committee interested in the subject dealt with may participate in this preparatory work. International, governmental and non-governmental organizations liaising with the IEC also participate in this preparation. IEC collaborates closely with the International Organization for Standardization (ISO) in accordance with conditions determined by agreement between the two organizations.
- 2) The formal decisions or agreements of IEC on technical matters express, as nearly as possible, an international consensus of opinion on the relevant subjects since each technical committee has representation from all interested IEC National Committees.
- 3) IEC Publications have the form of recommendations for international use and are accepted by IEC National Committees in that sense. While all reasonable efforts are made to ensure that the technical content of IEC Publications is accurate, IEC cannot be held responsible for the way in which they are used or for any misinterpretation by any end user.
- 4) In order to promote international uniformity, IEC National Committees undertake to apply IEC Publications transparently to the maximum extent possible in their national and regional publications. Any divergence between any IEC Publication and the corresponding national or regional publication shall be clearly indicated in the latter.
- 5) IEC itself does not provide any attestation of conformity. Independent certification bodies provide conformity assessment services and, in some areas, access to IEC marks of conformity. IEC is not responsible for any services carried out by independent certification bodies.
- 6) All users should ensure that they have the latest edition of this publication.
- 7) No liability shall attach to IEC or its directors, employees, servants or agents including individual experts and members of its technical committees and IEC National Committees for any personal injury, property damage or other damage of any nature whatsoever, whether direct or indirect, or for costs (including legal fees) and expenses arising out of the publication, use of, or reliance upon, this IEC Publication or any other IEC Publications.
- 8) Attention is drawn to the Normative references cited in this publication. Use of the referenced publications is indispensable for the correct application of this publication.

International Standard IEC 60603-7-81 has been prepared by subcommittee 48B: Electrical connectors, of IEC technical committee 48: Electrical connectors and mechanical structures for electrical and electronic equipment.

The text of this standard is based on the following documents:

FDIS	Report on voting
48B/2451/FDIS	48B/2464/RVD

Full information on the voting for the approval of this standard can be found in the report on voting indicated in the above table.

This publication has been drafted in accordance with the ISO/IEC Directives, Part 2.

A list of all parts in the IEC 60603 series, published under the general title *Connectors for electronic equipment*, can be found on the IEC website.

The committee has decided that the contents of this publication will remain unchanged until the stability date indicated on the IEC website under "<http://webstore.iec.ch>" in the data related to the specific publication. At this date, the publication will be

- reconfirmed,
- withdrawn,
- replaced by a revised edition, or
- amended.

INTRODUCTION

IEC 60603-7 is the base specification of the whole series. Subsequent specifications do not duplicate information given in the base document, but list only additional requirements. For complete specification regarding a component of a higher number document all lower numbered documents shall be considered as well. The following diagram shows the interrelation of the documents:

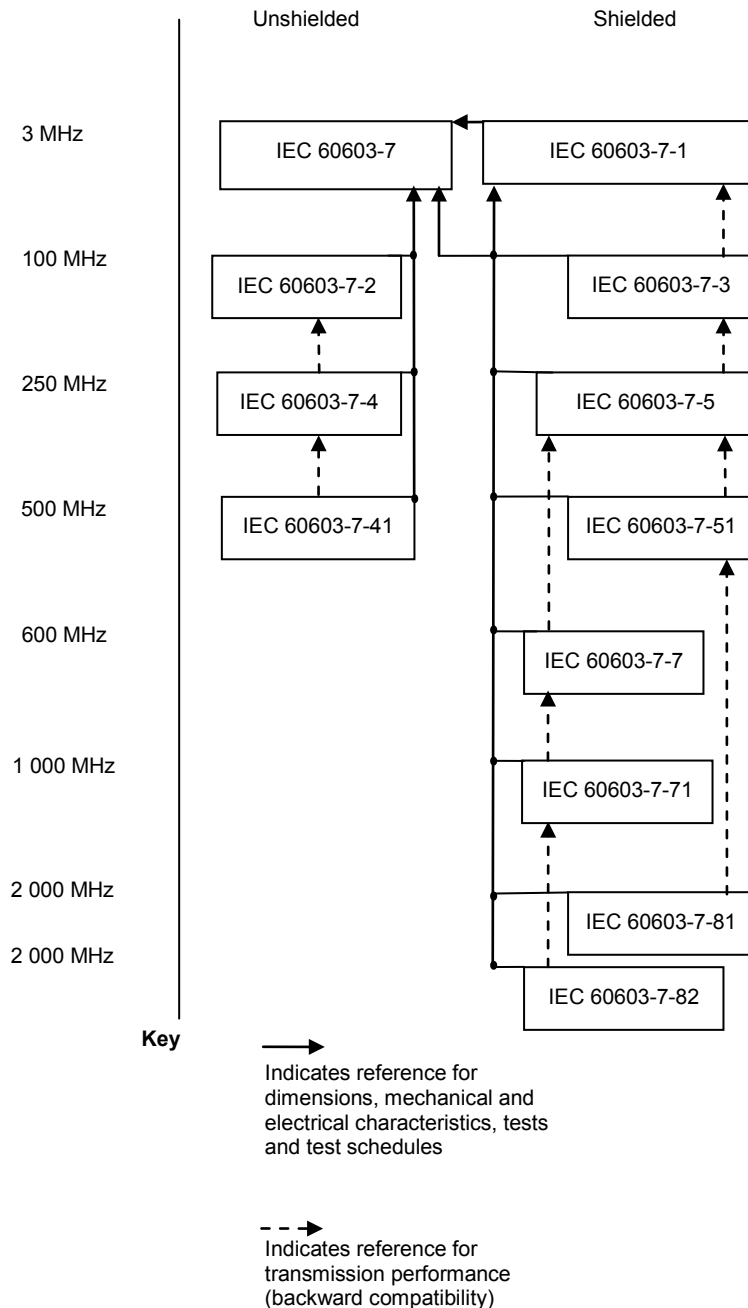

The International Electrotechnical Commission (IEC) draws attention to the fact that it is claimed that compliance with this document may involve the use of a patent concerning transmission characteristics given in 6.2.

IEC takes no position concerning the evidence, validity and scope of this patent right.

The holder of this patent right has assured the IEC that he/she is willing to negotiate licences either free of charge or under reasonable and non-discriminatory terms and conditions with applicants throughout the world. In this respect, the statement of the holder of this patent right is registered with IEC. Information may be obtained from:

CommScope INC of North Carolina
110 CommScope Place SE
Hickory North Carolina USA 28602

Attention is drawn to the possibility that some of the elements of this document may be the subject of patent rights other than those identified above. IEC shall not be held responsible for identifying any or all such patent rights.

ISO (www.iso.org/patents) and IEC (<http://patents.iec.ch>) maintain on-line data bases of patents relevant to their standards. Users are encouraged to consult the data bases for the most up to date information concerning patents.

CONNECTORS FOR ELECTRONIC EQUIPMENT –

Part 7-81: Detail specification for 8-way, shielded, free and fixed connectors, for data transmissions with frequencies up to 2 000 MHz

1 Scope

This part of IEC 60603 covers 8-way, shielded, free and fixed connectors, references dimensional, mechanical, electrical and environmental characteristics and tests in IEC 60603-7, and specifies electrical transmission requirements, including power sum alien (exogenous) crosstalk, for frequencies up to 2 000 MHz.

These connectors are typically used as “category 8.1” connectors in “class I” cabling systems specified in ISO/IEC 11801.

These connectors are intermateable and interoperable with other IEC 60603-7 series connectors as defined in Clause 2 of IEC 60603-7.

These connectors are backward compatible with other IEC 60603-7 series connectors, except IEC 60603-7-7 and IEC 60603-7-71 connectors.

NOTE Transmission performance categories: in this IEC standard, the term “category”, when used in reference to transmission performance, refers to those categories defined by ISO/IEC 11801.

2 Normative references

The following documents, in whole or in part, are normatively referenced in this document and are indispensable for its application. For dated references, only the edition cited applies. For undated references, the latest edition of the referenced document (including any amendments) applies.

IEC 60512-2-1, *Connectors for electronic equipment – Tests and measurements – Part 2-1: Electrical continuity and contact resistance tests – Test 2a: Contact resistance – Millivolt level method*

IEC 60512-25-9, *Connectors for electronic equipment – Tests and measurements – Part 25-9: Signal integrity tests – Test 25i: Alien crosstalk*

IEC 60512-26-100, *Connectors for electronic equipment – Tests and measurements – Part 26-100: Measurement setup, test and reference arrangements and measurements for connectors according to IEC 60603-7 – Tests 26a to 26g*

IEC 60512-28-100: (2nd edition under consideration) *Connectors for electronic equipment – Tests and measurements – Part 28-100: Signal integrity tests up to 2 000 MHz on IEC 60603-7 and IEC 61076-3 series connectors – Tests 28a to 28g*

IEC 60603-7:2008, *Connectors for electronic equipment – Part 7: Detail specification for 8-way, unshielded, free and fixed connectors*

IEC 60603-7-1:2011, *Connectors for electronic equipment – Part 7-1: Detail specification for 8-way, shielded, free and fixed connectors*

IEC 61156 (all parts), *Multicore and symmetrical pair/quad cables for digital communications*

IEC 62153-4-15: *Metallic communication cable test methods – Part 4-15: Electromagnetic compatibility (EMC) – Test method for measuring transfer impedance and screening attenuation or coupling attenuation with triaxial cell*¹

koniec náhľadu – text ďalej pokračuje v platenej verzii STN

¹ To be published.