

STN	Hliník a zliatiny hliníka. Lisované tyče, rúry a profily. Časť 7: Bezšvové rúry, odchýlky rozmerov a tvaru.	STN EN 755-7 42 7511
------------	--	--

Aluminium and aluminium alloys - Extruded rod/bar, tube and profiles - Part 7: Seamless tubes, tolerances on dimensions and form

Táto norma obsahuje anglickú verziu európskej normy.
This standard includes the English version of the European Standard.

Táto norma bola oznámená vo Vestníku ÚNMS SR č. 11/16

Obsahuje: EN 755-7:2016

Oznámením tejto normy sa ruší
STN EN 755-7 (42 7511) zo septembra 2008

123777

EUROPEAN STANDARD

EN 755-7

NORME EUROPÉENNE

EUROPÄISCHE NORM

June 2016

ICS 77.150.10

Supersedes EN 755-7:2008

English Version

Aluminium and aluminium alloys - Extruded rod/bar, tube and profiles - Part 7: Seamless tubes, tolerances on dimensions and form

Aluminium et alliages d'aluminium - Barres, tubes et profilés filés - Partie 7 : Tubes filés sur aiguille, tolérances sur dimensions et forme

Aluminium und Aluminiumlegierungen - Stranggepresste Stangen, Rohre und Profile - Teil 7: Nahtlose Rohre, Grenzabmaße und Formtoleranzen

This European Standard was approved by CEN on 11 April 2016.

CEN members are bound to comply with the CEN/CENELEC Internal Regulations which stipulate the conditions for giving this European Standard the status of a national standard without any alteration. Up-to-date lists and bibliographical references concerning such national standards may be obtained on application to the CEN-CENELEC Management Centre or to any CEN member.

This European Standard exists in three official versions (English, French, German). A version in any other language made by translation under the responsibility of a CEN member into its own language and notified to the CEN-CENELEC Management Centre has the same status as the official versions.

CEN members are the national standards bodies of Austria, Belgium, Bulgaria, Croatia, Cyprus, Czech Republic, Denmark, Estonia, Finland, Former Yugoslav Republic of Macedonia, France, Germany, Greece, Hungary, Iceland, Ireland, Italy, Latvia, Lithuania, Luxembourg, Malta, Netherlands, Norway, Poland, Portugal, Romania, Slovakia, Slovenia, Spain, Sweden, Switzerland, Turkey and United Kingdom.



EUROPEAN COMMITTEE FOR STANDARDIZATION
COMITÉ EUROPÉEN DE NORMALISATION
EUROPÄISCHES KOMITEE FÜR NORMUNG

CEN-CENELEC Management Centre: Avenue Marnix 17, B-1000 Brussels

Contents	Page
European foreword.....	3
1 Scope	4
2 Normative references	5
3 Alloy groups	5
4 Tolerances on dimensions	5
4.1 General	5
4.2 Diameter - Round tube	5
4.3 Width, depth or width across flats - squares, rectangles, hexagons, octagons	6
4.4 Wall thickness variation (eccentricity)	7
4.5 Length	8
4.6 Squareness of cut ends	9
5 Tolerances on form	9
5.1 General	9
5.2 Straightness	9
5.3 Convexity-Concavity	10
5.4 Twist	11
5.5 Angularity	12
5.6 Corner and fillet radii	13
5.7 Depth of dents for round tube	14
Annex A (informative) Wall thickness variation (eccentricity)	15
A.1 General	15
A.2 Specifying round tube sizes and tolerances	15
A.2.1 General	15
A.2.2 Wall thickness variation for tubes specified as $OD \times t$ or $ID \times t$	15
A.2.3 Wall thickness variation for tubes specified as $OD \times ID$	16
Bibliography	17

European foreword

This document (EN 755-7:2016) has been prepared by Technical Committee CEN/TC 132 “Aluminium and aluminium alloys”, the secretariat of which is held by AFNOR.

This European Standard shall be given the status of a national standard, either by publication of an identical text or by endorsement, at the latest by December 2016, and conflicting national standards shall be withdrawn at the latest by December 2016.

Attention is drawn to the possibility that some of the elements of this document may be the subject of patent rights. CEN [and/or CENELEC] shall not be held responsible for identifying any or all such patent rights.

This document supersedes EN 755-7:2008.

The following technical modifications have been introduced during the revision:

— Subclause 4.2, Diameter - Round tube.

EN 755 comprises the following parts under the general title *Aluminium and aluminium alloys — Extruded rod/bar, tube and profiles*:

- *Part 1: Technical conditions for inspection and delivery;*
- *Part 2: Mechanical properties;*
- *Part 3: Round bars, tolerances on dimensions and form;*
- *Part 4: Square bars, tolerances on dimensions and form;*
- *Part 5: Rectangular bars, tolerances on dimensions and form;*
- *Part 6: Hexagonal bars, tolerances on dimensions and form;*
- *Part 7: Seamless tubes, tolerances on dimensions and form;*
- *Part 8: Porthole tubes, tolerances on dimensions and form;*
- *Part 9: Profiles, tolerances on dimensions and form.*

According to the CEN/CENELEC Internal Regulations, the national standards organizations of the following countries are bound to implement this European Standard: Austria, Belgium, Bulgaria, Croatia, Cyprus, Czech Republic, Denmark, Estonia, Finland, Former Yugoslav Republic of Macedonia, France, Germany, Greece, Hungary, Iceland, Ireland, Italy, Latvia, Lithuania, Luxembourg, Malta, Netherlands, Norway, Poland, Portugal, Romania, Slovakia, Slovenia, Spain, Sweden, Switzerland, Turkey and the United Kingdom.

1 Scope

This European Standard specifies the tolerances on dimensions and form for aluminium and aluminium alloy extruded seamless tubes with an outside diameter (OD) from 8 mm to 450 mm (round tube, see Figure 1) or with a cross section contained within a circumscribing circle (CD) from 10 mm to 350 mm (other than round tube, see Figure 2), supplied in straight lengths.

This European Standard only applies to tube produced by the seamless die/mandrel method of extrusion. This standard applies to extruded seamless tube for general engineering applications only.

The temper designations used in this part are according to EN 515.

This European Standard does not apply to:

- extruded tubes produced by porthole/bridge method (EN 755-8),
- tubes delivered in coils (EN 13957),
- coiled tubes cut to length (EN 13957).

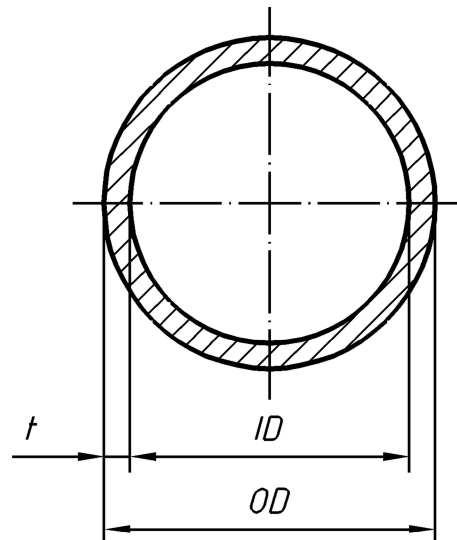

Figure 1 — Round tube

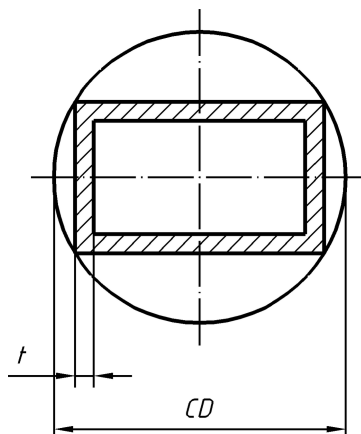

Figure 2 — Circumscribing circle for other than round tube

2 Normative references

The following documents, in whole or in part, are normatively referenced in this document and are indispensable for its application. For dated references, only the edition cited applies. For undated references, the latest edition of the referenced document (including any amendments) applies.

EN 755-1:2016, *Aluminium and aluminium alloys — Extruded rod/bar, tube and profiles — Part 1: Technical conditions for inspection and*

koniec náhľadu – text ďalej pokračuje v platenej verzii STN