

<b>STN</b>	<b>Malé čistiarne odpadových vôd do 50 EO. Časť 6: Prefabrikované čistiace prvky používané na odtok zo septikov.</b>	<b>STN EN 12566-6</b>  75 6403
------------	--	--

Small wastewater treatment systems for up to 50 PT - Part 6: Prefabricated treatment units for septic tank effluent

Táto norma obsahuje anglickú verziu európskej normy.  
This standard includes the English version of the European Standard.

Táto norma bola oznámená vo Vestníku ÚNMS SR č. 12/16

Obsahuje: EN 12566-6:2016

Oznámením tejto normy sa od 31.05.2018 ruší  
STN EN 12566-6 (75 6403) z októbra 2013

**123984**

EUROPEAN STANDARD

EN 12566-6

NORME EUROPÉENNE

EUROPÄISCHE NORM

August 2016

ICS 13.060.30

Supersedes EN 12566-6:2013

English Version

## Small wastewater treatment systems for up to 50 PT - Part 6: Prefabricated treatment units for septic tank effluent

Petites installations de traitement des eaux usées  
jusqu'à 50 PTE - Partie 6: Unités préfabriquées de  
traitement des effluents de fosses septiques

Kleinkläranlagen für bis zu 50 EW - Teil 6:  
Vorgefertigte Bauteile für die weitergehende  
Behandlung des aus Faulgruben ablaufenden  
Abwassers

This European Standard was approved by CEN on 25 June 2016.

CEN members are bound to comply with the CEN/CENELEC Internal Regulations which stipulate the conditions for giving this European Standard the status of a national standard without any alteration. Up-to-date lists and bibliographical references concerning such national standards may be obtained on application to the CEN-CENELEC Management Centre or to any CEN member.

This European Standard exists in three official versions (English, French, German). A version in any other language made by translation under the responsibility of a CEN member into its own language and notified to the CEN-CENELEC Management Centre has the same status as the official versions.

CEN members are the national standards bodies of Austria, Belgium, Bulgaria, Croatia, Cyprus, Czech Republic, Denmark, Estonia, Finland, Former Yugoslav Republic of Macedonia, France, Germany, Greece, Hungary, Iceland, Ireland, Italy, Latvia, Lithuania, Luxembourg, Malta, Netherlands, Norway, Poland, Portugal, Romania, Slovakia, Slovenia, Spain, Sweden, Switzerland, Turkey and United Kingdom.



EUROPEAN COMMITTEE FOR STANDARDIZATION  
COMITÉ EUROPÉEN DE NORMALISATION  
EUROPÄISCHES KOMITEE FÜR NORMUNG

**CEN-CENELEC Management Centre: Avenue Marnix 17, B-1000 Brussels**

<b>Contents</b>	<b>Page</b>
European foreword.....	5
<b>1 Scope</b> .....	<b>7</b>
<b>2 Normative references</b> .....	<b>7</b>
<b>3 Terms, definitions, symbols, units and abbreviated terms</b> .....	<b>7</b>
<b>3.1 Terms and definitions</b> .....	<b>7</b>
<b>3.2 Symbols and abbreviated terms</b> .....	<b>8</b>
<b>4 Products characteristics</b> .....	<b>9</b>
<b>4.1 Design</b> .....	<b>9</b>
<b>4.1.1 General</b> .....	<b>9</b>
<b>4.1.2 Overall dimensions</b> .....	<b>9</b>
<b>4.1.3 Inlets, outlets, internal pipework and connections</b> .....	<b>9</b>
<b>4.1.4 Access</b> .....	<b>9</b>
<b>4.2 Load bearing capacity</b> .....	<b>10</b>
<b>4.3 Secondary treatment efficiency</b> .....	<b>10</b>
<b>4.3.1 General</b> .....	<b>10</b>
<b>4.3.2 Secondary treatment efficiency ratio</b> .....	<b>10</b>
<b>4.3.3 Microorganism reduction</b> .....	<b>11</b>
<b>4.4 Watertightness</b> .....	<b>11</b>
<b>4.5 Power consumption</b> .....	<b>11</b>
<b>4.6 Durability</b> .....	<b>11</b>
<b>4.6.1 General</b> .....	<b>11</b>
<b>4.6.2 Concrete, steel, PVC-U, PE, GRP, PDCPD and flexible sheets</b> .....	<b>12</b>
<b>4.7 Reaction to fire</b> .....	<b>12</b>
<b>4.7.1 General</b> .....	<b>12</b>
<b>4.7.2 Units classified as Class A1 without the need for testing</b> .....	<b>12</b>
<b>4.7.3 Units classified according to the test results</b> .....	<b>12</b>
<b>4.8 Dangerous substances</b> .....	<b>13</b>
<b>5 Testing, assessing and sampling methods</b> .....	<b>13</b>
<b>5.1 Load bearing capacity</b> .....	<b>13</b>
<b>5.1.1 Generals</b> .....	<b>13</b>
<b>5.1.2 Load bearing capacity determined by calculation</b> .....	<b>13</b>
<b>5.1.3 Load bearing capacity determined by testing</b> .....	<b>14</b>
<b>5.2 Secondary treatment capacity</b> .....	<b>16</b>
<b>5.3 Watertightness</b> .....	<b>17</b>
<b>6 Assessment and verification of constancy of performance (AVCP)</b> .....	<b>17</b>
<b>6.1 General</b> .....	<b>17</b>
<b>6.2 Type testing</b> .....	<b>17</b>
<b>6.2.1 General</b> .....	<b>17</b>
<b>6.2.2 Test samples, testing and compliance criteria</b> .....	<b>18</b>
<b>6.2.3 Test reports</b> .....	<b>20</b>
<b>6.2.4 Shared other party results</b> .....	<b>20</b>
<b>6.2.5 Cascading determination of the product type results</b> .....	<b>21</b>
<b>6.3 Factory production control (FPC)</b> .....	<b>22</b>
<b>6.3.1 General</b> .....	<b>22</b>
<b>6.3.2 Requirements</b> .....	<b>22</b>

6.3.3	Product specific requirements .....	25
6.3.4	Initial inspection of factory and of FPC .....	25
6.3.5	Continuous surveillance of FPC .....	26
6.3.6	Procedure for modifications.....	26
6.3.7	One-off products, pre-production products (e.g. prototypes) and products produced in very low quantity .....	26
7	Classification and designation (Nominal designation) .....	27
8	Marking, labelling and packaging.....	27
8.1	Marking .....	27
8.2	Technical information accompanying the unit.....	28
8.3	Installation instructions.....	29
8.4	Operation and maintenance instructions.....	29
	Annex A (normative) Secondary treatment efficiency test procedure.....	31
A.1	Selection of the unit and its preliminary evaluation .....	31
A.1.1	General .....	31
A.1.2	Installation and commissioning .....	31
A.1.3	Operation and maintenance procedures during testing.....	31
A.1.4	Data to be monitored.....	31
A.2	Test procedure .....	32
A.2.1	Time for establishment .....	32
A.2.2	Influent characteristics .....	32
A.2.3	Daily flow pattern for testing .....	32
A.2.4	Test method .....	32
A.2.4.1	General .....	32
A.2.4.2	Overload.....	34
A.2.4.3	Peak flow discharge .....	34
A.2.4.4	Power breakdown/Machine breakdown.....	34
A.2.4.5	Power consumption.....	34
A.2.5	Influent and effluent sampling.....	34
A.3	Sample analysis.....	34
A.4	Test report .....	34
	Annex B (normative) Presentation of the microorganisms test results .....	36
	Annex C (informative) Analysis method.....	37
	Annex ZA (informative) Clauses of this European Standard addressing the provisions of the EU Construction Products Regulation .....	38
ZA.1	Scope and relevant characteristics .....	38
ZA.2	Procedure of attestation of conformity of prefabricated secondary treatment units.....	39
ZA.2.1	System(s) of AVCP.....	39
ZA.2.2	Declaration of performance (DoP) .....	42

<b>ZA.2.2.1</b>	<b>General .....</b>	<b>42</b>
<b>ZA.2.2.2</b>	<b>Content.....</b>	<b>43</b>
<b>ZA.2.2.3</b>	<b>Example of DoP.....</b>	<b>44</b>
<b>ZA.3</b>	<b>CE marking and labelling .....</b>	<b>47</b>
	<b>Bibliography.....</b>	<b>50</b>

## European foreword

This document (EN 12566-6:2016) has been prepared by Technical Committee CEN/TC 165 “Waste water engineering”, the secretariat of which is held by DIN.

This European Standard shall be given the status of a national standard, either by publication of an identical text or by endorsement, at the latest by February 2017, and conflicting national standards shall be withdrawn at the latest by May 2018.

Attention is drawn to the possibility that some of the elements of this document may be the subject of patent rights. CEN [and/or CENELEC] shall not be held responsible for identifying any or all such patent rights.

This document supersedes EN 12566-6:2013.

This document has been prepared under a mandate given to CEN by the European Commission and the European Free Trade Association, and supports essential requirements of EU Directive(s).

For relationship with EU Directive(s), see informative Annex ZA, which is an integral part of this document.

The differences between this version and EN 12566-6:2013 are mainly editorial changes according to the Construction Product Regulation (CPR) and declaration of power consumption and desludging during treatment efficiency test.

The standard series EN 12566 “*Small wastewater treatment systems for up to 50 PT*” contains the following parts (see Figure 1):

- *Part 1: Prefabricated septic tanks;*
- *Part 3: Packaged and/or site assembled domestic wastewater treatment plants;*
- *Part 4: Septic tanks assembled in situ from prefabricated kits;*
- *Part 6: Prefabricated treatment units for septic tank effluent (this document);*
- *Part 7: Prefabricated tertiary treatment unit.*

For filtration systems, CEN/TC 165 decided to publish the following CEN Technical reports, which are considered as Code of practices and do not specify treatment requirements:

- *Part 2: Soil infiltration systems*
- *Part 5: Pre-treated Effluent Filtration systems*

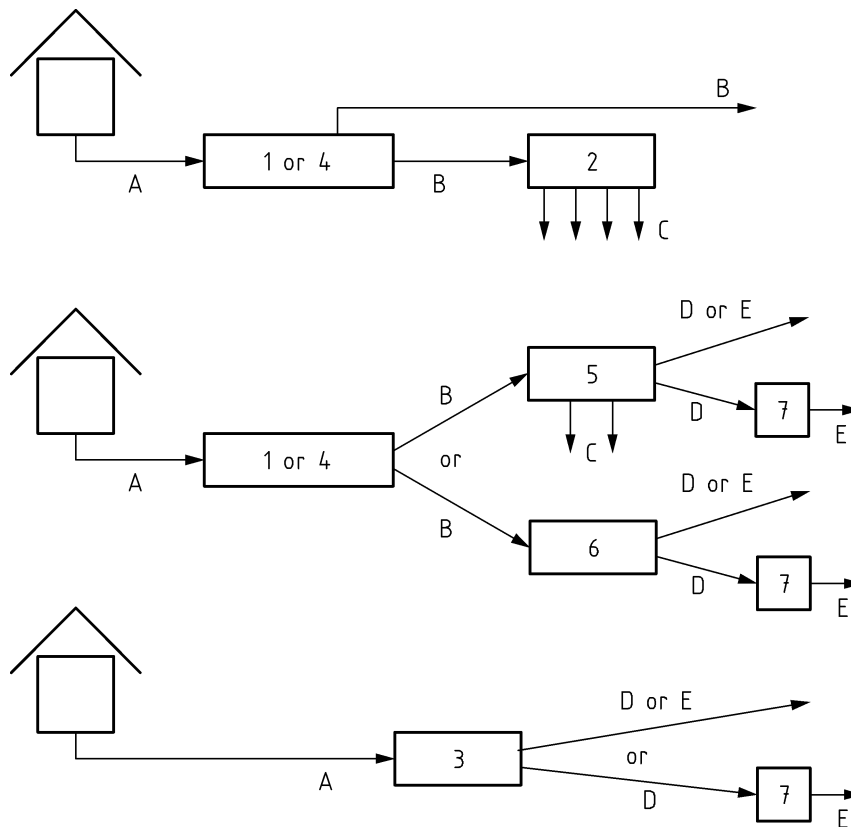
**Key**

A	domestic wastewater	1	prefabricated septic tank
B	septic tank effluent	2	soil infiltration system
C	treated infiltrated effluent	3	packaged and/or site assembled domestic wastewater treatment plant
D	treated wastewater	4	septic tank assembled <i>in situ</i> from prefabricated kit
E	tertiary treated wastewater	5	pre-treated effluent filtration system
		6	prefabricated treatment unit used for septic tank effluent
		7	prefabricated tertiary treatment unit

National regulations may specify different arrangements between the products described in the standard series EN 12566.

**Figure 1 — Scheme related to the arrangement of the parts of EN 12566 or CEN/TR 12566**

According to the CEN/CENELEC Internal Regulations, the national standards organizations of the following countries are bound to implement this European Standard: Austria, Belgium, Bulgaria, Croatia, Cyprus, Czech Republic, Denmark, Estonia, Finland, Former Yugoslav Republic of Macedonia, France, Germany, Greece, Hungary, Iceland, Ireland, Italy, Latvia, Lithuania, Luxembourg, Malta, Netherlands, Norway, Poland, Portugal, Romania, Slovakia, Slovenia, Spain, Sweden, Switzerland, Turkey and the United Kingdom.

## 1 Scope

This European Standard specifies requirements, test methods, evaluation of conformity and marking for prefabricated secondary treatment units used for the treatment of effluent from septic tanks according to EN 12566-1 or EN 12566-4 in small wastewater treatment systems for up to 50 PT.

NOTE Equivalent septic effluent may come from existing septic tanks.

It applies to the prefabricated secondary treatment unit, where all its components are packaged or site-assembled and placed on the market as a kit by one manufacturer.

The prefabricated secondary treatment unit consists of one or more tanks made of concrete, steel, unplasticised polyvinylchloride (PVC-U), polyethylene (PE), glass reinforced polyester (GRP-UP), polypropylene (PP), polydicyclopentadiene (PDCPD) or container made of flexible sheets (HDPE, PP, PVC, EPDM). Other components specified by the manufacturer, such as pipes, pumps and filter material will be considered as part of the unit.

This European Standard establishes the performance of the prefabricated secondary treatment units needed to verify their suitability for the end use conditions for which the test methods are specified.

This European Standard applies for the packaged and/or site assembled secondary treatment units for use on the top of the ground (outside the building) or buried in the ground where no vehicle loads are applied to the unit.

This European Standard does not cover:

- non watertight secondary treatment units with direct infiltration into the ground;
- retrofit kits (see definition in 3.1.7).

## 2 Normative references

The following referenced documents, in whole or in part, are normatively referenced in this document and are indispensable for its application of this document. For dated references, only the edition cited applies. For undated references, the latest edition of the referenced document (including any amendments) applies.

EN 16323:2014, *Glossary of wastewater engineering terms*

EN 12566-1, *Small wastewater treatment systems for up to 50 PT — Part 1: Prefabricated septic tanks*

EN 12566-3:2016, *Small wastewater treatment systems for up to 50 PT — Part 3: Packaged and/or site assembled domestic wastewater treatment plants*

EN 12566-4, *Small wastewater treatment systems for up to 50 PT — Part 4: Septic tanks assembled in situ from prefabricated kits*

EN 13501-1, *Fire classification of construction products and building elements — Part 1: Classification using data from reaction to fire tests*

**koniec náhľadu – text ďalej pokračuje v platenej verzii STN**