

<b>STN</b>	<b>Malé čistiarne odpadových vôd do 50 EO. Časť 1: Prefabrikované septiky.</b>	<b>STN EN 12566-1</b>  75 6403
------------	------------------------------------------------------------------------------------	------------------------------------------

Small wastewater treatment systems for up to 50 PT - Part 1: Prefabricated septic tanks

Táto norma obsahuje anglickú verziu európskej normy.  
This standard includes the English version of the European Standard.

Táto norma bola oznámená vo Vestníku ÚNMS SR č. 12/16

Obsahuje: EN 12566-1:2016

Oznámením tejto normy sa od 31.05.2018 ruší  
STN EN 12566-1 (75 6403) z novembra 2001

**123989**



EUROPEAN STANDARD

**EN 12566-1**

NORME EUROPÉENNE

EUROPÄISCHE NORM

August 2016

ICS 13.060.30

Supersedes EN 12566-1:2000

English Version

## Small wastewater treatment systems for up to 50 PT - Part 1: Prefabricated septic tanks

Petites installations de traitement des eaux usées  
jusqu'à 50 PTE - Partie 1: Fosses septiques  
préfabriquées

Kleinkläranlagen für bis zu 50 EW - Teil 1: Werkmäßig  
hergestellte Faulgruben

This European Standard was approved by CEN on 25 June 2016.

CEN members are bound to comply with the CEN/CENELEC Internal Regulations which stipulate the conditions for giving this European Standard the status of a national standard without any alteration. Up-to-date lists and bibliographical references concerning such national standards may be obtained on application to the CEN-CENELEC Management Centre or to any CEN member.

This European Standard exists in three official versions (English, French, German). A version in any other language made by translation under the responsibility of a CEN member into its own language and notified to the CEN-CENELEC Management Centre has the same status as the official versions.

CEN members are the national standards bodies of Austria, Belgium, Bulgaria, Croatia, Cyprus, Czech Republic, Denmark, Estonia, Finland, Former Yugoslav Republic of Macedonia, France, Germany, Greece, Hungary, Iceland, Ireland, Italy, Latvia, Lithuania, Luxembourg, Malta, Netherlands, Norway, Poland, Portugal, Romania, Slovakia, Slovenia, Spain, Sweden, Switzerland, Turkey and United Kingdom.



EUROPEAN COMMITTEE FOR STANDARDIZATION  
COMITÉ EUROPÉEN DE NORMALISATION  
EUROPÄISCHES KOMITEE FÜR NORMUNG

**CEN-CENELEC Management Centre: Avenue Marnix 17, B-1000 Brussels**

<b>Contents</b>	<b>Page</b>
European foreword.....	6
<b>1 Scope .....</b>	<b>8</b>
<b>2 Normative references .....</b>	<b>8</b>
<b>3 Terms and definitions .....</b>	<b>8</b>
<b>4 Product characteristics .....</b>	<b>9</b>
<b>4.1 Dimensions .....</b>	<b>9</b>
<b>4.1.1 Inlets, outlets and connections.....</b>	<b>9</b>
<b>4.1.2 Ventilation .....</b>	<b>9</b>
<b>4.1.3 Design Basis .....</b>	<b>9</b>
<b>4.2 Load bearing capacity.....</b>	<b>9</b>
<b>4.3 Watertightness.....</b>	<b>10</b>
<b>4.3.1 General.....</b>	<b>10</b>
<b>4.3.2 Water test.....</b>	<b>10</b>
<b>4.3.3 Vacuum test.....</b>	<b>10</b>
<b>4.3.4 Pneumatic pressure test.....</b>	<b>10</b>
<b>4.4 Hydraulic efficiency.....</b>	<b>10</b>
<b>4.5 Design.....</b>	<b>10</b>
<b>4.6 Access .....</b>	<b>10</b>
<b>4.7 Durability .....</b>	<b>11</b>
<b>4.8 Reaction to fire .....</b>	<b>11</b>
<b>4.8.1 General.....</b>	<b>11</b>
<b>4.8.2 Septic tank classified as Class A1 without the need for testing.....</b>	<b>11</b>
<b>4.8.3 Septic tank classified according to the test results .....</b>	<b>12</b>
<b>4.9 Dangerous substances.....</b>	<b>12</b>
<b>5 Testing, assessment and sampling methods .....</b>	<b>12</b>
<b>5.1 Load bearing capacity.....</b>	<b>12</b>
<b>5.1.1 General.....</b>	<b>12</b>
<b>5.1.2 Load bearing capacity determined by calculation .....</b>	<b>13</b>
<b>5.1.3 Load bearing capacity determined by testing .....</b>	<b>13</b>
<b>5.2 Watertightness.....</b>	<b>15</b>
<b>5.3 Hydraulic efficiency.....</b>	<b>15</b>
<b>6 Assessment and verification of constancy of performance – AVCP.....</b>	<b>16</b>
<b>6.1 General.....</b>	<b>16</b>
<b>6.2 Type testing.....</b>	<b>16</b>
<b>6.2.1 General.....</b>	<b>16</b>
<b>6.2.2 Test samples, testing and compliance criteria .....</b>	<b>17</b>
<b>6.2.3 Test reports.....</b>	<b>17</b>
<b>6.2.4 Shared other party results.....</b>	<b>17</b>
<b>6.2.5 Cascading determination of the product type results .....</b>	<b>18</b>
<b>6.3 Factory production control .....</b>	<b>19</b>
<b>6.3.1 General.....</b>	<b>19</b>
<b>6.3.2 Requirements.....</b>	<b>20</b>
<b>6.3.3 Product specific requirements.....</b>	<b>23</b>
<b>6.3.4 Initial inspection of factory and of FPC .....</b>	<b>23</b>
<b>6.3.5 Continuous surveillance of FPC.....</b>	<b>24</b>

6.3.6	Procedure for modifications.....	24
6.3.7	One-off products, pre-production products (e.g. prototypes) and products produced in very low quantity.....	24
7	Classification and designation .....	25
7.1	Classification .....	25
7.2	Nominal capacity.....	25
8	Marking, labelling and packaging.....	25
8.1	Marking .....	25
8.2	Installation instructions.....	26
8.3	Operating and maintenance instructions.....	26
<b>Annex A (normative) Watertightness and nominal capacity tests .....</b>		<b>27</b>
A.1	General .....	27
A.2	Capacity test.....	27
A.2.1	Sample .....	27
A.2.2	Procedure .....	27
A.2.3	Expression of results .....	27
A.3	Watertightness tests.....	27
A.3.1	Selection of the test.....	27
A.3.2	Water test.....	27
A.3.2.1	Sample .....	27
A.3.2.2	Procedure .....	28
A.3.2.3	Expression of results .....	28
A.3.3	Air permeability vacuum test.....	28
A.3.3.1	Sample .....	28
A.3.3.2	Procedure .....	28
A.3.3.3	Expression of results .....	29
A.3.4	Pneumatic pressure test .....	29
A.3.4.1	Sample .....	29
A.3.4.2	Procedure .....	29
A.3.4.3	Expression of results .....	30
<b>Annex B (normative) Hydraulic efficiency test.....</b>		<b>31</b>
B.1	General .....	31
B.2	Experimental apparatus.....	31
B.3	Synthetic materials used for testing .....	32
B.4	Preparation of test .....	32
B.5	Test parameters .....	32
B.6	Procedure .....	33
B.7	Calculation of test results .....	33

<b>Annex C (informative) Information for execution</b> .....	<b>34</b>
<b>C.1 Examples for outlet devices</b> .....	<b>34</b>
<b>C.2 Openings in internal walls</b> .....	<b>35</b>
<b>Annex D (normative) Test methods for structural behaviour</b> .....	<b>36</b>
<b>D.1 Selection of test method</b> .....	<b>36</b>
<b>D.2 Concrete septic tank</b> .....	<b>36</b>
<b>D.2.1 Crushing test methods</b> .....	<b>36</b>
<b>D.2.2 Test procedures</b> .....	<b>37</b>
<b>D.2.2.1 Type A test (vertical load)</b> .....	<b>37</b>
<b>D.2.2.1.1 Sample</b> .....	<b>37</b>
<b>D.2.2.1.2 Procedure</b> .....	<b>37</b>
<b>D.2.2.1.3 Expression of results</b> .....	<b>37</b>
<b>D.2.2.2 Type B test (horizontal load)</b> .....	<b>38</b>
<b>D.2.2.2.1 Sample</b> .....	<b>38</b>
<b>D.2.2.2.2 Procedure</b> .....	<b>38</b>
<b>D.2.2.2.3 Expression of results</b> .....	<b>38</b>
<b>D.2.2.3 Type C test (vertical load)</b> .....	<b>39</b>
<b>D.2.2.3.1 Sample</b> .....	<b>39</b>
<b>D.2.2.3.2 Procedure</b> .....	<b>39</b>
<b>D.2.2.3.3 Expression of results</b> .....	<b>39</b>
<b>D.3 Polyethylene septic tank</b> .....	<b>39</b>
<b>D.3.1 General</b> .....	<b>39</b>
<b>D.3.2 Vertical load test</b> .....	<b>39</b>
<b>D.3.2.1 Sample</b> .....	<b>39</b>
<b>D.3.2.2 Procedure</b> .....	<b>40</b>
<b>D.3.2.3 Expression of results</b> .....	<b>40</b>
<b>D.4 Determination of mechanical characteristics of test samples used for calculation</b> .....	<b>40</b>
<b>D.4.1 Concrete</b> .....	<b>40</b>
<b>D.4.2 Glass Reinforced Plastic</b> .....	<b>41</b>
<b>D.5 Vacuum test for Glass Reinforced Plastic or steel septic tank</b> .....	<b>41</b>
<b>D.6 Pit test</b> .....	<b>41</b>
<b>D.6.1 Sample</b> .....	<b>41</b>
<b>D.6.2 Procedure</b> .....	<b>41</b>
<b>D.6.3 Expression of results</b> .....	<b>42</b>
<b>Annex ZA (informative) Clauses of this European Standard addressing the provisions of the EU Construction Products Regulation</b> .....	<b>43</b>
<b>ZA.1 Scope and relevant characteristics</b> .....	<b>43</b>

<b>ZA.2</b>	<b>Procedure of attestation of conformity of prefabricated septic tanks</b> .....	<b>44</b>
<b>ZA.2.1</b>	<b>System(s) of AVCP</b> .....	<b>44</b>
<b>ZA.2.2</b>	<b>Declaration of performance (DoP)</b> .....	<b>47</b>
<b>ZA.2.2.1</b>	<b>General</b> .....	<b>47</b>
<b>ZA.2.2.2</b>	<b>Content</b> .....	<b>47</b>
<b>ZA.2.2.3</b>	<b>Example of DoP</b> .....	<b>48</b>
<b>ZA.3</b>	<b>CE marking and labelling</b> .....	<b>50</b>
	<b>Bibliography</b> .....	<b>53</b>

## European foreword

This document (EN 12566-1:2016) has been prepared by Technical Committee CEN/TC 165 “Waste water engineering”, the secretariat of which is held by DIN.

This European Standard shall be given the status of a national standard, either by publication of an identical text or by endorsement, at the latest by February 2017, and conflicting national standards shall be withdrawn at the latest by May 2018.

Attention is drawn to the possibility that some of the elements of this document may be the subject of patent rights. CEN [and/or CENELEC] shall not be held responsible for identifying any or all such patent rights.

This document supersedes EN 12566-1:2000.

The differences between this version and EN 12566-1:2000 are mainly editorial changes according to the Construction Product Regulation (CPR).

This document has been prepared under a mandate given to CEN by the European Commission and the European Free Trade Association, and supports essential requirements of EU Directive(s).

For relationship with EU Directive(s), see informative Annex ZA, which is an integral part of this document.

The standard series EN 12566 “Small wastewater treatment systems for up to 50 PT” contains the following parts (see Figure 1):

- *Part 1: Prefabricated septic tank (this document);*
- *Part 3: Packaged and/or site assembled domestic wastewater treatment plants;*
- *Part 4: Septic tanks assembled in situ from prefabricated kits;*
- *Part 6: Prefabricated treatment unit used for septic tank effluent;*
- *Part 7: Prefabricated tertiary treatment unit.*

For filtration systems, CEN/TC 165 decided to publish the following CEN Technical reports, which are considered as Code of practices and do not specify treatment requirements:

- *Part 2: Soil infiltration systems*
- *Part 5: Pre-treated Effluent Filtration systems*

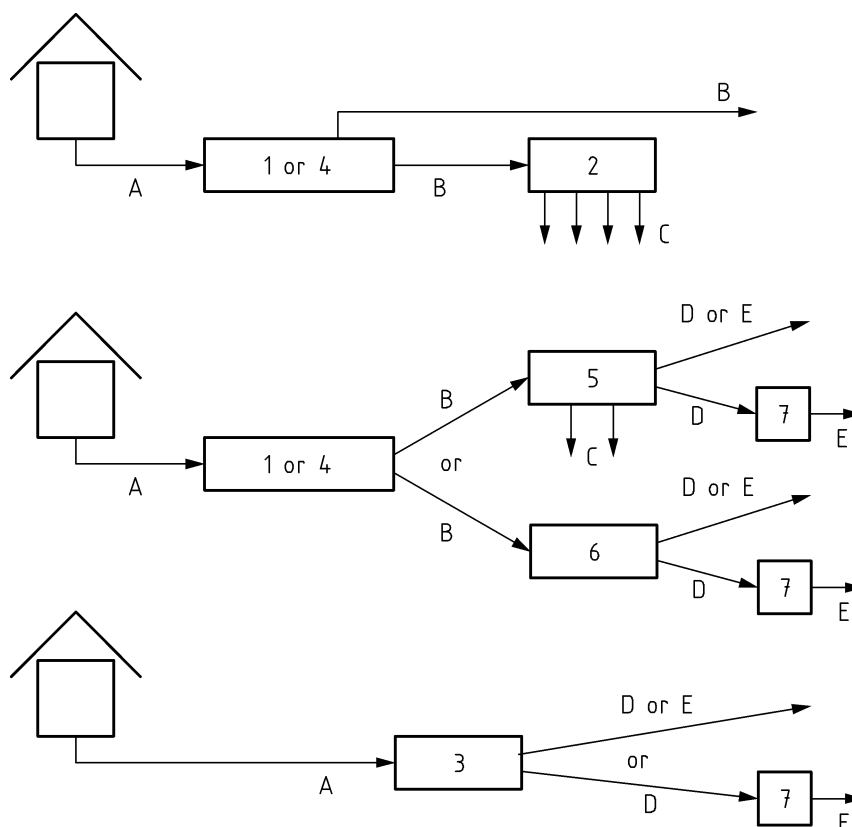
**Key**

A	domestic wastewater	1	prefabricated septic tank
B	septic tank effluent	2	soil infiltration system
C	treated infiltrated effluent	3	packaged and/or site assembled domestic wastewater treatment plant
D	treated wastewater	4	septic tank assembled <i>in situ</i> from prefabricated kit
E	tertiary treated wastewater	5	pre-treated effluent filtration system
		6	prefabricated treatment unit used for septic tank effluent
		7	prefabricated tertiary treatment unit

National regulations may specify different arrangements between the products described in the standard series EN 12566.

**Figure 1 — Scheme related to the arrangement of the parts of EN 12566**

According to the CEN/CENELEC Internal Regulations, the national standards organizations of the following countries are bound to implement this European Standard: Austria, Belgium, Bulgaria, Croatia, Cyprus, Czech Republic, Denmark, Estonia, Finland, Former Yugoslav Republic of Macedonia, France, Germany, Greece, Hungary, Iceland, Ireland, Italy, Latvia, Lithuania, Luxembourg, Malta, Netherlands, Norway, Poland, Portugal, Romania, Slovakia, Slovenia, Spain, Sweden, Switzerland, Turkey and the United Kingdom.

## 1 Scope

This part of this standard specifies the requirements for prefabricated septic tanks and ancillary equipment used for the partial treatment of domestic wastewater for a population  $\leq 50$  PT. Pipes sizes, loads, watertightness, marking and quality control are specified.

The following cases are excluded:

- 1) Septic tanks receiving grey water only;
- 2) *In situ* constructed septic tanks.

## 2 Normative references

The following documents, in whole or in part, are normatively referenced in this document and are indispensable for its application. For dated references, only the edition cited applies. For undated references, the latest edition of the referenced document (including any amendments) applies.

EN 12566-3:2016, *Small wastewater treatment systems up to 50 PT — Part 3: Packaged and/or site assembled domestic wastewater treatment plants*

EN 16323, *Glossary of wastewater engineering terms*

EN 13501-1, *Fire classification of construction products and building elements — Part 1: Classification using data from reaction to fire tests*

EN 13369, *Common rules for precast concrete products*

EN ISO 14125, *Fibre-reinforced plastic composites — Determination of flexural properties (ISO 14125)*

**koniec náhľadu – text ďalej pokračuje v platenej verzii STN**