

STN	Zhotovovanie ocel'ových a hliníkových konštrukcií Časť 5: Technické požiadavky na tenké, za studená tvarované hliníkové prvky a konštrukcie striech, stropov, podláh a stenových aplikácií	STN EN 1090-5 73 2601
------------	---	---

Execution of steel structures and aluminium structures - Part 5: Technical requirements for cold-formed structural aluminium elements and cold-formed structures for roof, ceiling, floor and wall applications

Táto norma obsahuje anglickú verziu európskej normy.
This standard includes the English version of the European Standard.

Táto norma bola oznámená vo Vestníku ÚNMS SR č. 07/17

Obsahuje: EN 1090-5:2017

125066

Úrad pre normalizáciu, metrológiu a skúšobníctvo Slovenskej republiky, 2017
Podľa zákona č. 264/1999 Z. z. o technických požiadavkách na výrobky a o posudzovaní zhody a o zmene a doplnení niektorých zákonov v znení neskorších predpisov sa slovenská technická norma a časti slovenskej technickej normy môžu rozmnožovať alebo rozširovať len so súhlasom slovenského národného normalizačného orgánu.

EUROPEAN STANDARD

EN 1090-5

NORME EUROPÉENNE

EUROPÄISCHE NORM

March 2017

ICS 91.080.13; 91.080.17

English Version

**Execution of steel structures and aluminium structures -
Part 5: Technical requirements for cold-formed structural
aluminium elements and cold-formed structures for roof,
ceiling, floor and wall applications**

Exécution des structures en acier et des structures en
aluminium - Partie 5 : Exigences techniques pour
éléments en aluminium formés à froid et structures
formées à froid pour applications en toiture, plafond,
paroi verticale et plancher

Ausführung von Stahltragwerken und
Aluminiumtragwerken - Teil 5: Technische
Anforderungen an tragende, kaltgeformte Bauelemente
aus Aluminium und tragende, kaltgeformte Bauteile für
Dach-, Decken-, Boden- und Wandanwendungen

This European Standard was approved by CEN on 6 February 2017.

CEN members are bound to comply with the CEN/CENELEC Internal Regulations which stipulate the conditions for giving this European Standard the status of a national standard without any alteration. Up-to-date lists and bibliographical references concerning such national standards may be obtained on application to the CEN-CENELEC Management Centre or to any CEN member.

This European Standard exists in three official versions (English, French, German). A version in any other language made by translation under the responsibility of a CEN member into its own language and notified to the CEN-CENELEC Management Centre has the same status as the official versions.

CEN members are the national standards bodies of Austria, Belgium, Bulgaria, Croatia, Cyprus, Czech Republic, Denmark, Estonia, Finland, Former Yugoslav Republic of Macedonia, France, Germany, Greece, Hungary, Iceland, Ireland, Italy, Latvia, Lithuania, Luxembourg, Malta, Netherlands, Norway, Poland, Portugal, Romania, Serbia, Slovakia, Slovenia, Spain, Sweden, Switzerland, Turkey and United Kingdom.



EUROPEAN COMMITTEE FOR STANDARDIZATION
COMITÉ EUROPÉEN DE NORMALISATION
EUROPÄISCHES KOMITEE FÜR NORMUNG

CEN-CENELEC Management Centre: Avenue Marnix 17, B-1000 Brussels

Contents

Page

European foreword.....	6
1 Scope	7
2 Normative references	8
3 Terms, definitions, symbols and abbreviations.....	9
3.1 Terms, definitions.....	9
3.2 Symbols and abbreviations	11
4 Specifications and documentation.....	12
4.1 Execution Specification.....	12
4.1.1 General.....	12
4.1.2 Execution classes.....	13
4.1.3 Layout drawings	13
4.1.4 Geometrical tolerances	14
4.2 Installer's documentation	14
4.2.1 General.....	14
4.2.2 Quality documentation	14
4.2.3 Safety of the erection works.....	15
4.3 Detailed traceability documentation.....	15
4.4 Execution documentation	15
5 Constituent products	15
5.1 General.....	15
5.2 Identification, inspection documents and traceability	15
5.3 Materials.....	16
5.4 Thickness tolerances	17
5.5 Minimum nominal sheet thicknesses	17
5.5.1 Profiled sheets.....	17
5.5.2 Linear structural elements.....	17
5.6 Geometrical tolerances	17
5.7 Mechanical fasteners	17
5.7.1 General.....	17
5.7.2 Materials.....	18
5.7.3 Verification of suitability.....	18
5.8 Accessories	18
5.9 Surface protection.....	18
5.10 External fire performance for roofing elements.....	18
5.10.1 Products deemed to satisfy the requirements for external fire performance.....	18
5.10.2 Products classified without the need for further testing (CWFT option)	19
5.10.3 Other products	19
5.11 Reaction to fire.....	19
5.12 Resistance to fire	19
5.13 Release of dangerous substances.....	19
5.14 Lightning protection	19
6 Manufacturing.....	19
6.1 General.....	19
6.2 Identification	19
6.3 Cold forming.....	19

6.4	Cutting.....	20
6.5	Punching	20
7	Welding at the construction site	20
8	Mechanical Fastening.....	20
8.1	General	20
8.2	Use of self-tapping and self-drilling screws	21
8.3	Use of blind rivets.....	22
8.4	Attachment of cold formed structural elements to the supporting member.....	22
8.4.1	Types of connections and attachments.....	22
8.4.2	Attachment of profiled sheets to the supporting member transverse to the direction of span.....	22
8.4.3	Attachment of profiled sheets to the supporting member parallel to the direction of span.....	24
8.4.4	Supporting member made of metal	24
8.4.5	Supporting member made of timber or other wood-based materials	24
8.4.6	Supporting member made of concrete or masonry	25
8.5	Connecting profiled sheets.....	25
8.6	Edge and field spacings of fasteners for structural elements.....	26
8.6.1	General	26
8.6.2	Edge spacings of webs of trapezoidal sheeting and liner tray profiles	26
9	Erection	26
9.1	General	26
9.2	Site conditions	26
9.3	Training / instruction of installation personnel.....	27
9.4	Inspection of preceding works	27
9.5	Layout drawing.....	27
9.6	Tools required	27
9.7	Safety on site.....	27
9.8	Inspection of packaging and contents.....	28
9.9	Storage.....	28
9.10	Damaged structural elements and connecting devices	28
9.11	Unloading, lifting gear / slings / straps	28
9.12	Laying.....	28
9.13	Direction of lay of structural aluminium components.....	29
9.14	Maintaining the cover width / adherence to tolerances	29
9.15	Condition after installation (swarf from drilling, fouling of surface, protective film wrap)	29
9.16	Inspection after installation	29
9.17	Diaphragms and moment-resisting connections in the envelope	29
9.18	Protection against lightning	30
10	Surface protection	30
10.1	Corrosion protection	30
10.2	Cleaning and maintenance	30
11	Geometrical tolerances.....	31
11.1	General	31
11.2	Tolerance types.....	31
11.3	Essential tolerances.....	32
11.3.1	General	32
11.3.2	Manufacturing tolerances.....	32
11.3.3	Erection tolerances.....	32
11.4	Functional tolerances.....	32

11.4.1	General.....	32
11.4.2	Tabulated values	32
12	Inspection, testing and correction	32
12.1	General.....	32
12.2	Structural elements.....	33
12.2.1	General.....	33
12.2.2	Non-conforming products.....	33
12.3	Manufacturing: geometrical dimensions of manufactured structural elements.....	33
12.3.1	General.....	33
12.3.2	Profiled sheets.....	33
12.4	Welding at the construction site.....	34
12.5	Inspection of fastening.....	34
12.5.1	Self-tapping and self-drilling screws.....	34
12.5.2	Blind rivets	34
	Annex A (normative) Basic requirements for profiled sheeting.....	35
A.1	General.....	35
A.2	Supporting members	35
A.3	Edges of laying area.....	35
A.3.1	Longitudinal edge stiffeners	35
A.3.2	Weakening of the cross section.....	36
A.3.3	Avoidance of ice damming	36
A.4	Building physics requirements.....	37
A.4.1	General.....	37
A.4.2	Water permeability	37
A.4.3	Thermal insulation.....	37
A.4.4	Avoidance of condensation.....	37
A.4.4.1	General.....	37
A.4.4.2	Measures against convection.....	37
A.4.5	Airborne sound insulation.....	38
A.4.6	Sound absorption.....	38
A.4.7	Protection against lightning.....	38
A.5	Roof drainage	38
	Annex B (normative) Additional design requirements for profiled sheeting.....	40
B.1	General.....	40
B.2	Serviceability	40
B.3	Dimensions, widths of supports	40
B.3.1	General.....	40
B.3.2	Supporting members made of metal (steel / aluminium).....	41
B.3.3	Supporting members made of timber.....	41
B.3.4	Supports made of concrete or masonry.....	41

B.3.5	Shear forces / fixed points	43
B.4	Eccentric attachments	43
B.5	Stiffening of liner trays	44
B.6	Walkability	45
B.6.1	Walkability during installation	45
B.6.2	Walkability and access after installation	45
B.6.3	Test “Walkability”	45
B.7	Rotational restraint	47
B.8	Stressed skin design (diaphragms)	47
B.9	Cantilevers	47
B.10	Openings in laying areas	48
	Annex C (informative) Documentation	51
	Annex D (normative) Geometrical tolerances	52
D.1	General	52
D.2	Essential and functional manufacturing tolerances – Cold formed profiled sheets	52
	Annex E (normative) Galvanic corrosion	55
	Annex F (normative) Additional information	56
F.1	List of required additional information	56
F.2	List of additional information if not otherwise specified	56
	Bibliography	58

European foreword

This document (EN 1090-5:2017) has been prepared by Technical Committee CEN/TC 135 “Execution of steel structures and aluminium structures”, the secretariat of which is held by SN.

This European Standard shall be given the status of a national standard, either by publication of an identical text or by endorsement, at the latest by September 2017, and conflicting national standards shall be withdrawn at the latest by September 2017.

Attention is drawn to the possibility that some of the elements of this document may be the subject of patent rights. CEN shall not be held responsible for identifying any or all such patent rights.

This document is part of the EN 1090 series, which comprises the following parts:

- EN 1090-1, *Execution of steel structures and aluminium structures - Part 1: Assessment and verification of constancy of performance for structural components*
- EN 1090-2, *Execution of steel structures and aluminium structures - Part 2: Technical requirements for steel structures*
- EN 1090-3, *Execution of steel structures and aluminium structures - Part 3: Technical requirements for aluminium structures*
- EN 1090-4, *Execution of steel structures and aluminium structures - Part 4: Technical requirements for cold-formed structural steel elements and cold-formed structures for roof, ceiling, floor and wall applications*
- EN 1090-5, *Execution of steel structures and aluminium structures - Part 5: Technical requirements for cold-formed structural aluminium elements and cold-formed structures for roof, ceiling, floor and wall applications*

According to the CEN-CENELEC Internal Regulations, the national standards organizations of the following countries are bound to implement this European Standard: Austria, Belgium, Bulgaria, Croatia, Cyprus, Czech Republic, Denmark, Estonia, Finland, Former Yugoslav Republic of Macedonia, France, Germany, Greece, Hungary, Iceland, Ireland, Italy, Latvia, Lithuania, Luxembourg, Malta, Netherlands, Norway, Poland, Portugal, Romania, Serbia, Slovakia, Slovenia, Spain, Sweden, Switzerland, Turkey and the United Kingdom.

1 Scope

This European Standard specifies requirements for the execution i.e. the manufacture and the installation of cold-formed structural aluminium components made from profiled sheeting for roof, ceiling, floor and wall applications under predominately static loading conditions or seismic loading conditions and their documentation. It does cover products of structural class I and II according to EN 1999-1-4 used in structures.

Structural elements are understood here to mean profiled sheeting, such as trapezoidal, sinusoidal, liner trays or cassette profiles (Figure 1), that are produced by cold forming. Perforated and micro profiled sheeting are also covered by this part.

Welded sections are excluded from this part and are covered by EN 1090-3 except seal welding in low-stress areas.

This standard also covers spacer constructions between the outer and inner or upper and lower skins as well as supporting members for roofs, walls and ceilings made from cold-formed profiled sheeting and the connections and attachments of the afore mentioned elements as long as they are involved in load transfer, it also covers connections and attachments of these elements.

A combination of steel and aluminium structural elements are permitted, e.g. liner trays made of steel, stiffened by profiles made of aluminium. In this case, EN 1090-4 and this document apply.

Composite structural elements where the interaction between dissimilar materials are an integral part of the structural behaviour such as sandwich panels and composite floors are not covered by this standard.

NOTE The structures covered in this standard can be for example

- single- or multi-skin roofs, whereby the load-bearing structure (lower skin) as well as the actual roof covering (upper skin) or both consist of structural elements;
- single- or multi-skin walls whereby the load-bearing structure (inner skin) as well as the actual cladding (outer skin) or both consist of structural elements; or
- suspended ceilings for interior fitting.

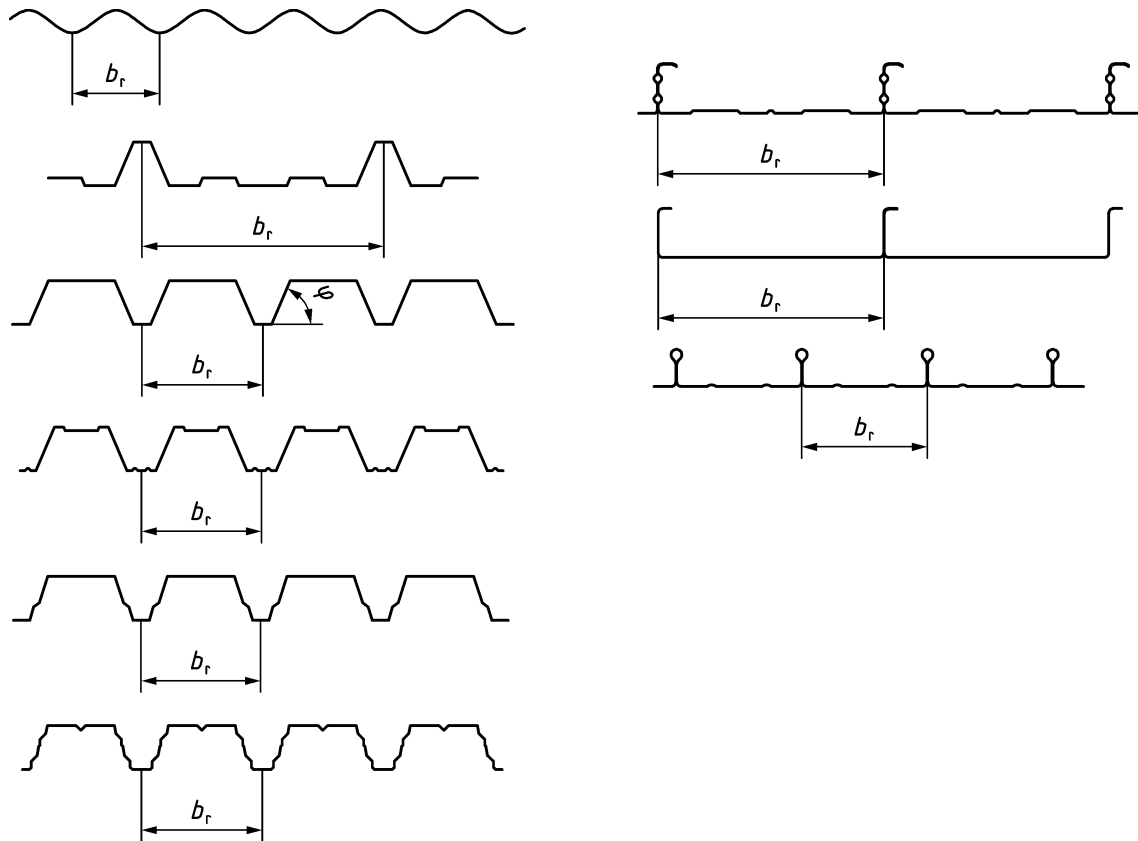

Figure 1 — Examples of profiled sheets

2 Normative references

The following documents, in whole or in part, are normatively referenced in this document and are indispensable for its application. For dated references, only the edition cited applies. For undated references, the latest edition of the referenced document (including any amendments) applies.

EN 508-2, *Roofing products from metal sheet — Specification for self-supporting products of steel, aluminium or stainless steel sheet — Part 2: Aluminium*

EN 1090-1, *Execution of steel structures and aluminium structures — Part 1: Requirements for conformity assessment of structural elements*

EN 1090-3, *Execution of steel structures and aluminium structures — Part 3: Technical requirements for aluminium structures*

CEN/TS 1187, *Test methods for external fire exposure to roofs*

EN 1995-1 (all parts), *Eurocode 5: Design of timber structures — Part 1-1: General — Common rules and rules for buildings*

EN 1999-1-1, *Eurocode 9: Design of aluminium structures — Part 1-1: General structural rules*

EN 1999-1-4, *Eurocode 9 — Design of aluminium structures — Part 1-4: Cold-formed structural sheeting*

EN 10204, *Metallic products — Types of inspection documents*

EN 13501-5, *Fire classification of construction products and building elements — Part 5: Classification using data from external fire exposure to roofs tests*

EN 62305-3:2011, *Protection against lightning — Part 3: Physical damage to structures and life hazard (IEC 62305-3:2010)*

EN ISO 376, *Metallic materials — Calibration of force-proving instruments used for the verification of uniaxial testing machines (ISO 376)*

EN ISO 717-1, *Acoustics — Rating of sound insulation in buildings and of building elements — Part 1: Airborne sound insulation (ISO 717-1)*

EN ISO 11654, *Acoustics — Sound absorbers for use in buildings — Rating of sound absorption (ISO 11654)*

koniec náhľadu – text ďalej pokračuje v platenej verzii STN