

STN	Cisterny na prepravu nebezpečných látok Digitálne rozhranie na prenos dát medzi cisternovým vozidlom a stacionárnym zariadením Časť 1: Špecifikácia protokolu Riadiace údaje, merané údaje a záznam udalostí	STN EN 15969-1 69 8524
------------	---	--

Tanks for transport of dangerous goods - Digital interface for the data transfer between tank vehicle and with stationary facilities - Part 1: Protocol specification - Control, measurement and event data

Táto norma obsahuje anglickú verziu európskej normy.
This standard includes the English version of the European Standard.

Táto norma bola oznámená vo Vestníku ÚNMS SR č. 05/18

Obsahuje: EN 15969-1:2017

Oznámením tejto normy sa ruší
STN EN 15969-1 (69 8524) z decembra 2015

126714

EUROPEAN STANDARD

EN 15969-1

NORME EUROPÉENNE

EUROPÄISCHE NORM

December 2017

ICS 35.240.60

Supersedes EN 15969-1:2015

English Version

**Tanks for transport of dangerous goods - Digital interface
for the data transfer between tank vehicle and with
stationary facilities - Part 1: Protocol specification -
Control, measurement and event data**

Citernes destinées au transport de matières
dangereuses - Interface numérique pour le transfert de
données entre des véhicules-citernes et des
installations fixes - Partie 1: Spécifications du protocole
- Contrôle, données de mesure et d'événements

Tanks für die Beförderung gefährlicher Güter - Digitale
Schnittstelle für den Datenaustausch zwischen
Tankfahrzeugen und stationären Einrichtungen - Teil
1: Protokollspezifikation - Steuerungs-, Mess- und
Ereignisdaten

This European Standard was approved by CEN on 15 October 2017.

CEN members are bound to comply with the CEN/CENELEC Internal Regulations which stipulate the conditions for giving this European Standard the status of a national standard without any alteration. Up-to-date lists and bibliographical references concerning such national standards may be obtained on application to the CEN-CENELEC Management Centre or to any CEN member.

This European Standard exists in three official versions (English, French, German). A version in any other language made by translation under the responsibility of a CEN member into its own language and notified to the CEN-CENELEC Management Centre has the same status as the official versions.

CEN members are the national standards bodies of Austria, Belgium, Bulgaria, Croatia, Cyprus, Czech Republic, Denmark, Estonia, Finland, Former Yugoslav Republic of Macedonia, France, Germany, Greece, Hungary, Iceland, Ireland, Italy, Latvia, Lithuania, Luxembourg, Malta, Netherlands, Norway, Poland, Portugal, Romania, Serbia, Slovakia, Slovenia, Spain, Sweden, Switzerland, Turkey and United Kingdom.



EUROPEAN COMMITTEE FOR STANDARDIZATION
COMITÉ EUROPÉEN DE NORMALISATION
EUROPÄISCHES KOMITEE FÜR NORMUNG

CEN-CENELEC Management Centre: Avenue Marnix 17, B-1000 Brussels

EN 15969-1:2017 (E)

Contents		Page
European foreword		4
Introduction		6
1	Scope	7
2	Normative references	7
3	Terms and definitions, abbreviations and conventions	7
3.1	Terms and definitions	7
3.2	Abbreviations	9
3.3	Conventions	9
4	Hardware interface	10
5	Basic protocol layer	10
5.1	FTL-frame (frame)	10
5.2	Frame flow (handshake)	11
5.3	Delay and timeout	16
5.4	CRC16 Checksum	16
6	Data protocol layer (FTL-data protocol)	16
6.1	Client (OBC) and server (TVE)	16
6.2	Syntax of data in datagrams	17
6.3	Nodes, subnodes, variables	18
6.4	Format identifiers	18
6.5	Types of variable values	21
6.6	Kinds of nodes	21
7	FTL-Data	23
7.1	General	23
7.2	Record and field types	23
7.3	Systemwide variables (subnode SYSTEM)	23
7.4	Variables related to global positioning system (subnode GPS)	26
7.5	Accessing a printer on TVE-side (subnode PRN)	27
7.6	Compartment information (subnode COMP)	30
7.7	Notification about changes (subnode NOTIFY)	31
7.8	Information about driver (subnode DRIVER)	32
7.9	Information about the vehicle (variable VEHICLE_ID)	33
7.10	Information about current operation (subnode OPERATION)	33
7.11	Access to filesystem on TVE (subnode FS)	35
7.12	Auxiliary (subnode AUX)	39
7.13	Order management (subnode ORDER)	40
7.14	Goods and service database (subnode PRODUCT)	44
7.15	FTL—logfile (subnodes LOG)	47
7.16	Required variables	78
7.17	NAK ID	78
8	Routing for multiple TVE	79
8.1	Purpose	79
8.2	Routing solution	79
8.3	Routing example	80

9	Communication with office	81
9.1	General	81
9.2	Simple file transfer.....	81
9.3	FTL over TCP/IP	83
10	Communication Examples.....	85
10.1	Examples for Basic Protocol Layer level	85
10.2	Examples for data protocol layer.....	87
	Annex A (normative) Node tree.....	90
	Annex B (normative) Test FTL	91
B.1	Overview	91
B.2	Basic Protocol Layer	91
B.2.1	Frame Tests.....	91
B.2.2	CRC-error.....	92
B.2.3	Delay and Timeout	92
B.3	Data Protocol Layer	92
B.3.1	Test of Toggling	92
B.3.2	Test of the FTL data layer	93
B.3.3	Test of the required FTL nodes.....	94
B.3.4	Optional System Subnodes.....	97
B.3.5	Optional Node Prn	99
B.3.6	Node Comp	101
B.4	Application Layer.....	107
B.4.1	Test of the L-File.....	107
B.4.2	Test of the LH-File.....	107
B.4.3	Test for the Filling of the NodeList	107
B.4.4	Sequence Test	108
	Bibliography	110

EN 15969-1:2017 (E)**European foreword**

This document (EN 15969-1:2017) has been prepared by Technical Committee CEN/TC 296 "Tanks for the transport of dangerous goods", the secretariat of which is held by AFNOR.

This European Standard shall be given the status of a national standard, either by publication of an identical text or by endorsement, at the latest by June 2018, and conflicting national standards shall be withdrawn at the latest by June 2018.

Attention is drawn to the possibility that some of the elements of this document may be the subject of patent rights. CEN shall not be held responsible for identifying any or all such patent rights.

This document supersedes EN 15969-1:2015.

With regard to EN 15969-1:2015, the following fundamental changes are given:

- fields for air craft refilling added.

EN 15969, *Tanks for transport of dangerous goods — Digital interface for the data transfer between tank vehicle and with stationary facilities*, consists of 2 parts:

- *Part 1: Protocol specification — Control, measurement and event data;*
- *Part 2: Commercial and logistic data.*

This European Standard forms part of a coherent standards programme comprising the following standards:

- EN 13616-1, *Overfill prevention devices for static tanks for liquid fuels — Part 1: Overfill prevention devices with closure device;*
- EN 13616-2, *Overfill prevention devices for static tanks for liquid fuels — Part 2: Overfill prevention devices without a closure device;*
- EN 13922, *Tanks for transport of dangerous goods — Service equipment for tanks — Overfill prevention systems for liquid fuels;*
- EN 14116, *Tanks for transport of dangerous goods — Digital interface for product recognition devices for liquid fuels;*
- EN 15207, *Tanks for the transport of dangerous goods — Plug/socket connection and supply characteristics for service equipment in hazardous areas with 24 V nominal supply voltage;*
- EN 15208, *Tanks for transport of dangerous goods — Sealed parcel delivery systems — Working principles and interface specifications;*
- EN 15969-2, *Tanks for transport of dangerous goods — Digital interface for the data transfer between tank vehicle and with stationary facilities — Part 2: Commercial and logistic data.*

According to the CEN/CENELEC Internal Regulations, the national standards organizations of the following countries are bound to implement this European Standard: Austria, Belgium, Bulgaria, Croatia, Cyprus, Czech Republic, Denmark, Estonia, Finland, Former Yugoslav Republic of Macedonia,

France, Germany, Greece, Hungary, Iceland, Ireland, Italy, Latvia, Lithuania, Luxembourg, Malta, Netherlands, Norway, Poland, Portugal, Romania, Serbia, Slovakia, Slovenia, Spain, Sweden, Switzerland, Turkey and the United Kingdom.

EN 15969-1:2017 (E)**Introduction**

FTL is an acronym for **Fuel Truck Link**, the interface between electronic system(s) on board of a tank vehicle (tank-vehicle-equipment) and any external computer, e.g. an on-board-computer installed in the driver's cabin; for illustration see Figure 1.

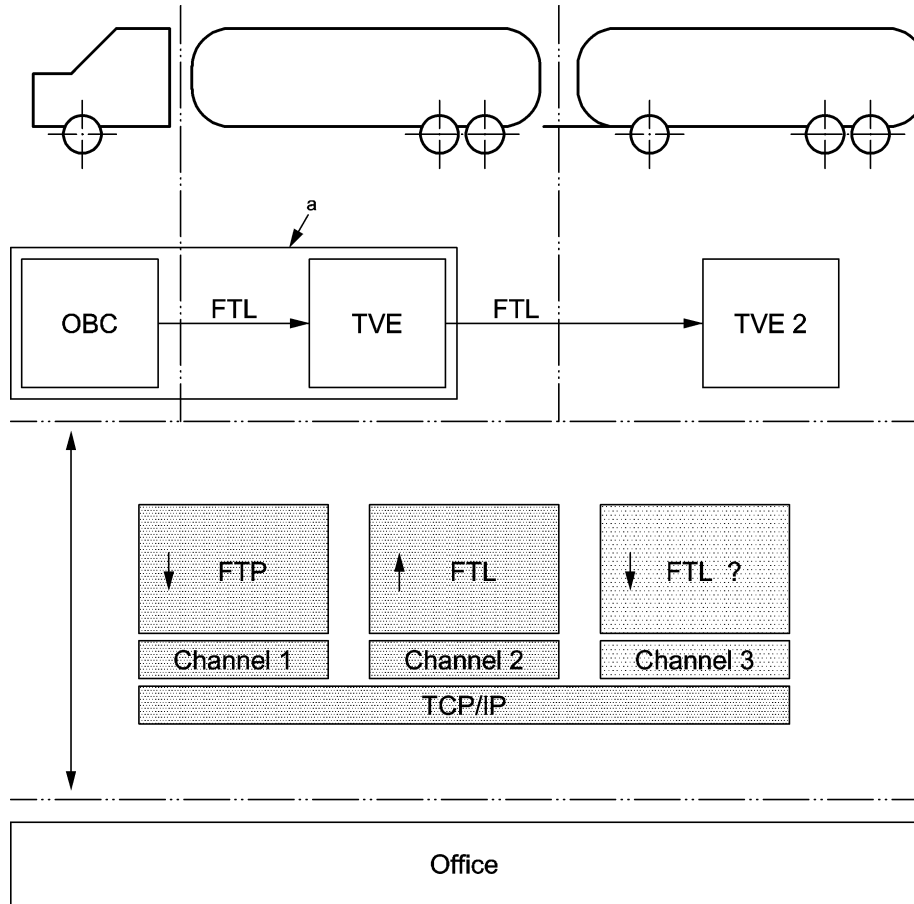
**Key**

→ direction of communication (client → server)

a may be either two independent units or one single unit which incorporates both functions OBC and TVE

Figure 1

1 Scope

This European Standard specifies data protocols and data format for the interfaces between electronic equipment (TVE), on-board computer (OBC) of the tank vehicle and stationary equipment for all interconnecting communication paths.

This European Standard specifies the basic protocol FTL used in the communication (basic protocol layer), the format and structure of FTL-data to be transmitted (data protocol layer) and describes the content of the FTL-data.

This data protocol may be used for other application e.g. between stationary tank equipment and offices.

2 Normative references

The following documents, in whole or in part, are normatively referenced in this document and are indispensable for its application. For dated references, only the edition cited applies. For undated references, the latest edition of the referenced document (including any amendments) applies.

EN 13616-2, *Overfill prevention devices for static tanks for liquid fuels — Part 2: Overfill prevention devices without a closure device*

EN 13922, *Tanks for transport of dangerous goods — Service equipment for tanks — Overfill prevention systems for liquid fuels*

EN 14116:2012+A1:2014, *Tanks for transport of dangerous goods — Digital interface for product recognition devices for liquid fuels*

EN 15208:2014, *Tanks for transport of dangerous goods — Sealed parcel delivery systems — Working principles and interface specifications*

EN 15969-2:2017, *Tanks for transport of dangerous goods — Digital interface for the data transfer between tank vehicle and with stationary facilities — Part 2: Commercial and logistic data*

ISO 639-1, *Codes for the representation of names of languages — Part 1: Alpha-2 code*

ISO/IEC 10646:2014, *Information technology — Universal Coded Character Set (UCS)*

DIN 51757:2011, *Testing of mineral oils and related materials — Determination of density*

koniec náhľadu – text ďalej pokračuje v platenej verzii STN