

<b>STN</b>	<b>Funkčné bloky (FB) na riadenie procesov a jazyk opisu elektronických zariadení (EDDL) Časť 2: Špecifikácia ponímania funkčných blokov</b>	<b>STN EN IEC 61804-2</b>  01 3756
------------	--	--

Function blocks (FB) for process control and electronic device description language (EDDL) - Part 2: Specification of FB concept

Táto norma obsahuje anglickú verziu európskej normy.  
This standard includes the English version of the European Standard.

Táto norma bola oznámená vo Vestníku ÚNMS SR č. 01/19

Obsahuje: EN IEC 61804-2:2018, IEC 61804-2:2018

Oznámením tejto normy sa od 14.02.2021 ruší  
STN EN 61804-2 (01 3756) z decembra 2007

**127765**

EUROPEAN STANDARD

**EN IEC 61804-2**

NORME EUROPÉENNE

EUROPÄISCHE NORM

March 2018

ICS 25.040.40; 35.240.50

Supersedes EN 61804-2:2007

English Version

Function blocks (FB) for process control and electronic device  
description language (EDDL) - Part 2: Specification of FB  
concept  
(IEC 61804-2:2018)

Blocs fonctionnels (FB) pour les procédés industriels et le  
langage de description électronique du produit (EDDL) -  
Partie 2: Spécification du concept de FB  
(IEC 61804-2:2018)

Funktionsbausteine für die Prozessautomation und  
elektronische Gerätebeschreibungssprache - Teil 2:  
Festlegung des Funktionsbausteinkonzepts  
(IEC 61804-2:2018)

This European Standard was approved by CENELEC on 2018-02-14. CENELEC members are bound to comply with the CEN/CENELEC Internal Regulations which stipulate the conditions for giving this European Standard the status of a national standard without any alteration.

Up-to-date lists and bibliographical references concerning such national standards may be obtained on application to the CEN-CENELEC Management Centre or to any CENELEC member.

This European Standard exists in three official versions (English, French, German). A version in any other language made by translation under the responsibility of a CENELEC member into its own language and notified to the CEN-CENELEC Management Centre has the same status as the official versions.

CENELEC members are the national electrotechnical committees of Austria, Belgium, Bulgaria, Croatia, Cyprus, the Czech Republic, Denmark, Estonia, Finland, Former Yugoslav Republic of Macedonia, France, Germany, Greece, Hungary, Iceland, Ireland, Italy, Latvia, Lithuania, Luxembourg, Malta, the Netherlands, Norway, Poland, Portugal, Romania, Serbia, Slovakia, Slovenia, Spain, Sweden, Switzerland, Turkey and the United Kingdom.



European Committee for Electrotechnical Standardization  
Comité Européen de Normalisation Electrotechnique  
Europäisches Komitee für Elektrotechnische Normung

**CEN-CENELEC Management Centre: Rue de la Science 23, B-1040 Brussels**

**EN IEC 61804-2:2018 (E)****European foreword**

The text of document 65E/567/FDIS, future edition 3 of IEC 61804-2, prepared by IEC/SC 65E "Devices and integration in enterprise systems" of IEC/TC 65 "Industrial-process measurement, control and automation" was submitted to the IEC-CENELEC parallel vote and approved by CENELEC as EN IEC 61804-2:2018.

The following dates are fixed:

- latest date by which the document has to be implemented at national level by publication of an identical national standard or by endorsement (dop) 2018-11-14
- latest date by which the national standards conflicting with the document have to be withdrawn (dow) 2021-02-14

This document supersedes EN 61804-2:2007.

Attention is drawn to the possibility that some of the elements of this document may be the subject of patent rights. CENELEC shall not be held responsible for identifying any or all such patent rights.

**Endorsement notice**

The text of the International Standard IEC 61804-2:2018 was approved by CENELEC as a European Standard without any modification.

In the official version, for Bibliography, the following notes have to be added for the standards indicated:

IEC 60854-1	NOTE	Harmonized as EN 60854-1.
IEC 61131-3	NOTE	Harmonized as EN 61131-3.
IEC 61804 series	NOTE	Harmonized as EN 61804 series.
IEC 61804-3	NOTE	Harmonized as EN 61804-3.
IEC 61804-5	NOTE	Harmonized as EN 61804-5.

## **Annex ZA** (normative)

### **Normative references to international publications with their corresponding European publications**

The following documents are referred to in the text in such a way that some or all of their content constitutes requirements of this document. For dated references, only the edition cited applies. For undated references, the latest edition of the referenced document (including any amendments) applies.

NOTE 1 Where an International Publication has been modified by common modifications, indicated by (mod), the relevant EN/HD applies.

NOTE 2 Up-to-date information on the latest versions of the European Standards listed in this annex is available here: [www.cenelec.eu](http://www.cenelec.eu).

<u>Publication</u>	<u>Year</u> <u>series</u>	<u>Title</u>	<u>EN/HD</u>	<u>Year</u> <u>series</u>
IEC 61158		Industrial communication networks - Fieldbus specifications - Part 1: Overview and guidance for the IEC 61158 and IEC 61784 series	EN 61158	
IEC 61499-1	2012	Function blocks -- Part 1: Architecture	EN 61499-1	2013
ISO/IEC 7498-1	-	Information technology - Open Systems Interconnection - Basic Reference Model: The Basic Model	-	-



IEC 61804-2

Edition 3.0 2018-01

# INTERNATIONAL STANDARD

# NORME INTERNATIONALE



**Function blocks (FB) for process control and electronic device description  
language (EDDL) –  
Part 2: Specification of FB concept**

**Blocs fonctionnels (FB) pour les procédés industriels et langage de description  
electronique de produit (EDDL) –  
Partie 2: Spécification du concept de FB**



**THIS PUBLICATION IS COPYRIGHT PROTECTED**  
**Copyright © 2018 IEC, Geneva, Switzerland**

All rights reserved. Unless otherwise specified, no part of this publication may be reproduced or utilized in any form or by any means, electronic or mechanical, including photocopying and microfilm, without permission in writing from either IEC or IEC's member National Committee in the country of the requester. If you have any questions about IEC copyright or have an enquiry about obtaining additional rights to this publication, please contact the address below or your local IEC member National Committee for further information.

Droits de reproduction réservés. Sauf indication contraire, aucune partie de cette publication ne peut être reproduite ni utilisée sous quelque forme que ce soit et par aucun procédé, électronique ou mécanique, y compris la photocopie et les microfilms, sans l'accord écrit de l'IEC ou du Comité national de l'IEC du pays du demandeur. Si vous avez des questions sur le copyright de l'IEC ou si vous désirez obtenir des droits supplémentaires sur cette publication, utilisez les coordonnées ci-après ou contactez le Comité national de l'IEC de votre pays de résidence.

IEC Central Office  
 3, rue de Varembe  
 CH-1211 Geneva 20  
 Switzerland

Tel.: +41 22 919 02 11  
[info@iec.ch](mailto:info@iec.ch)  
[www.iec.ch](http://www.iec.ch)

#### About the IEC

The International Electrotechnical Commission (IEC) is the leading global organization that prepares and publishes International Standards for all electrical, electronic and related technologies.

#### About IEC publications

The technical content of IEC publications is kept under constant review by the IEC. Please make sure that you have the latest edition, a corrigenda or an amendment might have been published.

#### IEC Catalogue - [webstore.iec.ch/catalogue](http://webstore.iec.ch/catalogue)

The stand-alone application for consulting the entire bibliographical information on IEC International Standards, Technical Specifications, Technical Reports and other documents. Available for PC, Mac OS, Android Tablets and iPad.

#### IEC publications search - [webstore.iec.ch/advsearchform](http://webstore.iec.ch/advsearchform)

The advanced search enables to find IEC publications by a variety of criteria (reference number, text, technical committee,...). It also gives information on projects, replaced and withdrawn publications.

#### IEC Just Published - [webstore.iec.ch/justpublished](http://webstore.iec.ch/justpublished)

Stay up to date on all new IEC publications. Just Published details all new publications released. Available online and also once a month by email.

#### Electropedia - [www.electropedia.org](http://www.electropedia.org)

The world's leading online dictionary of electronic and electrical terms containing 21 000 terms and definitions in English and French, with equivalent terms in 16 additional languages. Also known as the International Electrotechnical Vocabulary (IEV) online.

#### IEC Glossary - [std.iec.ch/glossary](http://std.iec.ch/glossary)

67 000 electrotechnical terminology entries in English and French extracted from the Terms and Definitions clause of IEC publications issued since 2002. Some entries have been collected from earlier publications of IEC TC 37, 77, 86 and CISPR.

#### IEC Customer Service Centre - [webstore.iec.ch/csc](http://webstore.iec.ch/csc)

If you wish to give us your feedback on this publication or need further assistance, please contact the Customer Service Centre: [sales@iec.ch](mailto:sales@iec.ch).

#### A propos de l'IEC

La Commission Electrotechnique Internationale (IEC) est la première organisation mondiale qui élabore et publie des Normes internationales pour tout ce qui a trait à l'électricité, à l'électronique et aux technologies apparentées.

#### A propos des publications IEC

Le contenu technique des publications IEC est constamment revu. Veuillez vous assurer que vous possédez l'édition la plus récente, un corrigendum ou amendement peut avoir été publié.

#### Catalogue IEC - [webstore.iec.ch/catalogue](http://webstore.iec.ch/catalogue)

Application autonome pour consulter tous les renseignements bibliographiques sur les Normes internationales, Spécifications techniques, Rapports techniques et autres documents de l'IEC. Disponible pour PC, Mac OS, tablettes Android et iPad.

#### Recherche de publications IEC - [webstore.iec.ch/advsearchform](http://webstore.iec.ch/advsearchform)

La recherche avancée permet de trouver des publications IEC en utilisant différents critères (numéro de référence, texte, comité d'études,...). Elle donne aussi des informations sur les projets et les publications remplacées ou retirées.

#### IEC Just Published - [webstore.iec.ch/justpublished](http://webstore.iec.ch/justpublished)

Restez informé sur les nouvelles publications IEC. Just Published détaille les nouvelles publications parues. Disponible en ligne et aussi une fois par mois par email.

#### Electropedia - [www.electropedia.org](http://www.electropedia.org)

Le premier dictionnaire en ligne de termes électroniques et électriques. Il contient 21 000 termes et définitions en anglais et en français, ainsi que les termes équivalents dans 16 langues additionnelles. Egalement appelé Vocabulaire Electrotechnique International (IEV) en ligne.

#### Glossaire IEC - [std.iec.ch/glossary](http://std.iec.ch/glossary)

67 000 entrées terminologiques électrotechniques, en anglais et en français, extraites des articles Termes et Définitions des publications IEC parues depuis 2002. Plus certaines entrées antérieures extraites des publications des CE 37, 77, 86 et CISPR de l'IEC.

#### Service Clients - [webstore.iec.ch/csc](http://webstore.iec.ch/csc)

Si vous désirez nous donner des commentaires sur cette publication ou si vous avez des questions contactez-nous: [sales@iec.ch](mailto:sales@iec.ch).



IEC 61804-2

Edition 3.0 2018-01

# INTERNATIONAL STANDARD

# NORME INTERNATIONALE



---

**Function blocks (FB) for process control and electronic device description  
language (EDDL) –  
Part 2: Specification of FB concept**

**Blocs fonctionnels (FB) pour les procédés industriels et langage de description  
electronique de produit (EDDL) –  
Partie 2: Spécification du concept de FB**

INTERNATIONAL  
ELECTROTECHNICAL  
COMMISSION

COMMISSION  
ELECTROTECHNIQUE  
INTERNATIONALE

---

ICS 25.040.40; 35.240.50

ISBN 978-2-8322-5128-7

**Warning! Make sure that you obtained this publication from an authorized distributor.  
Attention! Veuillez vous assurer que vous avez obtenu cette publication via un distributeur agréé.**

## CONTENTS

FOREWORD.....	5
INTRODUCTION.....	7
1 Scope.....	9
2 Normative references .....	9
3 Terms, definitions, abbreviated terms and conventions .....	9
3.1 Terms and definitions.....	9
3.2 Abbreviated terms.....	18
3.3 Conventions for lexical structures .....	19
4 General function block (FB) definition and EDD model.....	20
4.1 Device structure (device model).....	20
4.1.1 Device model description .....	20
4.1.2 FB type.....	23
4.1.3 FB execution.....	25
4.1.4 Reference between IEC 61499 and IEC 61804 models .....	26
4.1.5 UML specification of the device model .....	26
4.1.6 Classification of the algorithms .....	28
4.1.7 Algorithm description .....	29
4.1.8 Input and output variables and parameter definition .....	29
4.1.9 Choice of variables and parameters .....	30
4.1.10 Mode, Status and Diagnosis .....	30
4.2 Block combinations .....	30
4.2.1 Measurement channel.....	30
4.2.2 Actuation channel .....	31
4.2.3 Application.....	32
4.3 EDD and EDDL model.....	32
4.3.1 Overview of EDD and EDDL .....	32
4.3.2 EDD architecture .....	33
4.3.3 Concepts of EDD .....	33
4.3.4 Principles of the EDD development process .....	33
4.3.5 Interrelations between the lexical structure and formal definitions .....	34
4.3.6 Builtins .....	35
4.3.7 Profiles .....	35
5 Detailed block definition .....	35
5.1 General.....	35
5.2 Application FBs.....	35
5.2.1 Analog Input FB.....	35
5.2.2 Analog Output FB .....	37
5.2.3 Discrete Input FB .....	38
5.2.4 On/Off Actuation FB Discrete Output FB .....	40
5.2.5 Calculation FB .....	41
5.2.6 Control FB .....	42
5.3 Component FBs .....	44
5.4 Technology Block.....	44
5.4.1 Temperature Technology Block.....	44
5.4.2 Pressure Technology Block.....	47
5.4.3 Modulating Actuation Technology Block.....	49



5.4.4	On/Off Actuation Technology Block.....	51
5.5	Device (Resource) Block.....	54
5.5.1	Identification .....	54
5.5.2	Device state.....	54
5.5.3	Message .....	56
5.5.4	Initialisation .....	56
5.6	Algorithms common to all blocks .....	56
5.6.1	Data Input/Data Output status.....	56
5.6.2	Validity .....	57
5.6.3	Restart Initialisation .....	57
5.6.4	Fail-safe .....	57
5.6.5	Remote Cascade Initialisation.....	58
6	FB Environment.....	58
7	Mapping to System Management.....	58
8	Mapping to Communication .....	59
	Annex A (informative) Parameter description .....	62
	Annex B (informative) Compatibility levels .....	68
B.1	General.....	68
B.2	Compatibility .....	69
B.3	Incompatibility.....	69
B.4	Coexistence .....	70
B.5	Interconnectability.....	70
B.6	Interworkability .....	70
B.7	Interoperability.....	70
B.8	Interchangeability .....	71
	Annex C (informative) Proxy concept and its use in FB applications.....	72
C.1	General proxy concept .....	72
C.2	Use of the proxy concept in FB applications.....	73
	Bibliography.....	75
	Figure 1 – Position of IEC 61804-2 related to other standards and products .....	7
	Figure 2 – FB structure is derived out of the process (P&ID view) .....	20
	Figure 3 – FB structure may be distributed between devices (according to IEC 61499-1) .....	21
	Figure 4 – IEC 61804 FBs can be implemented in different devices .....	22
	Figure 5 – General components of devices .....	22
	Figure 6 – Block types of IEC 61804 (all parts) .....	23
	Figure 7 – IEC 61804 block overview (graphical representation not normative).....	24
	Figure 8 – UML class diagram of the device model .....	27
	Figure 9 – Measurement process signal flow.....	31
	Figure 10 – Actuation process signal flow .....	31
	Figure 11 – Application process signal flow.....	32
	Figure 12 – EDD generation process .....	34
	Figure 13 – Analog Input FB .....	36
	Figure 14 – Analog Output FB.....	37
	Figure 15 – Discrete input FB .....	39

Figure 16 – Discrete Output FB.....	40
Figure 17 – Calculation FB.....	42
Figure 18 – Control FB.....	43
Figure 19 – Temperature Technology Block.....	44
Figure 20 – Pressure Technology Block.....	48
Figure 21 – Modulating Actuation Technology Block.....	50
Figure 22 – On/Off Actuation Technology Block.....	52
Figure 23 – Harel state chart.....	55
Figure 24 – Application structure of ISO OSI Reference Model.....	59
Figure 25 – Client/Server relationship in terms of OSI Reference Model.....	60
Figure 26 – Mapping of IEC 61804 FBs to APOs.....	60
Figure B.1 – Levels of functional device compatibility.....	68
Figure C.1 – Proxy model class diagram.....	72
Figure C.2 – Proxy integration in DCS.....	73
Table 1 – Field attribute descriptions.....	19
Table 2 – Equivalences between IEC 61804 and IEC 61499 model elements.....	26
Table 3 – Variables and parameter description template.....	29
Table 4 – Example of temperature sensors of Sensor_Type.....	46
Table 5 – Device status state table.....	54
Table 6 – Device status transition table.....	56
Table A.1 – Parameter description.....	62
Table B.1 – Functionality features.....	69

## INTERNATIONAL ELECTROTECHNICAL COMMISSION

---

### **FUNCTION BLOCKS (FB) FOR PROCESS CONTROL AND ELECTRONIC DEVICE DESCRIPTION LANGUAGE (EDDL) –**

#### **Part 2: Specification of FB concept**

#### **FOREWORD**

- 1) The International Electrotechnical Commission (IEC) is a worldwide organization for standardization comprising all national electrotechnical committees (IEC National Committees). The object of IEC is to promote international co-operation on all questions concerning standardization in the electrical and electronic fields. To this end and in addition to other activities, IEC publishes International Standards, Technical Specifications, Technical Reports, Publicly Available Specifications (PAS) and Guides (hereafter referred to as "IEC Publication(s)"). Their preparation is entrusted to technical committees; any IEC National Committee interested in the subject dealt with may participate in this preparatory work. International, governmental and non-governmental organizations liaising with the IEC also participate in this preparation. IEC collaborates closely with the International Organization for Standardization (ISO) in accordance with conditions determined by agreement between the two organizations.
- 2) The formal decisions or agreements of IEC on technical matters express, as nearly as possible, an international consensus of opinion on the relevant subjects since each technical committee has representation from all interested IEC National Committees.
- 3) IEC Publications have the form of recommendations for international use and are accepted by IEC National Committees in that sense. While all reasonable efforts are made to ensure that the technical content of IEC Publications is accurate, IEC cannot be held responsible for the way in which they are used or for any misinterpretation by any end user.
- 4) In order to promote international uniformity, IEC National Committees undertake to apply IEC Publications transparently to the maximum extent possible in their national and regional publications. Any divergence between any IEC Publication and the corresponding national or regional publication shall be clearly indicated in the latter.
- 5) IEC itself does not provide any attestation of conformity. Independent certification bodies provide conformity assessment services and, in some areas, access to IEC marks of conformity. IEC is not responsible for any services carried out by independent certification bodies.
- 6) All users should ensure that they have the latest edition of this publication.
- 7) No liability shall attach to IEC or its directors, employees, servants or agents including individual experts and members of its technical committees and IEC National Committees for any personal injury, property damage or other damage of any nature whatsoever, whether direct or indirect, or for costs (including legal fees) and expenses arising out of the publication, use of, or reliance upon, this IEC Publication or any other IEC Publications.
- 8) Attention is drawn to the Normative references cited in this publication. Use of the referenced publications is indispensable for the correct application of this publication.
- 9) Attention is drawn to the possibility that some of the elements of this IEC Publication may be the subject of patent rights. IEC shall not be held responsible for identifying any or all such patent rights.

International Standard IEC 61804-2 has been prepared by subcommittee 65E: Devices and integration in enterprise systems, of IEC technical committee 65: Industrial-process measurement, control and automation.

This third edition cancels and replaces the second edition published in 2006 and integrates parts of IEC 61804-1 which was withdrawn in January 2013. This edition constitutes a technical revision.

This edition includes the following significant technical changes with respect to the previous edition:

- a) added command communication mapping in Clause 8;
- b) moved and reword compatibility level definition from IEC 62804-1 to new Annex B and terms and definitions;

c) added proxy concept in new Annex C.

The text of this standard is based on the following documents:

FDIS	Report on voting
65E/567/FDIS	65E/576/RVD

Full information on the voting for the approval of this standard can be found in the report on voting indicated in the above table.

This publication has been drafted in accordance with the ISO/IEC Directives, Part 2.

A list of all parts in the IEC 61804 series, published under the general title *Function blocks (FB) for process control and electronic device description language (EDDL)*, can be found on the IEC website.

Future standards in this series will carry the new general title as cited above. Titles of existing standards in this series will be updated at the time of the next edition.

The committee has decided that the contents of this publication will remain unchanged until the stability date indicated on the IEC web site under "<http://webstore.iec.ch>" in the data related to the specific publication. At this date, the publication will be

- reconfirmed,
- withdrawn,
- replaced by a revised edition, or
- amended.

**IMPORTANT – The 'colour inside' logo on the cover page of this publication indicates that it contains colours which are considered to be useful for the correct understanding of its contents. Users should therefore print this document using a colour printer.**

## INTRODUCTION

This part of IEC 61804 provides a conceptual function block (FB) specification, which can be mapped to specific communication systems and their accompanying definitions by industrial groups.

The EDDL fills the gap between the conceptual FB specification of this document and a product implementation. Figure 1 shows these aspects.

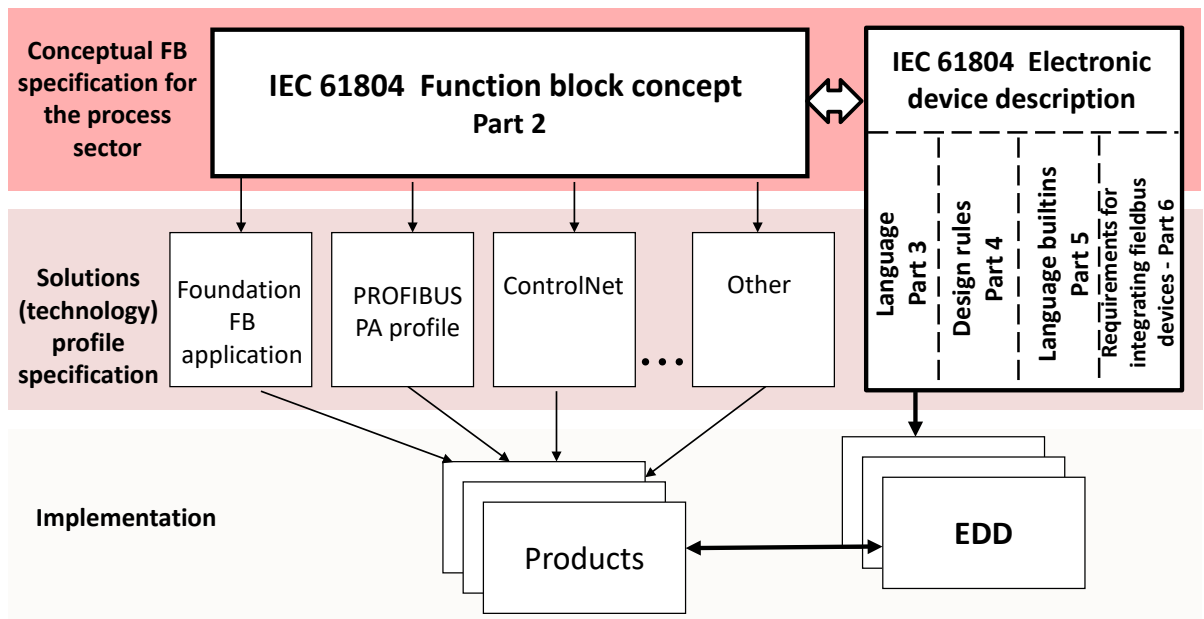

IEC

**Figure 1 – Position of IEC 61804-2 related to other standards and products**

The International Electrotechnical Commission (IEC) draws attention to the fact that it is claimed that compliance with this document may involve the use of patents

- U.S. Patent No. 5,333,114
- U.S. Patent No. 5,485,400
- U.S. Patent No. 5,825,664
- U.S. Patent No. 5,909,368
- U.S. Patent Pending No. 08/916,178
- Australian Patent No. 638507
- Canadian Patent No. 2,066,743
- European Patent No. 0495001
- Validated in:
- UK – Patent No. 0495001
- France – Patent No. 0495001
- Germany – Patent No. 69032954.7
- Netherlands – Patent No. 0495001
- Japan – Patent No. 3137643

IEC take no position concerning the evidence, validity and scope of this patent right. The holder of this patent right has assured the IEC that he is willing to negotiate licenses under reasonable and non-discriminatory terms and conditions with applicants throughout the world. In this respect, the statement of the holder of this patent right is registered with IEC. Information may be obtained from:

FieldComm Group Inc.,  
9430 Research Boulevard, Suite 1-120,  
Austin, Texas, USA 78759,  
Attention: President.

Attention is drawn to the possibility that some of the elements of this document may be the subject of patent rights other than those identified above. IEC shall not be held responsible for identifying any or all such patent rights.

ISO ([www.iso.org/patents](http://www.iso.org/patents)) and IEC (<http://patents.iec.ch>) maintain on-line data bases of patents relevant to their standards. Users are encouraged to consult the data bases for the most up to date information concerning patents.

The IEC 61804 series has the general title "Function blocks (FB) for process control and electronic device description language (EDDL)" and consists of the following parts:

Part 2: FB concept

Part 3: Electronic device description language (EDDL)

Part 4: EDD design rules

Part 5: EDDL Builtin library

Part 6: Meeting the requirements for integrating fieldbus devices in engineering tools for field devices

# FUNCTION BLOCKS (FB) FOR PROCESS CONTROL AND ELECTRONIC DEVICE DESCRIPTION LANGUAGE (EDDL) –

## Part 2: Specification of FB concept

### 1 Scope

This part of IEC 61804 is applicable to function blocks (FB) for process control.

This document specifies FB by using the result of a harmonization work as regards several elements.

- a) The device model which defines the components of an IEC 61804-2 conformant device.
- b) Conceptual specifications of FBs for measurement, actuation and processing. This includes general rules for the essential features to support control, whilst avoiding details which stop innovation as well as specialization for different industrial sectors.
- c) The electronic device description (EDD) technology, which enables the integration of real product details using the tools of the engineering life cycle.

The standardization work for FB was carried out by harmonizing the description of concepts of existing technologies. It results in an abstract level that allowed the definition of the common features in a unique way. This abstract vision is called here the "conceptual FB specification" and is mapped to specific communication systems and their accompanying definitions by the industrial groups.

NOTE This document can be mapped to ISO 15745-1.

There are solutions on the market today, which fulfil the requirements of this document and show how the conceptual specification is implemented in a given technology. New technologies will need to find equivalent solutions (see Figure 4).

### 2 Normative references

The following documents are referred to in the text in such a way that some or all of their content constitutes requirements of this document. For dated references, only the edition cited applies. For undated references, the latest edition of the referenced document (including any amendments) applies.

IEC 61158 (all parts), *Industrial communication networks – Fieldbus specifications*

IEC 61499-1:2012, *Function blocks – Part 1: Architecture*

ISO/IEC 7498-1, *Information technology – Open Systems Interconnection – Basic Reference Model: The Basic Model*

**koniec náhľadu – text ďalej pokračuje v platenej verzii STN**