

<b>STN</b>	<b>Terestriálne fotovoltaické (PV) moduly Posúdenie návrhu a typové schválenie Časť 2: Skúšobné postupy Oprava AC2</b>	<b>STN EN 61215-2/AC2</b>  36 4630
------------	--	--

Terrestrial photovoltaic (PV) modules - Design qualification and type approval - Part 2: Test procedures

Táto norma obsahuje anglickú verziu európskej normy.  
This standard includes the English version of the European Standard.

Táto norma bola oznámená vo Vestníku ÚNMS SR č. 02/19

Obsahuje: EN 61215-2:2017/AC Apr.:2018, IEC 61215-2:2016/COR1:2018

**128091**

EUROPEAN STANDARD  
NORME EUROPÉENNE  
EUROPÄISCHE NORM

**EN 61215-2:2017/AC:2018-04**

April 2018

---

ICS 27.160

English Version

**Terrestrial photovoltaic (PV) modules - Design qualification and  
type approval - Part 2: Test procedures  
(IEC 61215-2:2016/COR1:2018)**

Modules photovoltaïques (PV) pour applications terrestres -  
Qualification de la conception et homologation - Partie 2:  
Procédures d'essai  
(IEC 61215-2:2016/COR1:2018)

Terrestrische Photovoltaik(PV)-Module - Bauarteignung und  
Bauartzulassung - Teil 2: Prüfverfahren  
(IEC 61215-2:2016/COR1:2018)

This corrigendum becomes effective on 6 April 2018 for incorporation in the English language version of the EN.



European Committee for Electrotechnical Standardization  
Comité Européen de Normalisation Electrotechnique  
Europäisches Komitee für Elektrotechnische Normung

**CEN-CENELEC Management Centre: Rue de la Science 23, B-1040 Brussels**

### **Endorsement notice**

The text of the corrigendum IEC 61215-2:2016/COR1:2018 was approved by CENELEC as EN 61215-2:2017/AC:2018-04 without any modification.

IEC 61215-2:2016/COR1:2018  
© IEC 2018

– 1 –

INTERNATIONAL ELECTROTECHNICAL COMMISSION  
COMMISSION ÉLECTROTECHNIQUE INTERNATIONALE

---

**IEC 61215-2**  
Edition 1.0 2016-03

**TERRESTRIAL PHOTOVOLTAIC (PV) MODULES –  
DESIGN QUALIFICATION AND TYPE APPROVAL**

**Part 2: Test procedures**

**IEC 61215-2**  
Édition 1.0 2016-03

**MODULES PHOTOVOLTAÏQUES (PV) POUR  
APPLICATIONS TERRESTRES – QUALIFICATION  
DE LA CONCEPTION ET HOMOLOGATION**

**Partie 2: Procédures d'essai**

## CORRIGENDUM 1

Corrections to the French version appear after the English text.

Les corrections à la version française sont données après le texte anglais.

### 4.9.4 Apparatus

*Replace:*

a) "Radiant source: Natural sunlight, or a class BBB (or better) steady-state solar simulator conforming to IEC 60904-9 with an irradiance of  $(1\ 000 \pm 100)$  W/m<sup>2</sup>."

*By:*

a) "Radiant source: Natural sunlight, or a class BBB (or better) steady-state solar simulator conforming to IEC 60904-9 with an irradiance of 800 W/m<sup>2</sup> to 1 100 W/m<sup>2</sup>."

#### 4.9.5.3.1 General

*Replace:*

"The hot-spot test is performed with the module exposed to 800 W/m<sup>2</sup> to 1 000 W/m<sup>2</sup>."

*By:*

"The hot-spot test is performed with the module exposed to  $(1\ 000 \pm 100)$  W/m<sup>2</sup>."

#### 4.14.3 Test of cord anchorage (MQT 14.2)

Replace:

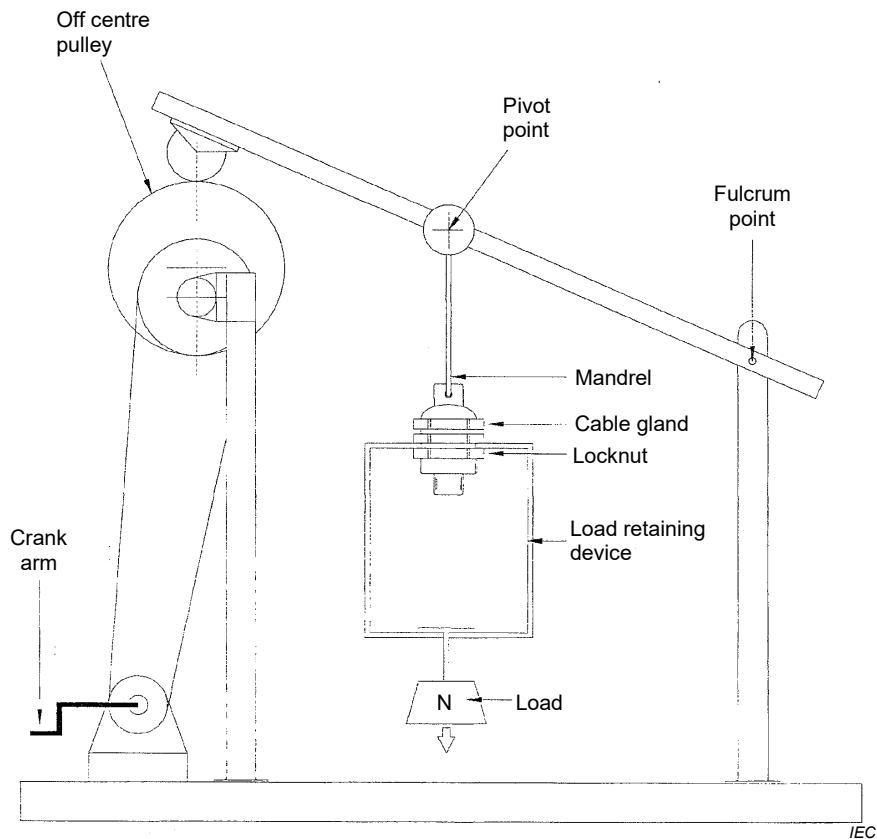

NOTE For module testing setup depends on the module construction.

**Figure 11 – Typical arrangement for the cord anchorage pull test for component testing**

By:

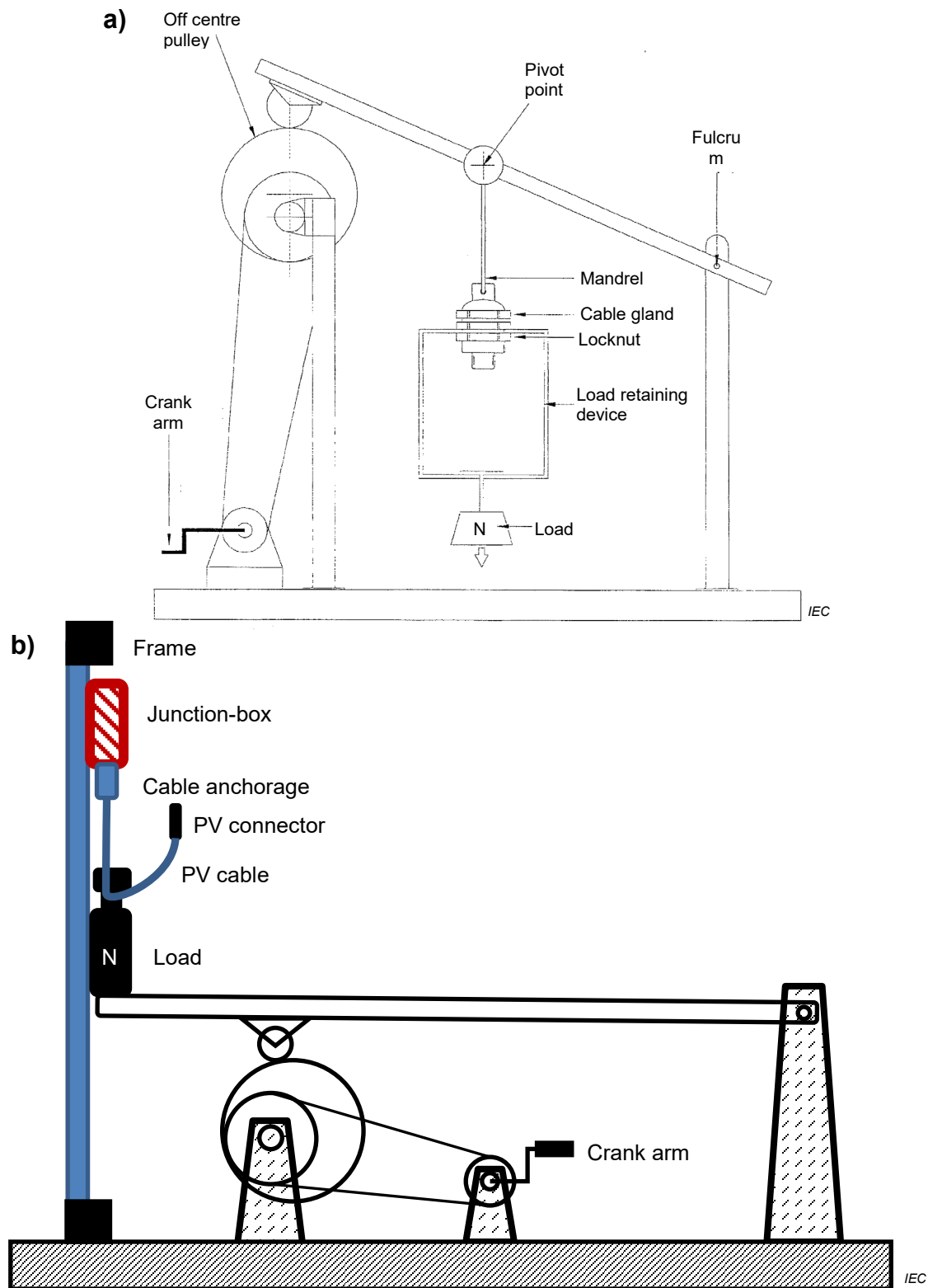

Figure 11 – a) Typical arrangement for the cord anchorage pull test for component testing from IEC 62790. b) Typical schematic arrangement for cord anchorage pull test on PV module mounted junction box

Replace:

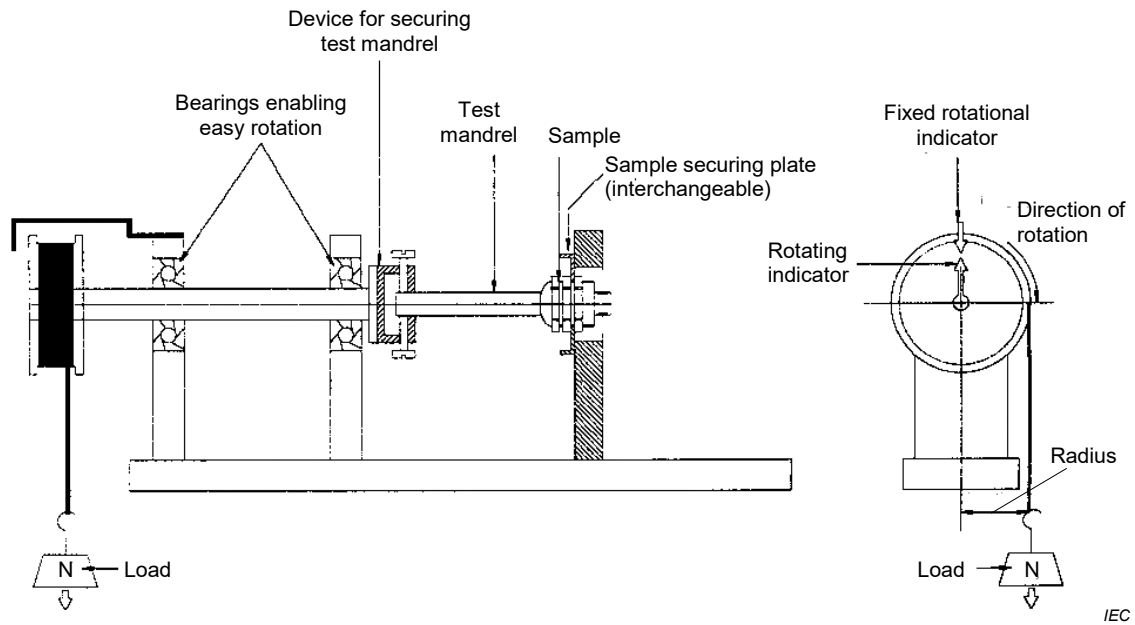
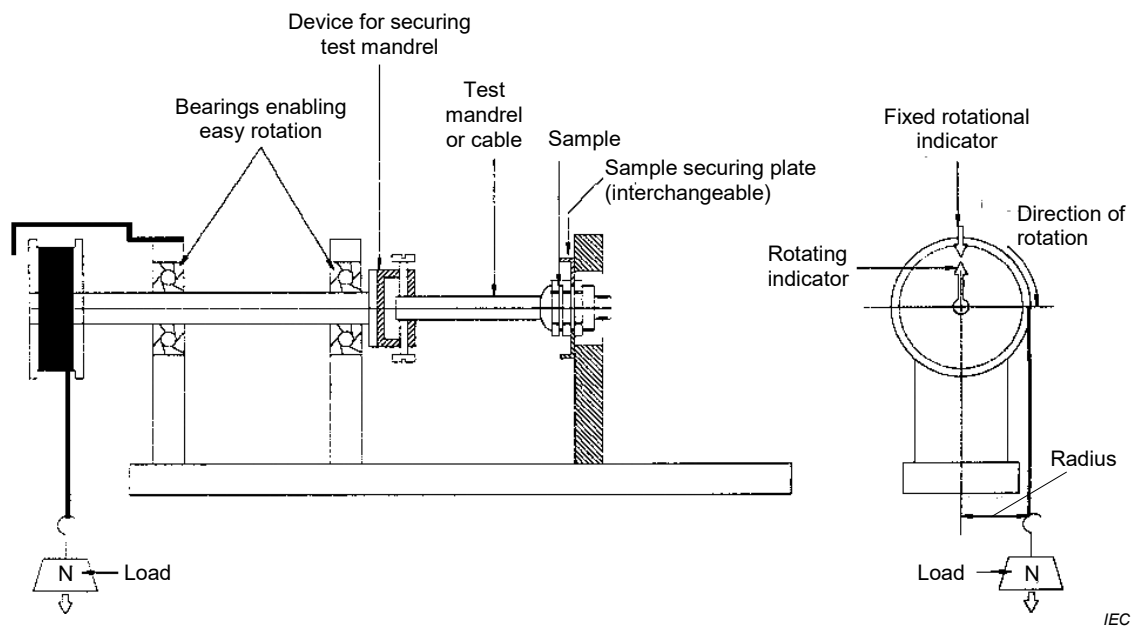

Figure 12 – Typical arrangement for torsion test

By:



If the test is performed with the manufacturer's cable, the fixture for securing the cable shall be as close as possible to the cable securing plate of the junction box.

Figure 12 – Typical arrangement for torsion test

**4.17.3 Procedure****Table 4 – Impact locations***Replace:*

3, 4	Over edges of the circuit (e.g. individual cells).
5, 6	Over the circuit near interconnects (i.e. cell interconnects and bus ribbons).

*By:*

3, 4	Over the circuit near interconnects (i.e. cell interconnects and bus ribbons).
5, 6	Over edges of the circuit (e.g. individual cells).