

STN	Konektory pre elektronické zariadenia Časť 7: Podrobná špecifikácia pre 8-pólové netienené voľné a pevné konektory	STN EN IEC 60603-7 35 4620
------------	-----------------------------------------------------------------------------------------------------------------------------------	----------------------------------------------

Connectors for electronic equipment - Part 7: Detail specification for 8-way, unshielded, free and fixed connectors

Táto norma obsahuje anglickú verziu európskej normy.
This standard includes the English version of the European Standard.

Táto norma bola oznámená vo Vestníku ÚNMS SR č. 03/21

Obsahuje: EN IEC 60603-7:2020, IEC 60603-7:2020

Oznámením tejto normy sa od 13.11.2023 ruší
STN EN 60603-7 (35 4620) z apríla 2010

132462

EUROPEAN STANDARD

EN IEC 60603-7

NORME EUROPÉENNE

EUROPÄISCHE NORM

November 2020

ICS 31.220.10

Supersedes EN 60603-7:2009 and all of its amendments
and corrigenda (if any)

English Version

**Connectors for electronic equipment - Part 7: Detail specification
for 8-way, unshielded, free and fixed connectors
(IEC 60603-7:2020)**

Connecteurs pour équipements électroniques - Partie 7:
Spécification particulière pour les fiches et les embases non
écranées à 8 voies
(IEC 60603-7:2020)

Steckverbinder für elektronische Einrichtungen - Teil 7:
Bauartspezifikation für ungeschirmte freie und feste
Steckverbinder, 8polig
(IEC 60603-7:2020)

This European Standard was approved by CENELEC on 2020-11-13. CENELEC members are bound to comply with the CEN/CENELEC Internal Regulations which stipulate the conditions for giving this European Standard the status of a national standard without any alteration.

Up-to-date lists and bibliographical references concerning such national standards may be obtained on application to the CEN-CENELEC Management Centre or to any CENELEC member.

This European Standard exists in three official versions (English, French, German). A version in any other language made by translation under the responsibility of a CENELEC member into its own language and notified to the CEN-CENELEC Management Centre has the same status as the official versions.

CENELEC members are the national electrotechnical committees of Austria, Belgium, Bulgaria, Croatia, Cyprus, the Czech Republic, Denmark, Estonia, Finland, France, Germany, Greece, Hungary, Iceland, Ireland, Italy, Latvia, Lithuania, Luxembourg, Malta, the Netherlands, Norway, Poland, Portugal, Republic of North Macedonia, Romania, Serbia, Slovakia, Slovenia, Spain, Sweden, Switzerland, Turkey and the United Kingdom.



European Committee for Electrotechnical Standardization
Comité Européen de Normalisation Electrotechnique
Europäisches Komitee für Elektrotechnische Normung

CEN-CENELEC Management Centre: Rue de la Science 23, B-1040 Brussels

EN IEC 60603-7:2020 (E)**European foreword**

The text of document 48B/2832/FDIS, future edition 4 of IEC 60603-7, prepared by SC 48B “Electrical connectors” of IEC/TC 48 “Electrical connectors and mechanical structures for electrical and electronic equipment” was submitted to the IEC-CENELEC parallel vote and approved by CENELEC as EN IEC 60603-7:2020.

The following dates are fixed:

- latest date by which the document has to be implemented at national (dop) 2021-08-13 level by publication of an identical national standard or by endorsement
- latest date by which the national standards conflicting with the (dow) 2023-11-13 document have to be withdrawn

This document supersedes EN 60603-7:2009 and all of its amendments and corrigenda (if any).

Attention is drawn to the possibility that some of the elements of this document may be the subject of patent rights. CENELEC shall not be held responsible for identifying any or all such patent rights.

Endorsement notice

The text of the International Standard IEC 60603-7:2020 was approved by CENELEC as a European Standard without any modification.

In the official version, for Bibliography, the following notes have to be added for the standards indicated:

IEC 60068-2-61:1991	NOTE	Harmonized as EN 60068-2-61:1993 (not modified)
IEC 60603-7-1	NOTE	Harmonized as EN 60603-7-1
IEC 60603-7-2	NOTE	Harmonized as EN 60603-7-2
IEC 60603-7-3	NOTE	Harmonized as EN 60603-7-3
IEC 60603-7-4	NOTE	Harmonized as EN 60603-7-4
IEC 60603-7-5	NOTE	Harmonized as EN 60603-7-5
IEC 60603-7-7	NOTE	Harmonized as EN 60603-7-7
IEC 60603-7-41	NOTE	Harmonized as EN 60603-7-41
IEC 60603-7-51	NOTE	Harmonized as EN 60603-7-51
IEC 60603-7-71	NOTE	Harmonized as EN 60603-7-71
IEC 61169-16	NOTE	Harmonized as EN 61169-16
IEC 61984	NOTE	Harmonized as EN 61984

Annex ZA (normative)

Normative references to international publications with their corresponding European publications

The following documents are referred to in the text in such a way that some or all of their content constitutes requirements of this document. For dated references, only the edition cited applies. For undated references, the latest edition of the referenced document (including any amendments) applies.

NOTE 1 Where an International Publication has been modified by common modifications, indicated by (mod), the relevant EN/HD applies.

NOTE 2 Up-to-date information on the latest versions of the European Standards listed in this annex is available here: www.cenelec.eu.

<u>Publication</u>	<u>Year</u>	<u>Title</u>	<u>EN/HD</u>	<u>Year</u>
IEC 60050-581	2008	International Electrotechnical Vocabulary - Part 581: Electromechanical components for electronic equipment	-	-
IEC 60068-1	-	Environmental testing - Part 1: General and guidance	EN 60068-1	-
IEC 60068-2-38	-	Environmental testing - Part 2-38: Tests - Test Z/AD: Composite temperature/humidity cyclic test	EN 60068-2-38	-
IEC 60352-2	-	Solderless connections - Part 2: Crimped connections - General requirements, test methods and practical guidance	EN 60352-2	-
IEC 60352-3	-	Solderless connections - Part 3: Accessible insulation displacement (ID) connections - General requirements, test methods and practical guidance	EN IEC 60352-3	-
IEC 60352-4	-	Solderless connections - Part 4: Non-accessible insulation displacement (ID) connections - General requirements, test methods and practical guidance	EN IEC 60352-4	-
IEC 60352-5	-	Solderless connections - Part 5: Press-in connections - General requirements, test methods and practical guidance	EN IEC 60352-5	-
IEC 60352-6	-	Solderless connections - Part 6: Insulation piercing connections - General requirements, test methods and practical guidance	EN 60352-6	-
IEC 60352-7	-	Solderless connections - Part 7: Spring clamp connections - General requirements, test methods and practical guidance	EN 60352-7	-
IEC 60512-1	-	Connectors for electrical and electronic equipment - Tests and measurements - Part 1: Generic specification	EN IEC 60512-1	-

EN IEC 60603-7:2020 (E)

<u>Publication</u>	<u>Year</u>	<u>Title</u>	<u>EN/HD</u>	<u>Year</u>
IEC 60512-1-1	-	Connectors for electronic equipment - Tests and measurements - Part 1-1: General examination - Test 1a: Visual examination	EN 60512-1-1	-
IEC 60512-1-2	-	Connectors for electronic equipment - Tests and measurements - Part 1-2: General examination - Test 1b: Examination of dimension and mass	EN 60512-1-2	-
IEC 60512-1-100	-	Connectors for electronic equipment - Tests and measurements - Part 1-100: General - Applicable publications	EN 60512-1-100	-
IEC 60512-2-1	-	Connectors for electronic equipment - Tests and measurements - Part 2-1: Electrical continuity and contact resistance tests - Test 2a: Contact resistance - Millivolt level method	EN 60512-2-1	-
IEC 60512-2-5	-	Connectors for electronic equipment - Tests and measurements - Part 2-5: Electrical continuity and contact resistance tests - Test 2e: Contact disturbance	EN 60512-2-5	-
IEC 60512-3-1	-	Connectors for electronic equipment - Tests and measurements - Part 3-1: Insulation tests - Test 3a: Insulation resistance	EN 60512-3-1	-
IEC 60512-4-1	-	Connectors for electronic equipment - Tests and measurements - Part 4-1: Voltage stress tests - Test 4a: Voltage proof	EN 60512-4-1	-
IEC 60512-5-2	-	Connectors for electronic equipment - Tests and measurements - Part 5-2: Current-carrying capacity tests - Test 5b: Current-temperature derating	EN 60512-5-2	-
IEC 60512-6-4	-	Connectors for electronic equipment - Tests and measurements - Part 6-4: Dynamic stress tests - Test 6d: Vibration (sinusoidal)	EN 60512-6-4	-
IEC 60512-9-1	-	Connectors for electronic equipment - Tests and measurements - Part 9-1: Endurance tests - Test 9a: Mechanical operation	EN 60512-9-1	-
IEC 60512-9-2	-	Connectors for electronic equipment - Tests and measurements - Part 9-2: Endurance tests - Test 9b: Electrical load and temperature	EN 60512-9-2	-
IEC 60512-11-4	-	Connectors for electronic equipment - Tests and measurements - Part 11-4: Climatic tests - Test 11d: Rapid change of temperature	EN 60512-11-4	-
IEC 60512-11-7	-	Connectors for electronic equipment - Tests and measurements - Part 11-7: Climatic tests - Test 11g: Flowing mixed gas corrosion test	EN 60512-11-7	-

EN IEC 60603-7:2020 (E)

<u>Publication</u>	<u>Year</u>	<u>Title</u>	<u>EN/HD</u>	<u>Year</u>
IEC 60512-13-2	-	Connectors for electronic equipment - Tests and measurements - Part 13-2: Mechanical operation tests - Test 13b: Insertion and withdrawal forces	EN 60512-13-2	-
IEC 60512-15-6	-	Connectors for electronic equipment - Tests and measurements - Part 15-6: Connector tests (mechanical) - Test 15f: Effectiveness of connector coupling devices	EN 60512-15-6	-
IEC 60603-7	series	Connectors for electronic equipment	EN 60603-7	series
IEC 60664-1	-	Insulation coordination for equipment within low-voltage supply systems - Part 1: Principles, requirements and tests	EN IEC 60664-1	-
IEC 61076-1	2006	Connectors for electronic equipment - Product requirements - Part 1: Generic specification	EN 61076-1	2006
IEC 61076-3	-	Connectors for electronic equipment - Product requirements - Part 3: Rectangular connectors - Sectional specification	EN 61076-3	-
IEC 61156-2	-	Multicore and symmetrical pair/quad cables for digital communications - Part 2: Symmetrical pair/quad cables with transmission characteristics up to 100 MHz - Horizontal floor wiring - Sectional specification	-	-
IEC 61156-3	-	Multicore and symmetrical pair/quad cables for digital communications - Part 3: Work area cable - Sectional specification	-	-
IEC 61156-4	-	Multicore and symmetrical pair/quad cables for digital communications - Part 4: Riser cables - Sectional specification	-	-
IEC 61156-5	-	Multicore and symmetrical pair/quad cables for digital communications - Part 5: Symmetrical pair/quad cables with transmission characteristics up to 1 000 MHz - Horizontal floor wiring - Sectional specification	-	-
IEC 61156-6	-	Multicore and symmetrical pair/quad cables for digital communications - Part 6: Symmetrical pair/quad cables with transmission characteristics up to 1 000 MHz - Work area wiring - Sectional specification	-	-
IEC 61156-7	-	Multicore and symmetrical pair/quad cables for digital communications - Part 7: Symmetrical pair cables with transmission characteristics up to 1 200 MHz - Sectional specification for digital and analog communication cables	-	-

EN IEC 60603-7:2020 (E)

<u>Publication</u>	<u>Year</u>	<u>Title</u>	<u>EN/HD</u>	<u>Year</u>
IEC 61760-3	-	Surface mounting technology - Part 3: Standard method for the specification of components for through hole reflow (THR) soldering	EN 61760-3	-
IEC/TR 63040	-	Guidance on clearances and creepage distances in particular for distances equal to or less than 2 mm - Test results of research on influencing parameters	-	-
ISO/IEC 11801-1	-	Information technology - Generic cabling for customer premises - Part 1: General requirements	-	-
ISO 1302	-	Geometrical Product Specifications (GPS) - Indication of surface texture in technical product documentation	EN ISO 1302	-
ITU-T Recommendation K.20	2000	Resistibility of telecommunication switching equipment to overvoltages and overcurrents	-	-
ITU-T Recommendation K.44	2000	Resistibility tests for telecommunication equipment exposed to overvoltages and overcurrents - Basic Recommendation	-	-



IEC 60603-7

Edition 4.0 2020-10

INTERNATIONAL STANDARD

NORME INTERNATIONALE



**Connectors for electronic equipment –
Part 7: Detail specification for 8-way, unshielded, free and fixed connectors**

**Connecteurs pour équipements électroniques –
Partie 7: Spécification particulière pour les fiches et les embases non écrantées
à 8 voies**

**THIS PUBLICATION IS COPYRIGHT PROTECTED****Copyright © 2020 IEC, Geneva, Switzerland**

All rights reserved. Unless otherwise specified, no part of this publication may be reproduced or utilized in any form or by any means, electronic or mechanical, including photocopying and microfilm, without permission in writing from either IEC or IEC's member National Committee in the country of the requester. If you have any questions about IEC copyright or have an enquiry about obtaining additional rights to this publication, please contact the address below or your local IEC member National Committee for further information.

Droits de reproduction réservés. Sauf indication contraire, aucune partie de cette publication ne peut être reproduite ni utilisée sous quelque forme que ce soit et par aucun procédé, électronique ou mécanique, y compris la photocopie et les microfilms, sans l'accord écrit de l'IEC ou du Comité national de l'IEC du pays du demandeur. Si vous avez des questions sur le copyright de l'IEC ou si vous désirez obtenir des droits supplémentaires sur cette publication, utilisez les coordonnées ci-après ou contactez le Comité national de l'IEC de votre pays de résidence.

IEC Central Office
3, rue de Varembe
CH-1211 Geneva 20
Switzerland

Tel.: +41 22 919 02 11
info@iec.ch
www.iec.ch

About the IEC

The International Electrotechnical Commission (IEC) is the leading global organization that prepares and publishes International Standards for all electrical, electronic and related technologies.

About IEC publications

The technical content of IEC publications is kept under constant review by the IEC. Please make sure that you have the latest edition, a corrigendum or an amendment might have been published.

IEC publications search - webstore.iec.ch/advsearchform

The advanced search enables to find IEC publications by a variety of criteria (reference number, text, technical committee,...). It also gives information on projects, replaced and withdrawn publications.

IEC Just Published - webstore.iec.ch/justpublished

Stay up to date on all new IEC publications. Just Published details all new publications released. Available online and once a month by email.

IEC Customer Service Centre - webstore.iec.ch/csc

If you wish to give us your feedback on this publication or need further assistance, please contact the Customer Service Centre: sales@iec.ch.

Electropedia - www.electropedia.org

The world's leading online dictionary on electrotechnology, containing more than 22 000 terminological entries in English and French, with equivalent terms in 16 additional languages. Also known as the International Electrotechnical Vocabulary (IEV) online.

IEC Glossary - std.iec.ch/glossary

67 000 electrotechnical terminology entries in English and French extracted from the Terms and Definitions clause of IEC publications issued since 2002. Some entries have been collected from earlier publications of IEC TC 37, 77, 86 and CISPR.

A propos de l'IEC

La Commission Electrotechnique Internationale (IEC) est la première organisation mondiale qui élabore et publie des Normes internationales pour tout ce qui a trait à l'électricité, à l'électronique et aux technologies apparentées.

A propos des publications IEC

Le contenu technique des publications IEC est constamment revu. Veuillez vous assurer que vous possédez l'édition la plus récente, un corrigendum ou amendement peut avoir été publié.

Recherche de publications IEC -**webstore.iec.ch/advsearchform**

La recherche avancée permet de trouver des publications IEC en utilisant différents critères (numéro de référence, texte, comité d'études,...). Elle donne aussi des informations sur les projets et les publications remplacées ou retirées.

IEC Just Published - webstore.iec.ch/justpublished

Restez informé sur les nouvelles publications IEC. Just Published détaille les nouvelles publications parues. Disponible en ligne et une fois par mois par email.

Service Clients - webstore.iec.ch/csc

Si vous désirez nous donner des commentaires sur cette publication ou si vous avez des questions contactez-nous: sales@iec.ch.

Electropedia - www.electropedia.org

Le premier dictionnaire d'électrotechnologie en ligne au monde, avec plus de 22 000 articles terminologiques en anglais et en français, ainsi que les termes équivalents dans 16 langues additionnelles. Egalement appelé Vocabulaire Electrotechnique International (IEV) en ligne.

Glossaire IEC - std.iec.ch/glossary

67 000 entrées terminologiques électrotechniques, en anglais et en français, extraites des articles Termes et Définitions des publications IEC parues depuis 2002. Plus certaines entrées antérieures extraites des publications des CE 37, 77, 86 et CISPR de l'IEC.



IEC 60603-7

Edition 4.0 2020-10

INTERNATIONAL STANDARD

NORME INTERNATIONALE



**Connectors for electronic equipment –
Part 7: Detail specification for 8-way, unshielded, free and fixed connectors**

**Connecteurs pour équipements électroniques –
Partie 7: Spécification particulière pour les fiches et les embases non écrantées
à 8 voies**

INTERNATIONAL
ELECTROTECHNICAL
COMMISSION

COMMISSION
ELECTROTECHNIQUE
INTERNATIONALE

ICS 31.220.01

ISBN 978-2-8322-8894-8

**Warning! Make sure that you obtained this publication from an authorized distributor.
Attention! Veuillez vous assurer que vous avez obtenu cette publication via un distributeur agréé.**

CONTENTS

FOREWORD	5
INTRODUCTION	7
1 Scope	8
2 Normative references	8
3 Terms and definitions	10
4 Common features and typical connector pair	12
4.1 View showing typical fixed and free connectors (see Figure 2)	12
4.2 Mating information	13
4.2.1 General	13
4.2.2 Contacts – mating conditions	14
4.2.3 Fixed connector	16
4.2.4 Free connector	19
5 Cable terminations and internal connections – Fixed and free connectors	20
5.1 General	20
5.2 Termination types	21
5.2.1 Solder terminations	21
5.2.2 Solderless terminations	21
6 Gauges	21
6.1 Fixed connectors	21
6.2 Free connectors	24
7 Characteristics	27
7.1 General	27
7.2 Pin and pair grouping assignment	27
7.3 Classification into climatic category	27
7.4 Electrical characteristics	28
7.4.1 Creepage and clearance distances	28
7.4.2 Voltage proof	28
7.4.3 Current-temperature derating	28
7.4.4 Interface contact resistance – initial only	29
7.4.5 Input to output DC resistance	29
7.4.6 Input-to-output DC resistance unbalance	29
7.4.7 Initial insulation resistance	30
7.4.8 Transfer impedance	30
7.5 Transmission characteristics	30
7.6 Mechanical characteristics	30
7.6.1 Mechanical operation	30
7.6.2 Effectiveness of connector coupling devices	30
7.6.3 Insertion and withdrawal forces	30
8 Tests and test schedule	30
8.1 General	30
8.2 Arrangement for interface contact resistance test	31
8.3 Arrangement for vibration test (test phase CP1)	32
8.4 Test procedures and measuring methods	32
8.5 Preconditioning	33
8.6 Wiring and mounting of specimens	33

8.6.1	Wiring	33
8.6.2	Mounting	33
8.7	Test schedules.....	33
8.7.1	General	33
8.7.2	Basic (minimum) test schedule	33
8.7.3	Full test schedule	33
Annex A (normative)	Gauging continuity procedure.....	40
A.1	Object.....	40
A.2	Preparation of the specimens.....	40
A.3	Test method.....	40
A.4	Final measurements.....	40
A.5	Description of the continuity gauge	40
Annex B (normative)	Locking device mechanical operation	43
B.1	Object.....	43
B.2	Preparation of the specimens.....	43
B.3	Test method.....	43
B.4	Final measurements.....	43
Annex C (normative)	Gauge requirements	44
C.1	Fixed connectors	44
C.2	Free connectors	44
Annex D (normative)	Keystone connector information	45
D.1	Fixed connector, female contacts Keystone type – Type A, variant 03 in the previous edition of this standard	45
D.2	Mounting dimensions for type A, Keystone type variant 03.....	46
Annex E (normative)	Levels of compatibility.....	47
E.1	General.....	47
E.2	Intermountability	48
E.3	Intermateability	49
E.4	Intermountability and intermateability.....	49
E.5	Interoperability	50
E.6	Interchangeability	50
E.7	Backward compatibility	50
Bibliography.....		52
Figure 1 – IEC 60603-7 family document diagram		7
Figure 2 – View showing typical fixed and free connectors.....		12
Figure 3 – Contact interface dimensions with terminated free connector		14
Figure 4 – Fixed connector details		17
Figure 5 – Free connector view.....		19
Figure 6 – Fixed connector "Go" gauge.....		22
Figure 7 – Fixed connector "No-go" gauges		23
Figure 8 – Free connector "No-go" gauges.....		25
Figure 9 – Free connector "Go" gauge		26
Figure 10 – Fixed connector pin and pair grouping assignment (front view of connector)		27
Figure 11 – Connector de-rating curve		29
Figure 12 – Arrangement for interface contact resistance test.....		31

Figure 13 – Arrangement for vibration test	32
Figure A.1 – Continuity gauge.....	42
Figure A.2 – Continuity gauge insertion	42
Figure D.1 – Keystone connector	45
Figure D.2 – Panel drawing.....	46
Table 1 – Dimensions for Figure 3	15
Table 2 – Dimensions for Figure 4	18
Table 3 – Dimensions for Figure 5	20
Table 4 – Dimensions for Figure 6 and Figure 7	24
Table 5 – Dimensions for Figure 8	25
Table 6 – Dimensions for Figure 9	26
Table 7 – Climatic categories – selected values	27
Table 8 – Creepage and clearance distances.....	28
Table 9 – Test group P	34
Table 10 – Test group AP	34
Table 11 – Test group BP	36
Table 12 – Test group CP	37
Table 13 – Test group DP	38
Table 14 – Test group EP	39
Table 15 – Test group FP	39
Table A.1 – Dimensions for Figure A.1	41
Table D.1 – Dimensions for Figure D.1	45
Table D.2 – Dimensions for Figure D.2	46
Table E.1 – Levels of compatibility and required parameters.....	48

INTERNATIONAL ELECTROTECHNICAL COMMISSION

CONNECTORS FOR ELECTRONIC EQUIPMENT –**Part 7: Detail specification for 8-way, unshielded,
free and fixed connectors**

FOREWORD

- 1) The International Electrotechnical Commission (IEC) is a worldwide organization for standardization comprising all national electrotechnical committees (IEC National Committees). The object of IEC is to promote international co-operation on all questions concerning standardization in the electrical and electronic fields. To this end and in addition to other activities, IEC publishes International Standards, Technical Specifications, Technical Reports, Publicly Available Specifications (PAS) and Guides (hereafter referred to as “IEC Publication(s)”). Their preparation is entrusted to technical committees; any IEC National Committee interested in the subject dealt with may participate in this preparatory work. International, governmental and non-governmental organizations liaising with the IEC also participate in this preparation. IEC collaborates closely with the International Organization for Standardization (ISO) in accordance with conditions determined by agreement between the two organizations.
- 2) The formal decisions or agreements of IEC on technical matters express, as nearly as possible, an international consensus of opinion on the relevant subjects since each technical committee has representation from all interested IEC National Committees.
- 3) IEC Publications have the form of recommendations for international use and are accepted by IEC National Committees in that sense. While all reasonable efforts are made to ensure that the technical content of IEC Publications is accurate, IEC cannot be held responsible for the way in which they are used or for any misinterpretation by any end user.
- 4) In order to promote international uniformity, IEC National Committees undertake to apply IEC Publications transparently to the maximum extent possible in their national and regional publications. Any divergence between any IEC Publication and the corresponding national or regional publication shall be clearly indicated in the latter.
- 5) IEC itself does not provide any attestation of conformity. Independent certification bodies provide conformity assessment services and, in some areas, access to IEC marks of conformity. IEC is not responsible for any services carried out by independent certification bodies.
- 6) All users should ensure that they have the latest edition of this publication.
- 7) No liability shall attach to IEC or its directors, employees, servants or agents including individual experts and members of its technical committees and IEC National Committees for any personal injury, property damage or other damage of any nature whatsoever, whether direct or indirect, or for costs (including legal fees) and expenses arising out of the publication, use of, or reliance upon, this IEC Publication or any other IEC Publications.
- 8) Attention is drawn to the Normative references cited in this publication. Use of the referenced publications is indispensable for the correct application of this publication.
- 9) Attention is drawn to the possibility that some of the elements of this IEC Publication may be the subject of patent rights. IEC shall not be held responsible for identifying any or all such patent rights.

International Standard IEC 60603-7 has been prepared by subcommittee 48B: Electrical connectors, of IEC technical committee 48: Electrical connectors and mechanical structures for electrical and electronic equipment.

This fourth edition cancels and replaces the third edition, published in 2008, its Amendment 1:2011 and its Amendment 2:2019. It constitutes a technical revision.

This edition includes the following significant technical change with respect to the previous edition:

- Revised the definitions for intermateability and interoperability; added new definitions.
- Corrected dimension line for dimension AZ2 in Figure 5.
- Corrected dimension line for dimension F1 in Figure A.1.
- Revised the reference to ISO/IEC 11801 to ISO/IEC 11801-1.

- Added lower limiting temperature and upper limiting temperature definitions.
- Revised Table 1 to Table 8 so the column order is Minimum-Nominal-Maximum dimensions (ascending order).
- Corrected Table 7: Climatic category and Upper temperature values to 90 °C (to be consistent with the graph in Figure 10 and Note 1 in Figure 10).
- Revised the wording in 8.2, contact resistance, for clarification.
- Revised Figure 11 and Figure 12 and the wording in the Key below for clarification.
- Removed the sentences under the figure in the Introduction.
- Added Annex E.

The text of this International Standard is based on the following documents:

FDIS	Report on voting
48B/2832/FDIS	8B/2843/RVD

Full information on the voting for the approval of this International Standard can be found in the report on voting indicated in the above table.

This document has been drafted in accordance with the ISO/IEC Directives, Part 2.

A list of all parts of IEC 60603-7 series, under the general title *Connectors for electronic equipment*, can be found on the IEC website.

The committee has decided that the contents of this document will remain unchanged until the stability date indicated on the IEC website under "<http://webstore.iec.ch>" in the data related to the specific document. At this date, the document will be

- reconfirmed,
- withdrawn,
- replaced by a revised edition, or
- amended.

IMPORTANT – The 'colour inside' logo on the cover page of this publication indicates that it contains colours which are considered to be useful for the correct understanding of its contents. Users should therefore print this document using a colour printer.

INTRODUCTION

IEC 60603-7 is the base specification of the whole series. Subsequent specifications do not duplicate information given in the base document, but list only additional requirements. For complete specifications regarding a component of a higher numbered document, all lower numbered documents must be considered as well. Figure 1 shows the interrelation of the documents.

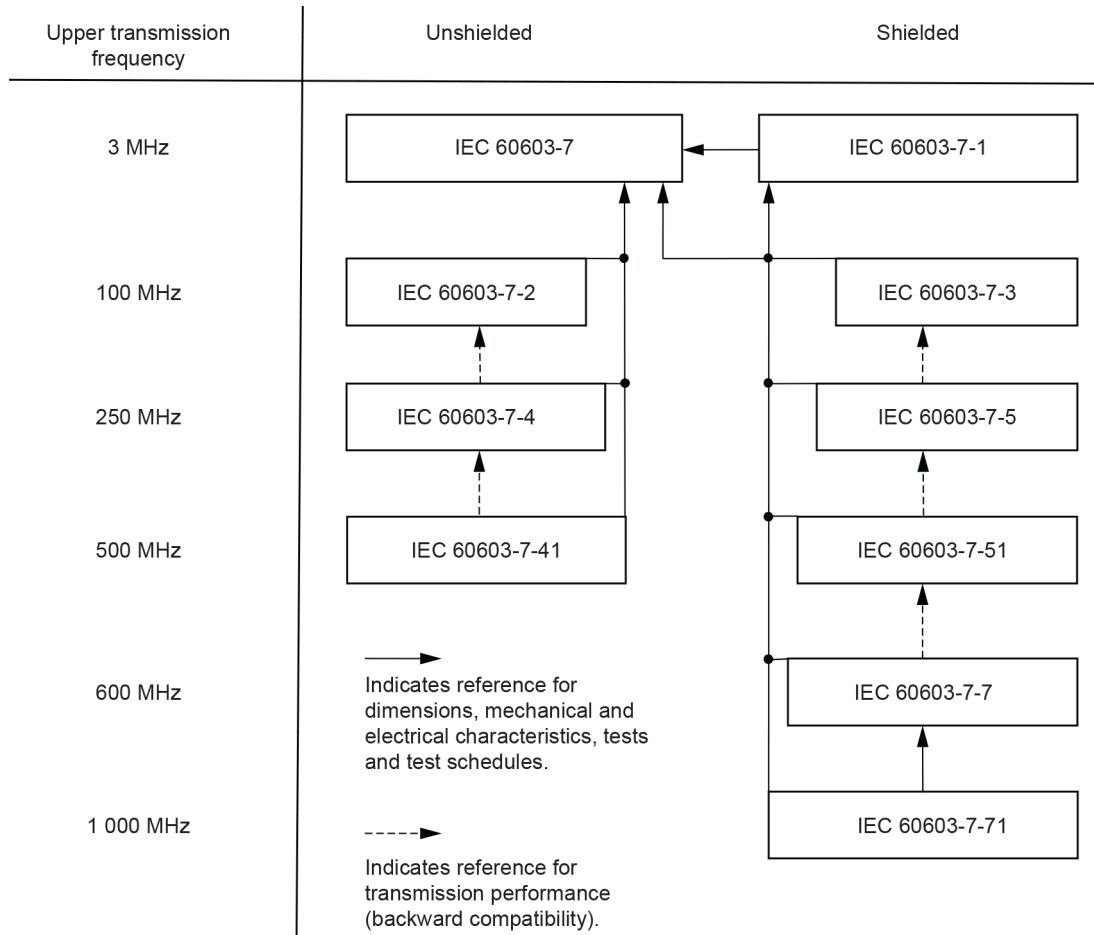

IEC

Figure 1 – IEC 60603-7 family document diagram

CONNECTORS FOR ELECTRONIC EQUIPMENT –

Part 7: Detail specification for 8-way, unshielded, free and fixed connectors

1 Scope

This part of IEC 60603-7 covers 8-way, unshielded, free and fixed connectors and is intended to specify the common dimensions (interface dimensions), mechanical, electrical and environmental characteristics and tests for the family of IEC 60603-7-x connectors.

These connectors are intermateable (according to IEC 61076-1 level 2) and interoperable with other IEC 60603-7 series connectors.

2 Normative references

The following documents are referred to in the text in such a way that some or all of their content constitutes requirements of this document. For dated references, only the edition cited applies. For undated references, the latest edition of the referenced document (including any amendments) applies.

IEC 60050-581:2008, *International Electrotechnical Vocabulary (IEV) – Part 581: Electromechanical components for electronic equipment*

IEC 60068-1, *Environmental testing – Part 1: General and guidance*

IEC 60068-2-38: *Environmental testing – Part 2-38: Tests – Test Z/AD: Composite temperature/humidity cyclic test*

IEC 60352-2, *Solderless connections – Part 2: Crimped connections – General requirements, test methods and practical guidance*

IEC 60352-3, *Solderless connections – Part 3: Accessible insulation displacement (ID) connections – General requirements, test methods and practical guidance*

IEC 60352-4, *Solderless connections – Part 4: Non-accessible insulation displacement (ID) connections – General requirements, test methods and practical guidance*

IEC 60352-5, *Solderless connections – Part 5: Press-in connections – General requirements, test methods and practical guidance*

IEC 60352-6, *Solderless connections – Part 6: Insulation piercing connections – General requirements, test methods and practical guidance*

IEC 60352-7, *Solderless connections – Part 7: Spring clamp connections – General requirements, test methods and practical guidance*

IEC 60512-1, *Connectors for electrical and electronic equipment – Tests and measurements – Part 1: Generic specification*

IEC 60512-1-1, *Connectors for electronic equipment – Tests and measurements – Part 1-1: General examination – Test 1a: Visual examination*

IEC 60512-1-2, *Connectors for electronic equipment – Tests and measurements – Part 1-2: General examination – Test 1b: Examination of dimensions and mass*

IEC 60512-1-100, *Connectors for electronic equipment – Tests and measurements – Part 1-100: General – Applicable publications*

IEC 60512-2-1, *Connectors for electronic equipment – Tests and measurements – Part 2-1: Electrical continuity and contact resistance tests – Test 2a: Contact resistance – Millivolt level method*

IEC 60512-2-5, *Connectors for electronic equipment – Tests and measurements – Part 2-5: Electrical continuity and contact resistance tests – Test 2e: Contact disturbance*

IEC 60512-3-1, *Connectors for electronic equipment – Tests and measurements – Part 3-1: Insulation tests – Test 3a: Insulation resistance*

IEC 60512-4-1, *Connectors for electronic equipment – Tests and measurements – Part 4-1: Voltage stress tests – Test 4a: Voltage proof*

IEC 60512-5-2, *Connectors for electronic equipment – Tests and measurements – Part 5-2: Current-carrying capacity tests – Test 5b: Current-temperature derating*

IEC 60512-6-4, *Connectors for electronic equipment – Tests and measurements – Part 6-4: Dynamic stress tests – Test 6d: Vibration (sinusoidal)*

IEC 60512-9-1, *Connectors for electronic equipment – Tests and measurements – Part 9-1: Endurance tests – Test 9a: Mechanical operation*

IEC 60512-9-2, *Connectors for electronic equipment – Tests and measurements – Part 9-2: Endurance tests – Test 9b: Electrical load and temperature*

IEC 60512-11-4, *Connectors for electronic equipment – Tests and measurements – Part 11-4: Climatic tests – Test 11d: Rapid change of temperature*

IEC 60512-11-7, *Connectors for electronic equipment – Tests and measurements – Part 11-7: Climatic tests – Test 11g: Flowing mixed gas corrosion test*

IEC 60512-13-2, *Connectors for electronic equipment – Tests and measurements – Part 13-2: Mechanical operation tests – Test 13b: Insertion and withdrawal forces*

IEC 60512-15-6, *Connectors for electronic equipment – Tests and measurements – Part 15-6: Connector tests (mechanical) – Test 15f: Effectiveness of connector coupling devices*

IEC 60603-7 (all parts), *Connectors for electronic equipment*

IEC 60664-1, *Insulation coordination for equipment within low-voltage systems – Part 1: Principles, requirements and tests*

IEC 61076-1:2006, *Connectors for electronic equipment – Product requirements – Part 1: Generic specification*

IEC 61076-3, *Connectors for electronic equipment – Product requirements – Part 3: Rectangular connectors – Sectional specification*

IEC 61156-2, *Multicore and symmetrical pair/quad cables for digital communications – Part 2: Symmetrical pair/quad cables with transmission characteristics up to 100 MHz – Horizontal floor wiring – Sectional specification*

IEC 61156-3, *Multicore and symmetrical pair/quad cables for digital communications – Part 3: Work area cable – Sectional specification*

IEC 61156-4, *Multicore and symmetrical pair/quad cables for digital communications – Part 4: Riser cables – Sectional specification*

IEC 61156-5, *Multicore and symmetrical pair/quad cables for digital communications – Part 5: Symmetrical pair/quad cables with transmission characteristics up to 1 000 MHz – Horizontal floor wiring – Sectional specification*

IEC 61156-6, *Multicore and symmetrical pair/quad cables for digital communications – Part 6: Symmetrical pair/quad cables with transmission characteristics up to 1 000 MHz – Work area wiring – Sectional specification*

IEC 61156-7, *Multicore and symmetrical pair/quad cables for digital communications – Part 7: Symmetrical pair cables with transmission characteristics up to 1 200 MHz – Sectional specification for digital and analog communication cables*

IEC 61760-3, *Surface mounting technology – Part 3: Standard method for the specification of components for through hole reflow (THR) soldering*

IEC TR 63040, *Guidance on clearances and creepage distances in particular for distances equal to or less than 2 mm – Test results of research on influencing parameters*

ISO/IEC 11801-1, *Information technology – Generic cabling for customer premises – Part 1: General requirements*

ISO 1302, *Geometrical Product Specifications (GPS) – Indication of surface texture in technical product documentation*

ITU-T Recommendation K.20:2000¹, *Resistibility of telecommunication equipment installed in a telecommunications centre to overvoltages and overcurrents*

ITU-T Recommendation K.44:2000², *Resistibility tests for telecommunication equipment exposed to overvoltages and overcurrents – Basic Recommendation*

koniec náhľadu – text ďalej pokračuje v platenej verzii STN