

STN	Jadrové zariadenia Elektrická sústava Všeobecné požiadavky	STN EN IEC 63046 35 6605
------------	---	--

Nuclear power plants - Electrical power system - General requirements

Táto norma obsahuje anglickú verziu európskej normy.
This standard includes the English version of the European Standard.

Táto norma bola oznámená vo Vestníku ÚNMS SR č. 08/21

Obsahuje: EN IEC 63046:2021, IEC 63046:2020

133231

EUROPEAN STANDARD

EN IEC 63046

NORME EUROPÉENNE

EUROPÄISCHE NORM

May 2021

ICS 27.120.20

English Version

**Nuclear power plants - Electrical power system - General requirements
(IEC 63046:2020)**

Centrales nucléaires de puissance - Système d'alimentation électrique - Exigences générales
(IEC 63046:2020)

Kernkraftwerke - Elektrische Stromversorgungssysteme - Allgemeine Anforderungen
(IEC 63046:2020)

This European Standard was approved by CENELEC on 2021-05-17. CENELEC members are bound to comply with the CEN/CENELEC Internal Regulations which stipulate the conditions for giving this European Standard the status of a national standard without any alteration.

Up-to-date lists and bibliographical references concerning such national standards may be obtained on application to the CEN-CENELEC Management Centre or to any CENELEC member.

This European Standard exists in three official versions (English, French, German). A version in any other language made by translation under the responsibility of a CENELEC member into its own language and notified to the CEN-CENELEC Management Centre has the same status as the official versions.

CENELEC members are the national electrotechnical committees of Austria, Belgium, Bulgaria, Croatia, Cyprus, the Czech Republic, Denmark, Estonia, Finland, France, Germany, Greece, Hungary, Iceland, Ireland, Italy, Latvia, Lithuania, Luxembourg, Malta, the Netherlands, Norway, Poland, Portugal, Republic of North Macedonia, Romania, Serbia, Slovakia, Slovenia, Spain, Sweden, Switzerland, Turkey and the United Kingdom.



European Committee for Electrotechnical Standardization
Comité Européen de Normalisation Electrotechnique
Europäisches Komitee für Elektrotechnische Normung

CEN-CENELEC Management Centre: Rue de la Science 23, B-1040 Brussels

EN IEC 63046:2021 (E)**European foreword**

The text of document 45A/1348/FDIS, future edition 1 of IEC 63046, prepared by SC 45A "Instrumentation, control and electrical power systems of nuclear facilities" of IEC/TC 45 "Nuclear instrumentation" was submitted to the IEC-CENELEC parallel vote and approved by CENELEC as EN IEC 63046:2021.

The following dates are fixed:

- latest date by which the document has to be implemented at national level by publication of an identical national standard or by endorsement (dop) 2022-02-17
- latest date by which the national standards conflicting with the document have to be withdrawn (dow) 2024-05-17

Attention is drawn to the possibility that some of the elements of this document may be the subject of patent rights. CENELEC shall not be held responsible for identifying any or all such patent rights.

As stated in the nuclear safety directive 2009/71/EURATOM, Chapter 1, Article 2, item 2, Member States are not prevented from taking more stringent safety measures in the subject-matter covered by the Directive, in compliance with Community law.

In a similar manner, this European standard does not prevent Member States from taking more stringent nuclear safety and/or security measures in the subject-matter covered by this standard.

Endorsement notice

The text of the International Standard IEC 63046:2020 was approved by CENELEC as a European Standard without any modification.

In the official version, for Bibliography, the following notes have to be added for the standards indicated:

IEC 60364-5-52	NOTE	Harmonized as HD 60364-5-52
IEC 60880	NOTE	Harmonized as EN 60880
IEC 61508-1	NOTE	Harmonized as EN 61508-1
IEC 61508-2	NOTE	Harmonized as EN 61508-2
IEC 61508-3	NOTE	Harmonized as EN 61508-3
IEC 61508-4	NOTE	Harmonized as EN 61508-4
IEC 62003	NOTE	Harmonized as EN IEC 62003
IEC 62040-3	NOTE	Harmonized as EN 62040-3
IEC 62138	NOTE	Harmonized as EN IEC 62138
IEC 62271-200	NOTE	Harmonized as EN 62271-200
IEC 62305-1	NOTE	Harmonized as EN 62305-1
IEC 62305-3	NOTE	Harmonized as EN 62305-3
IEC 62305-4	NOTE	Harmonized as EN 62305-4
IEC 62340	NOTE	Harmonized as EN 62340
IEC 62566	NOTE	Harmonized as EN 62566
IEC 62645	NOTE	Harmonized as EN IEC 62645
ISO/IEC 27001	NOTE	Harmonized as EN ISO/IEC 27001
ISO/IEC 27002	NOTE	Harmonized as EN ISO/IEC 27002
ISO 9000	NOTE	Harmonized as EN ISO 9000

Annex ZA (normative)

Normative references to international publications with their corresponding European publications

The following documents are referred to in the text in such a way that some or all of their content constitutes requirements of this document. For dated references, only the edition cited applies. For undated references, the latest edition of the referenced document (including any amendments) applies.

NOTE 1 Where an International Publication has been modified by common modifications, indicated by (mod), the relevant EN/HD applies.

NOTE 2 Up-to-date information on the latest versions of the European Standards listed in this annex is available here: www.cenelec.eu.

<u>Publication</u>	<u>Year</u>	<u>Title</u>	<u>EN/HD</u>	<u>Year</u>
IEC 60038 (mod)	2009	IEC standard voltages	EN 60038	2011
IEC 60671	-	Nuclear power plants - Instrumentation and control systems important to safety - Surveillance testing	EN 60671	-
IEC 60709	2018	Nuclear power plants - Instrumentation, control and electrical power systems important to safety - Separation	EN IEC 60709	2019
IEC 60964	2018	Nuclear power plants - Control rooms Design	EN IEC 60964	2019
IEC 61225	-	Nuclear power plants - Instrumentation, control and electrical power systems - Requirements for static uninterruptible DC and AC power supply systems	+EN 60964:2019/AC:2019-08 EN IEC 61225	IEC 2019
IEC 61226	-	Nuclear power plants - Instrumentation and control important to safety - Classification of instrumentation and control functions	EN 61226	-
IEC 61513	2011	Nuclear power plants - Instrumentation and control important to safety - General requirements for systems	EN 61513	2013
IEC 62671	-	Nuclear power plants - Instrumentation and control important to safety - Selection and use of industrial digital devices of limited functionality	-	-
IEC 62808	-	Nuclear power plants - Instrumentation and control systems important to safety - Design and qualification of isolation devices	EN 62808	-
IEC 62855	2016	Nuclear power plants - Electrical power systems - Electrical power systems analysis	prEN IEC 62855	2021

EN IEC 63046:2021 (E)

<u>Publication</u>	<u>Year</u>	<u>Title</u>	<u>EN/HD</u>	<u>Year</u>
IEC 62859	-	Nuclear power plants - Instrumentation and control systems - Requirements for coordinating safety and cybersecurity	EN 62859	-
ISO 9001		Quality management systems Requirements	-EN ISO 9001	2015
IEC/IEEE 323	60780--	Nuclear facilities - Electrical equipment important to safety - Qualification	EN 60780-323	-
IEC/IEEE 344	60980--	Nuclear facilities - Equipment important to safety - Seismic qualification	EN IEC/IEEE-60980-344	



IEC 63046

Edition 1.0 2020-10

INTERNATIONAL STANDARD

NORME INTERNATIONALE



Nuclear power plants – Electrical power system – General requirements

**Centrales nucléaires de puissance – Système d'alimentation électrique –
Exigences générales**



THIS PUBLICATION IS COPYRIGHT PROTECTED
Copyright © 2020 IEC, Geneva, Switzerland

All rights reserved. Unless otherwise specified, no part of this publication may be reproduced or utilized in any form or by any means, electronic or mechanical, including photocopying and microfilm, without permission in writing from either IEC or IEC's member National Committee in the country of the requester. If you have any questions about IEC copyright or have an enquiry about obtaining additional rights to this publication, please contact the address below or your local IEC member National Committee for further information.

Droits de reproduction réservés. Sauf indication contraire, aucune partie de cette publication ne peut être reproduite ni utilisée sous quelque forme que ce soit et par aucun procédé, électronique ou mécanique, y compris la photocopie et les microfilms, sans l'accord écrit de l'IEC ou du Comité national de l'IEC du pays du demandeur. Si vous avez des questions sur le copyright de l'IEC ou si vous désirez obtenir des droits supplémentaires sur cette publication, utilisez les coordonnées ci-après ou contactez le Comité national de l'IEC de votre pays de résidence.

IEC Central Office
 3, rue de Varembe
 CH-1211 Geneva 20
 Switzerland

Tel.: +41 22 919 02 11
info@iec.ch
www.iec.ch

About the IEC

The International Electrotechnical Commission (IEC) is the leading global organization that prepares and publishes International Standards for all electrical, electronic and related technologies.

About IEC publications

The technical content of IEC publications is kept under constant review by the IEC. Please make sure that you have the latest edition, a corrigendum or an amendment might have been published.

IEC publications search - webstore.iec.ch/advsearchform

The advanced search enables to find IEC publications by a variety of criteria (reference number, text, technical committee,...). It also gives information on projects, replaced and withdrawn publications.

IEC Just Published - webstore.iec.ch/justpublished

Stay up to date on all new IEC publications. Just Published details all new publications released. Available online and once a month by email.

IEC Customer Service Centre - webstore.iec.ch/csc

If you wish to give us your feedback on this publication or need further assistance, please contact the Customer Service Centre: sales@iec.ch.

Electropedia - www.electropedia.org

The world's leading online dictionary on electrotechnology, containing more than 22 000 terminological entries in English and French, with equivalent terms in 16 additional languages. Also known as the International Electrotechnical Vocabulary (IEV) online.

IEC Glossary - std.iec.ch/glossary

67 000 electrotechnical terminology entries in English and French extracted from the Terms and Definitions clause of IEC publications issued since 2002. Some entries have been collected from earlier publications of IEC TC 37, 77, 86 and CISPR.

A propos de l'IEC

La Commission Electrotechnique Internationale (IEC) est la première organisation mondiale qui élabore et publie des Normes internationales pour tout ce qui a trait à l'électricité, à l'électronique et aux technologies apparentées.

A propos des publications IEC

Le contenu technique des publications IEC est constamment revu. Veuillez vous assurer que vous possédez l'édition la plus récente, un corrigendum ou amendement peut avoir été publié.

Recherche de publications IEC -

webstore.iec.ch/advsearchform

La recherche avancée permet de trouver des publications IEC en utilisant différents critères (numéro de référence, texte, comité d'études,...). Elle donne aussi des informations sur les projets et les publications remplacées ou retirées.

IEC Just Published - webstore.iec.ch/justpublished

Restez informé sur les nouvelles publications IEC. Just Published détaille les nouvelles publications parues. Disponible en ligne et une fois par mois par email.

Service Clients - webstore.iec.ch/csc

Si vous désirez nous donner des commentaires sur cette publication ou si vous avez des questions contactez-nous: sales@iec.ch.

Electropedia - www.electropedia.org

Le premier dictionnaire d'électrotechnologie en ligne au monde, avec plus de 22 000 articles terminologiques en anglais et en français, ainsi que les termes équivalents dans 16 langues additionnelles. Egalement appelé Vocabulaire Electrotechnique International (IEV) en ligne.

Glossaire IEC - std.iec.ch/glossary

67 000 entrées terminologiques électrotechniques, en anglais et en français, extraites des articles Termes et Définitions des publications IEC parues depuis 2002. Plus certaines entrées antérieures extraites des publications des CE 37, 77, 86 et CISPR de l'IEC.



IEC 63046

Edition 1.0 2020-10

INTERNATIONAL STANDARD

NORME INTERNATIONALE



Nuclear power plants – Electrical power system – General requirements

**Centrales nucléaires de puissance – Système d'alimentation électrique –
Exigences générales**

INTERNATIONAL
ELECTROTECHNICAL
COMMISSION

COMMISSION
ELECTROTECHNIQUE
INTERNATIONALE

ICS 27.120.20

ISBN 978-2-8322-8817-7

**Warning! Make sure that you obtained this publication from an authorized distributor.
Attention! Veuillez vous assurer que vous avez obtenu cette publication via un distributeur agréé.**

CONTENTS

FOREWORD.....	5
INTRODUCTION.....	7
1 Scope.....	9
1.1 General.....	9
1.2 Application: new and pre-existing plants	11
1.3 Framework.....	11
1.4 Interaction with level 2 standards	11
2 Normative references	13
3 Terms and definitions	14
4 Abbreviated terms	23
5 Overall Electrical Power System life cycle	24
6 Architecture of Electrical Power System: identification of requirements.....	25
6.1 Objectives.....	25
6.2 Safety requirements applicable to the electrical architecture design.....	26
6.2.1 Defence in Depth.....	26
6.2.2 Application of Single Failure Criterion	26
6.2.3 Management of the Common Cause Failure	26
6.2.4 Loss Of Off-site Power conditions	26
6.2.5 Station Black Out conditions	27
6.2.6 Loss of Electrical Power conditions.....	27
6.2.7 Application of internal and external Hazards	27
6.2.8 Nuclear security requirements	28
6.2.9 Classification requirements.....	28
6.2.10 Probabilistic requirements	28
6.3 Electrical requirements	28
6.3.1 Requirements coordinated with the electric grid operator.....	28
6.3.2 Electrical disturbances.....	29
6.4 Functional performance requirements	29
6.5 Maintenance requirements.....	30
7 Design of the electrical architecture.....	30
7.1 Objectives.....	30
7.2 Safety design provision.....	30
7.2.1 Defence in Depth in the Electrical Power System.....	30
7.2.2 Single Failure in the Electrical Power System	31
7.2.3 Common Cause Failure in the Electrical Power System	31
7.2.4 Provisions for coping with Loss Of Off-site Power	37
7.2.5 Provisions for coping with Station Black Out	38
7.2.6 Provisions to avoid or reduce Loss of Electrical Power	38
7.2.7 Classification consideration	38
7.2.8 Provisions to achieve the reliability target for the Electrical Power System	39
7.3 Electrical design provision	40
7.3.1 General	40
7.3.2 Coordination with the grid.....	40
7.3.3 Design to achieve electrical requirements.....	40
7.4 Functional and performance design provisions.....	46
7.4.1 General	46

7.4.2	Electrical Power System studies	46
7.4.3	Design of the Interruptible Power Supply System.....	49
7.4.4	Design of the Uninterruptible Power Supply System	49
7.5	Maintenance	50
7.5.1	Consideration of the maintenance in the electrical design.....	50
7.6	Multi-unit shared electrical power systems	51
7.7	Electrical system layout	51
7.8	Supporting and associated systems for the Electrical Power System	51
7.9	Overall quality assurance programs	52
7.10	Requirements for output documentation.....	53
7.10.1	General	53
7.10.2	Architecture principles	54
7.10.3	Single line diagrams	55
8	Sub-system requirements	55
8.1	Electrical Power System basis requirements	55
8.1.1	General	55
8.1.2	System Design	56
8.1.3	Single line diagram	56
8.2	Equipment design specification	56
8.3	Equipment requirements	56
8.4	AC Interruptible Electrical Power Supply System	56
8.5	AC/DC Uninterruptible Power Supply System.....	57
8.6	Coordination and interaction with power grid.....	57
8.7	Earthing	57
9	Verification of the architecture of the Electrical Power System.....	57
9.1	General.....	57
9.2	Computerised tools and models verification	57
9.2.1	Electrical Power System verification	57
9.2.2	Layout of electrical power systems and equipment verification	57
9.3	Test requirements	58
10	Overall integration and commissioning	59
10.1	General.....	59
10.2	Requirements	59
10.3	Output documentation.....	60
11	Overall operation and maintenance	60
11.1	General.....	60
11.2	Requirements	60
11.3	Output documentation.....	60
12	System quality assurance plan	61
12.1	General.....	61
12.2	System verification plan	61
12.3	System configuration management plan.....	62
12.4	Fault resolution procedures.....	62
Annex A (informative)	Basic safety issues in NPPs	63
A.1	General.....	63
A.2	Plant safety objectives	63
A.3	Plant safety analysis	63
A.3.1	General	63

A.3.2	Analysis of event sequences	64
A.3.3	Assessment of design basis: deterministic/probabilistic methods	64
A.4	Defence in Depth	64
Annex B (informative)	AC Interruptible Electrical Power System	67
B.1	General.....	67
B.2	Electrical design provisions.....	67
B.2.1	Steady state conditions for Electrical Power System.....	67
B.2.2	Electrical disturbances.....	68
B.3	Design of the Interruptible power system	71
B.3.1	Design of the preferred power supply	71
B.3.2	Design of the off-site power supply	71
B.3.3	Design of on-site preferred power supply.....	72
B.3.4	Design of the AC interruptible power systems important to safety	72
B.3.5	Design of internal standby sources	72
B.4	Preferred power supply system (from IAEA SSG 34:2016, chapter 6, clauses 6.1 to 6.44)	73
B.4.1	General	73
B.4.2	Operation	73
B.4.3	Grid interface and agreement with grid operator	73
B.4.4	Reliability of the preferred power supply	73
B.4.5	Off-site power supplies	74
B.4.6	Availability	75
B.4.7	Independence of off-site circuits	75
B.4.8	Switchyard.....	76
B.5	Safety power supply system supporting DBC	76
B.5.1	General	76
B.5.2	Design (from IAEA SSG 34:2016, chapter 7, clauses 7.36 to 7.63)	77
B.5.3	Testing (from IAEA SSG 34:2016, chapter 7, clauses 7.64 to 7.67).....	79
B.5.4	Performance criteria (transient and dynamic) (from IAEA SSG 34:2016, chapter 7, clauses 7.68 to 7.70).....	79
B.5.5	Relay protection of standby power sources (from IAEA SSG 34:2016, chapter 7, clauses 7.71 to 7.75).....	79
B.5.6	Support systems for standby AC power sources	80
B.5.7	Fuel for standby AC power sources	80
B.6	Power supply system important to safety supporting DEC	80
B.6.1	General	80
B.6.2	Design (from IAEA SSG 34:2016, chapter 8, clauses 8.1 to 8.18)	81
B.7	Mobile sources connections network.....	82
B.8	Monitoring and switching of buses	82
Annex C (informative)	Earthing	84
Annex D (informative)	Logic diagram followed for the design of the EPS.....	85
Bibliography.....		86
Figure 1 – Scope of work of this document.....		10
Figure 2 – Architecture of Electrical Power System		12
Figure 3 – Connections between the overall Electrical Power System life cycle and the life cycles of the electrical power sub- systems		25
Figure 4 – Typical voltage design bases (IEC 62855).....		43
Table A.1 – Support of the electrical power supply for the defence in depth of the plant		66

INTERNATIONAL ELECTROTECHNICAL COMMISSION

**NUCLEAR POWER PLANTS –
ELECTRICAL POWER SYSTEM –
GENERAL REQUIREMENTS**
FOREWORD

- 1) The International Electrotechnical Commission (IEC) is a worldwide organization for standardization comprising all national electrotechnical committees (IEC National Committees). The object of IEC is to promote international co-operation on all questions concerning standardization in the electrical and electronic fields. To this end and in addition to other activities, IEC publishes International Standards, Technical Specifications, Technical Reports, Publicly Available Specifications (PAS) and Guides (hereafter referred to as "IEC Publication(s)"). Their preparation is entrusted to technical committees; any IEC National Committee interested in the subject dealt with may participate in this preparatory work. International, governmental and non-governmental organizations liaising with the IEC also participate in this preparation. IEC collaborates closely with the International Organization for Standardization (ISO) in accordance with conditions determined by agreement between the two organizations.
- 2) The formal decisions or agreements of IEC on technical matters express, as nearly as possible, an international consensus of opinion on the relevant subjects since each technical committee has representation from all interested IEC National Committees.
- 3) IEC Publications have the form of recommendations for international use and are accepted by IEC National Committees in that sense. While all reasonable efforts are made to ensure that the technical content of IEC Publications is accurate, IEC cannot be held responsible for the way in which they are used or for any misinterpretation by any end user.
- 4) In order to promote international uniformity, IEC National Committees undertake to apply IEC Publications transparently to the maximum extent possible in their national and regional publications. Any divergence between any IEC Publication and the corresponding national or regional publication shall be clearly indicated in the latter.
- 5) IEC itself does not provide any attestation of conformity. Independent certification bodies provide conformity assessment services and, in some areas, access to IEC marks of conformity. IEC is not responsible for any services carried out by independent certification bodies.
- 6) All users should ensure that they have the latest edition of this publication.
- 7) No liability shall attach to IEC or its directors, employees, servants or agents including individual experts and members of its technical committees and IEC National Committees for any personal injury, property damage or other damage of any nature whatsoever, whether direct or indirect, or for costs (including legal fees) and expenses arising out of the publication, use of, or reliance upon, this IEC Publication or any other IEC Publications.
- 8) Attention is drawn to the Normative references cited in this publication. Use of the referenced publications is indispensable for the correct application of this publication.
- 9) Attention is drawn to the possibility that some of the elements of this IEC Publication may be the subject of patent rights. IEC shall not be held responsible for identifying any or all such patent rights.

International Standard IEC 63046 has been prepared by subcommittee 45A: Instrumentation, control and electrical power systems of nuclear facilities, of IEC technical committee 45: Nuclear instrumentation.

The text of this International Standard is based on the following documents:

FDIS	Report on voting
45A/1348/FDIS	45A/1355/RVD

Full information on the voting for the approval of this International Standard can be found in the report on voting indicated in the above table.

This document has been drafted in accordance with the ISO/IEC Directives, Part 2.

The committee has decided that the contents of this document will remain unchanged until the stability date indicated on the IEC website under "<http://webstore.iec.ch>" in the data related to the specific document. At this date, the document will be

- reconfirmed,
- withdrawn,
- replaced by a revised edition, or
- amended.

IMPORTANT – The 'colour inside' logo on the cover page of this publication indicates that it contains colours which are considered to be useful for the correct understanding of its contents. Users should therefore print this document using a colour printer.

INTRODUCTION

a) Technical background, main issues, and organisation of the Standard

The purpose of this standard is to provide the high level specification and requirement to implement a suitable Electrical Power System in a Nuclear Power Plant (NPP).

The electric power system in NPPs supports reactor systems important to safety. It also allows electric energy production providing the transmission grid with active and reactive power and electro-mechanical inertia.

The designers, operators of NPPs (utilities), equipment suppliers, systems evaluators and licensors, may use this document.

b) Situation of the current Standard in the structure of the IEC SC 45A standard series

The entry point of the IEC SC 45A standard series should be summary report introducing the two first level standards for I&C (IEC 61513) and the Electrical Power System (IEC 63046).

This document is the first level IEC SC 45A document tackling the issue of general requirements for Electrical Power System and sub-systems.

For more details on the structure of the IEC SC 45A standard series, see item d) of this introduction.

c) Recommendations and limitations regarding the application of this Standard

It is important to note that this Standard establishes no additional functional requirements for safety systems.

To ensure that the Standard will continue to be relevant in future years, the emphasis has been placed on issues of principle, rather than specific technologies.

d) Description of the structure of the IEC SC 45A standard series and relationships with other IEC documents and other bodies documents (IAEA, ISO)

The top-level documents of the IEC SC 45A standard series are IEC 61513 and IEC 63046. IEC 61513 provides general requirements for I&C systems and equipment that are used to perform functions important to safety in NPPs. IEC 63046 provides general requirements for electrical power systems of NPPs; it covers power supply systems including the supply systems of the I&C systems. IEC 61513 and IEC 63046 are to be considered in conjunction and at the same level. IEC 61513 and IEC 63046 structure the IEC SC 45A standard series and shape a complete framework establishing general requirements for instrumentation, control and electrical systems for nuclear power plants.

IEC 61513 and IEC 63046 refer directly to other IEC SC 45A standards for general topics related to categorization of functions and classification of systems, qualification, separation, defence against common cause failure, control room design, electromagnetic compatibility, cybersecurity, software and hardware aspects for programmable digital systems, coordination of safety and security requirements and management of ageing. The standards referenced directly at this second level should be considered together with IEC 61513 and IEC 63046 as a consistent document set.

At a third level, IEC SC 45A standards not directly referenced by IEC 61513 or by IEC 63046 are standards related to specific equipment, technical methods, or specific activities. Usually these documents, which make reference to second-level documents for general topics, can be used on their own.

A fourth level extending the IEC SC 45 standard series, corresponds to the Technical Reports which are not normative.

The IEC SC 45A standards series consistently implements and details the safety and security principles and basic aspects provided in the relevant IAEA safety standards and in the relevant documents of the IAEA nuclear security series (NSS). In particular this includes the IAEA requirements SSR-2/1, establishing safety requirements related to the design of nuclear power plants (NPPs), the IAEA safety guide SSG-30 dealing with the safety classification of structures, systems and components in NPPs, the IAEA safety guide SSG-39 dealing with the design of instrumentation and control systems for NPPs, the IAEA safety guide SSG-34 dealing with the design of electrical power systems for NPPs and the implementing guide NSS17 for computer security at nuclear facilities. The safety and security terminology and definitions used by SC 45A standards are consistent with those used by the IAEA.

IEC 61513 and IEC 63046 have adopted a presentation format similar to the basic safety publication IEC 61508 with an overall life-cycle framework and a system life-cycle framework. Regarding nuclear safety, IEC 61513 and IEC 63046 provide the interpretation of the general requirements of IEC 61508-1, IEC 61508-2 and IEC 61508-4, for the nuclear application sector. In this framework IEC 60880, IEC 62138 and IEC 62566 correspond to IEC 61508-3 for the nuclear application sector.

IEC 61513 and IEC 63046 refer to ISO as well as to IAEA GS-R part 2 and IAEA GS-G-3.1 and IAEA GS-G-3.5 for topics related to quality assurance (QA).

At level 2, regarding nuclear security, IEC 62645 is the entry document for the IEC/SC 45A security standards. It builds upon the valid high level principles and main concepts of the generic security standards, in particular ISO/IEC 27001 and ISO/IEC 27002; it adapts them and completes them to fit the nuclear context and coordinates with the IEC 62443 series. At level 2, IEC 60964 is the entry document for the IEC/SC 45A control rooms standards and IEC 62342 is the entry document for the ageing management standards.

NOTE 1 It is assumed that for the design of I&C systems in NPPs that implement conventional safety functions (e.g. to address worker safety, asset protection, chemical hazards, process energy hazards) international or national standards would be applied.

NOTE 2 IEC/SC 45A domain was extended in 2013 to cover electrical systems. In 2014 and 2015 discussions were held in IEC/SC 45A to decide how and where general requirements for the design of electrical systems were to be considered. IEC/SC 45A experts recommended that an independent standard be developed at the same level as IEC 61513 to establish general requirements for electrical systems. Project IEC 63046 was launched to cover this objective. As IEC 63046 is published, from now on this Note 2 of the introduction of IEC/SC 45A standards will not be included in the newly published standards.

NUCLEAR POWER PLANTS – ELECTRICAL POWER SYSTEM – GENERAL REQUIREMENTS

1 Scope

1.1 General

This document:

- provides requirements and recommendations for the overall Electrical Power System. In particular, it covers interruptible and uninterruptible Electrical Power Systems including the systems supplying the I&C systems;
- is consistent and coherent with IEC 61513. Like IEC 61513, this document also highlights the need for complete and precise requirements, derived from the plant safety goals. Those requirements are prerequisites for generating the comprehensive requirements for the overall Electrical Power System architecture, and for the electrical power supply sub-systems;
- has to be considered in conjunction with and at the same level as IEC 61513. These two standards provide a complete framework establishing general requirements for instrumentation, control, and Electrical Power System for Nuclear Power Plants.

This document establishes:

- the high level specification and requirement to implement a suitable Electrical Power System in a NPP that supports reactor systems important to safety. It also enables electrical energy production providing the transmission grid with active and reactive power and electro-mechanical inertia;
- the relationships between:
 - the plant safety requirements and the architecture of the overall Electrical Power System and its sub-systems (see Figure 1) including:
 - a) the contribution to the plant Defence in Depth;
 - b) the independency and redundancy provisions;
 - the electrical requirements and the architecture of the Electrical Power System and its sub-systems;
 - the functional requirements and the architecture of the Electrical Power System and its sub-systems;
 - the requirements associated with the maintenance strategy and the architecture of the Electrical Power System and its sub-systems;
- the design of Electrical power sub-systems (e.g. interruptible and uninterruptible);
- the requirements for supporting systems of Electrical Power System (HVAC, I&C, etc.);
- the Electrical Power System life-cycle framework.

This document does not cover the specification of:

- I&C systems;
- the transmission lines connecting to substations outside the NPP;
- electrical equipment requirements already defined in the industrial IEC standards;
- electrical power for security systems (e.g., fences, surveillance systems, entrance control);

- lighting and socket facility.

This document does not consider power production requirements.

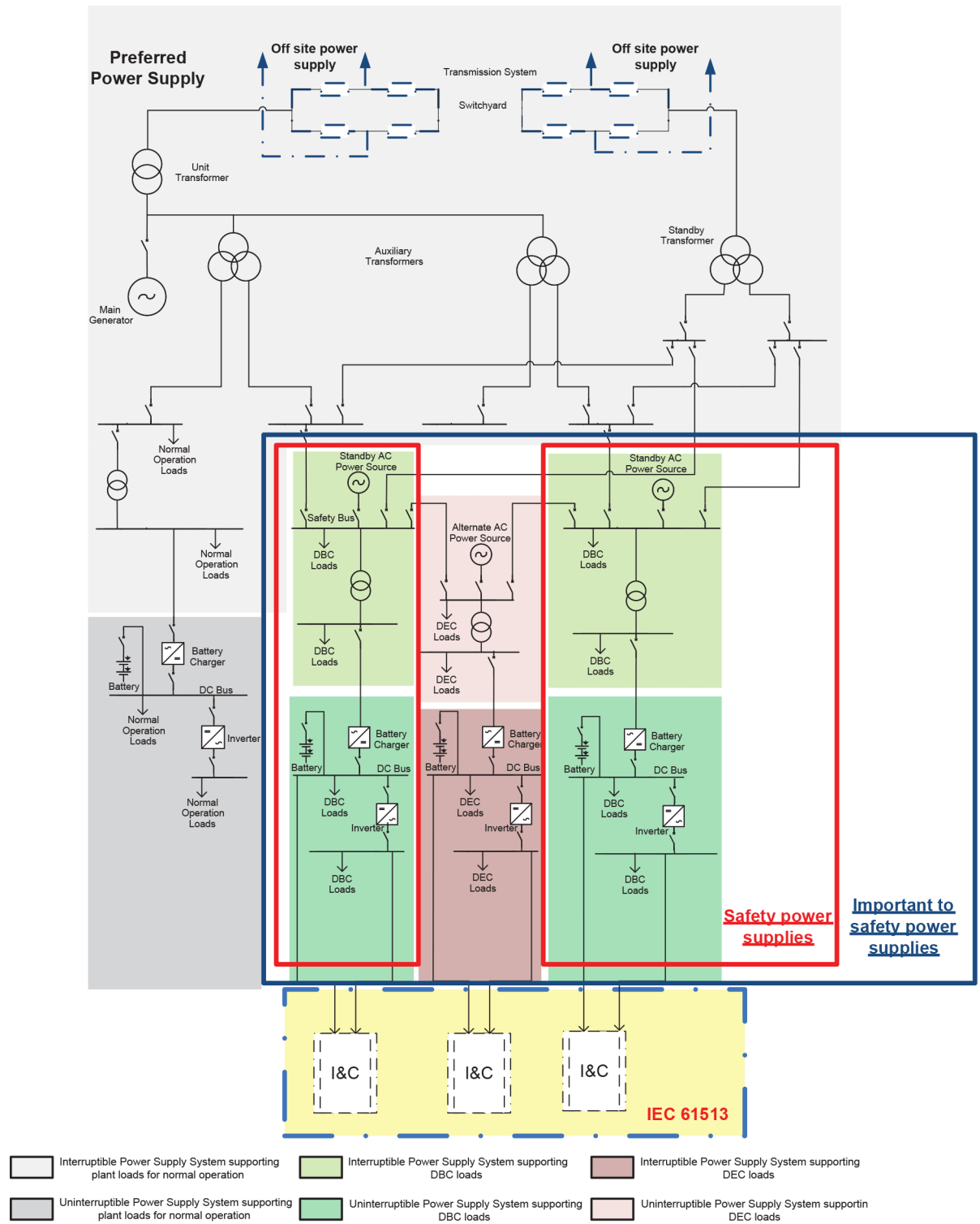

IEC

Figure 1 – Scope of work of this document

NOTE Figure 1 is based on IAEA SSG34:2016, Figure 3, with adaptation regarding the scope.

This figure provides only an example. Various possible arrangements of buses, loads, generators and interconnections would meet the requirements of SSR-2/1. Furthermore, many elements of the plant system, such as buses that are not important to safety and direct current power systems, are not shown. This figure is intended only to represent the relationship between the elements of the plant power systems that are within the safety classification and the preferred power supply. The elements of the preferred power supply that are not within the bounds of the important to safety power supply are outside the scope of the plant safety classification. The system elements included in the important to safety power supplies will differ according to plant design and the classification methods applied in different States. The classification methods are held by IEC 61226. Some plant designs may not require safety standby power sources. All nuclear power plants are expected to have safety direct current power supplies.

1.2 Application: new and pre-existing plants

This document is applicable to the Electrical Power System of new nuclear power plants and upgrading or back fitting of existing plants.

For existing plants, only a subset of requirements may be applicable and this subset should be identified at the beginning of any project.

1.3 Framework

This document consists of six normative clauses (an overview is provided in Figure 2):

- Clause 6 addresses the identification of requirements;
- Clause 7 addresses the design of the electrical architecture;
- Clause 8 addresses the sub-system requirements;
- Clause 9 addresses the verification;
- Clause 10 addresses the overall integration and commissioning;
- Clause 11 addresses the overall operation and maintenance.

1.4 Interaction with level 2 standards

This document shall permit an electrical designer to establish the list of requirements applicable for the design.

It also provides the different provisions applicable for the different requirements.

These provisions will be applied to the different type of power networks (sub-system):

- interruptible AC power network;
- uninterruptible power network.

Moreover, other transverse level 2 standards will define requirements applicable to electrical architecture definition.

The nuclear standards linked with the safety provisions (such as safety classification, separation, qualification or surveillance testing, etc.) are considered as input data for this document.

6 Architecture of Electrical Power System: Identification of requirements		
6.2 Safety requirements	6.3 Electrical requirements	
6.2.1 Defence in Depth	6.3.1 Requirements coordinated with the electric grid operator	
6.2.2 Application of Single Failure Criterion	6.3.2 Electrical disturbances	
6.2.3 Management of the Common Cause Failure		
6.2.4 Loss Of Off-site Power conditions	6.4 Functional, performance requirements	
6.2.5 Station Black Out conditions	6.5 Maintenance requirements	
6.2.6 Loss of Electrical power conditions		
6.2.7 Application of internal and external Hazards		
6.2.8 Nuclear security requirements		
6.2.9 Classification requirements		
6.2.10 Probabilistic requirements		
7 Overall Architecture of Electrical Power System and structured approach: Design of the electrical architecture		
7.2 Safety design provision	7.3 Electrical design provision	7.6 Multi-unit shared electrical power systems
7.2.1 Defence in Depth in the Electrical Power System	7.3.2 Coordination with the grid	
7.2.2 SF in the Electrical Power System	7.3.3 Design to achieve electrical requirements	7.7 Electrical system layout
7.2.3 CCF in the Electrical Power System	7.4 Functional and performance design provisions	7.8 Supporting and associated systems for the EPS
7.2.4 Provisions for coping with LOOP	7.4.2 Electrical Power System studies	
7.2.5 Provisions for coping with SBO	7.4.3 Design of the Interruptible Power Supply System	7.9 Overall quality assurance programs
7.2.6 Provisions to avoid or reduce Loss of Electrical Power	7.4.4 Design of the Uninterruptible Power Supply System	
7.2.7 Classification consideration		7.10 Requirements for output documentation
7.2.7.2 Qualification	7.5 Maintenance	
7.2.7.3 Surveillance Testing	7.5.1 Consideration of the maintenance in the electrical design	
7.2.8 Provisions to achieve the reliability target for the Electrical Power System		
8 Sub-System requirements		
8.1 Electrical Power System basis requirements	8.4 AC Interruptible Electrical Power Supply System	8.6 Coordination and interaction with the grid
8.2 Equipment design specification	8.5 AC/DC Uninterruptible Power Supply System	8.7 Earthing
8.3 Equipment requirements		
9 Verification of the architecture of the Electrical Power System		
9.2 Computerised tools and models verification	9.3 Test requirements	
10 Overall integration and commissioning		
10.2 Requirements	10.3 Output documentation	
11 Overall operation and maintenance		
11.2 Requirements	11.3 Output documentation	
12 System quality assurance plan		
12.2 System verification plan	12.3 System configuration management plan	12.4 Fault resolution procedures

Figure 2 – Architecture of Electrical Power System

2 Normative references

The following documents are referred to in the text in such a way that some or all of their content constitutes requirements of this document. For dated references, only the edition cited applies. For undated references, the latest edition of the referenced document (including any amendments) applies.

IEC 60038:2009, *IEC standard voltages*

IEC 60671, *Nuclear power plants – Instrumentation and control systems important to safety – Surveillance testing*

IEC 60709:2018, *Nuclear power plants – Instrumentation, control and electrical power systems important to safety – Separation*

IEC/IEEE 60780-323, *Nuclear facilities – Electrical equipment important safety – Qualification*

IEC 60964:2018, *Nuclear power plants – Control rooms – Design*

IEC/IEEE 60980-344, *Nuclear facilities – Equipment important to safety – Seismic qualification*

IEC 61225, *Nuclear power plants – Instrumentation, control and electrical power systems – Requirements for static uninterruptible DC and AC power supply systems*

IEC 61226:2020, *Nuclear power plants – Instrumentation, control and electrical power systems important to safety – Categorization of functions and classification of systems*

IEC 61513:2011, *Nuclear power plants – Instrumentation and control important to safety – General requirements for systems*

IEC 62671, *Nuclear power plants – Instrumentation and control important to safety – Selection and use of industrial digital devices of limited functionality*

IEC 62808, *Nuclear power plants – Instrumentation and control systems important to safety – Design and qualification of isolation devices*

IEC 62855:2016, *Nuclear power plants – Electrical power systems – Electrical power systems analysis*

IEC 62859, *Nuclear power plants – Instrumentation and control systems – Requirements for coordinating safety and cybersecurity*

IEC 63272, *Nuclear facilities – Electrical power systems – AC interruptible power supply systems*

ISO 9001:2015, *Quality management systems – Requirements*

IAEA Safety Guide GS-G-3.1:2006, *Application of the management System for facilities and activities*

IAEA GS-R, Part 2:2016, *Leadership and Management for Safety*

IAEA Safety Guide SSG-34:2016, *Design of electrical power systems in Nuclear Power Plants*

koniec náhľadu – text ďalej pokračuje v platenej verzii STN