

<b>STN</b>	<b>Systémy na komunikáciu po vysokonapäťových vedeniach pre aplikácie v energetike Časť 3: Terminály na digitálny prenos po vysokonapäťových vedeniach (DPLC) a hybridné terminály ADPLC</b>	<b>STN EN IEC 62488-3</b>  33 4691
------------	--	--

Power line communication systems for power utility applications - Part 3: Digital Power Line Carrier (DPLC) terminals and hybrid ADPLC terminals

Táto norma obsahuje anglickú verziu európskej normy.  
This standard includes the English version of the European Standard.

Táto norma bola oznámená vo Vestníku ÚNMS SR č. 08/21

Obsahuje: EN IEC 62488-3:2021, IEC 62488-3:2021

**133274**

EUROPEAN STANDARD

**EN IEC 62488-3**

NORME EUROPÉENNE

EUROPÄISCHE NORM

June 2021

ICS 33.200

English Version

**Power line communication systems for power utility applications  
- Part 3: Digital Power Line Carrier (DPLC) terminals and hybrid  
ADPLC terminals  
(IEC 62488-3:2021)**

Systèmes de communication sur lignes d'énergie pour les applications des compagnies d'électricité - Partie 3: Équipements terminaux à courants porteurs sur lignes d'énergie numériques ou DPLC et équipements terminaux hybrides ADPLC (IEC 62488-3:2021)

Systeme zur Kommunikation über Hochspannungsleitungen für Anwendungen der elektrischen Energieversorgung - Teil 3: Endgeräte für digitale Trägerfrequenzübertragung über Hochspannungsleitungen (DTFH) oder hybride ADTFH-Endgeräte (IEC 62488-3:2021)

This European Standard was approved by CENELEC on 2021-05-31. CENELEC members are bound to comply with the CEN/CENELEC Internal Regulations which stipulate the conditions for giving this European Standard the status of a national standard without any alteration.

Up-to-date lists and bibliographical references concerning such national standards may be obtained on application to the CEN-CENELEC Management Centre or to any CENELEC member.

This European Standard exists in three official versions (English, French, German). A version in any other language made by translation under the responsibility of a CENELEC member into its own language and notified to the CEN-CENELEC Management Centre has the same status as the official versions.

CENELEC members are the national electrotechnical committees of Austria, Belgium, Bulgaria, Croatia, Cyprus, the Czech Republic, Denmark, Estonia, Finland, France, Germany, Greece, Hungary, Iceland, Ireland, Italy, Latvia, Lithuania, Luxembourg, Malta, the Netherlands, Norway, Poland, Portugal, Republic of North Macedonia, Romania, Serbia, Slovakia, Slovenia, Spain, Sweden, Switzerland, Turkey and the United Kingdom.



European Committee for Electrotechnical Standardization  
Comité Européen de Normalisation Electrotechnique  
Europäisches Komitee für Elektrotechnische Normung

**CEN-CENELEC Management Centre: Rue de la Science 23, B-1040 Brussels**

**EN IEC 62488-3:2021 (E)****European foreword**

The text of document 57/2355/FDIS, future edition 1 of IEC 62488-3, prepared by IEC/TC 57 "Power systems management and associated information exchange" was submitted to the IEC-CENELEC parallel vote and approved by CENELEC as EN IEC 62488-3:2021.

The following dates are fixed:

- latest date by which the document has to be implemented at national level by publication of an identical national standard or by endorsement (dop) 2022-02-28
- latest date by which the national standards conflicting with the document have to be withdrawn (dow) 2024-05-31

Attention is drawn to the possibility that some of the elements of this document may be the subject of patent rights. CENELEC shall not be held responsible for identifying any or all such patent rights.

**Endorsement notice**

The text of the International Standard IEC 62488-3:2021 was approved by CENELEC as a European Standard without any modification.

In the official version, for Bibliography, the following note has to be added for the standard indicated:

IEC 60358    NOTE    Harmonized as HD 597 S1

## Annex ZA (normative)

### Normative references to international publications with their corresponding European publications

The following documents are referred to in the text in such a way that some or all of their content constitutes requirements of this document. For dated references, only the edition cited applies. For undated references, the latest edition of the referenced document (including any amendments) applies.

NOTE 1 Where an International Publication has been modified by common modifications, indicated by (mod), the relevant EN/HD applies.

NOTE 2 Up-to-date information on the latest versions of the European Standards listed in this annex is available here: [www.cenelec.eu](http://www.cenelec.eu).

<u>Publication</u>	<u>Year</u>	<u>Title</u>	<u>EN/HD</u>	<u>Year</u>
IEC 60038	-	IEC standard voltages	EN 60038	-
IEC 60050-151	2001	International Electrotechnical Vocabulary - - Part 151: Electrical and magnetic devices		-
IEC 60255-27	2013	Measuring relays and protection equipment - Part 27: Product safety requirements	EN 60255-27	2014
IEC 60529	1989	Degrees of protection provided by enclosures (IP Code)	EN 60529	1991
-	-		+ corrigendum May	1993
IEC 61000-4-2	-	Electromagnetic compatibility (EMC) - Part 4-2: Testing and measurement techniques - Electrostatic discharge immunity test	EN 61000-4-2	-
IEC 61000-4-3	-	Electromagnetic compatibility (EMC) - Part 4-3 : Testing and measurement techniques - Radiated, radio-frequency, electromagnetic field immunity test	EN IEC 61000-4-3	-
IEC 61000-4-4	-	Electromagnetic compatibility (EMC) - Part 4-4: Testing and measurement techniques - Electrical fast transient/burst immunity test	EN 61000-4-4	-
IEC 61000-4-5	-	Electromagnetic compatibility (EMC) - Part 4-5: Testing and measurement techniques - Surge immunity test	EN 61000-4-5	-
IEC 61000-6-2	-	Electromagnetic compatibility (EMC) - Part 6-2: Generic standards - Immunity standard for industrial environments	EN IEC 61000-6-2	-
IEC 60721-3-1	1997	Classification of environmental conditions - - - Part 3: Classification of groups of environmental parameters and their severities -- Section 1: Storage		-

**EN IEC 62488-3:2021 (E)**

<u>Publication</u>	<u>Year</u>	<u>Title</u>	<u>EN/HD</u>	<u>Year</u>
IEC 60721-3-3	2002	Classification of environmental conditions - Part 3-3: Classification of groups of environmental parameters and their severities - Stationary use at weatherprotected locations		-
IEC 60834-1	1999	Teleprotection equipment of power systems - Performance and testing - Part 1: Command systems	EN 60834-1	1999
IEC 61000-6-4	2018	Electromagnetic compatibility (EMC) - Part 6-4: Generic standards - Emission standard for industrial environments	EN IEC 61000-6-4	2019
IEC 61000-6-5	2015	Electromagnetic compatibility (EMC) - Part 6-5: Generic standards - Immunity for equipment used in power station and substation environment	EN 61000-6-5	2015
IEC 62488-1	2012	Power line communication systems for power utility applications - Part 1: Planning of analogue and digital power line carrier systems operating over EHV/HV/MV electricity grids	EN 62488-1	2013
IEC/TS 62351-1	2007	Power systems management and - associated information exchange - Data and communications security - Part 1: Communication network and system security - Introduction to security issues		-
IEC/TS 62351-8	2011	Power systems management and - associated information exchange - Data and communications security - Part 8: Role-based access control		-
IEC 62488-2	2017	Power line communication systems for power utility applications - Part 2: Analogue power line carrier terminals or APLC	EN 62488-2	2017
CISPR 32:2015/A1	2019	Electromagnetic compatibility of multimedia equipment - Emission requirements	EN 55032/A1	2020



IEC 62488-3

Edition 1.0 2021-04

# INTERNATIONAL STANDARD



---

**Power line communication systems for power utility applications –  
Part 3: Digital Power Line Carrier (DPLC) Terminals and hybrid  
ADPLC Terminals**





**THIS PUBLICATION IS COPYRIGHT PROTECTED**  
**Copyright © 2021 IEC, Geneva, Switzerland**

All rights reserved. Unless otherwise specified, no part of this publication may be reproduced or utilized in any form or by any means, electronic or mechanical, including photocopying and microfilm, without permission in writing from either IEC or IEC's member National Committee in the country of the requester. If you have any questions about IEC copyright or have an enquiry about obtaining additional rights to this publication, please contact the address below or your local IEC member National Committee for further information.

IEC Central Office  
3, rue de Varembe  
CH-1211 Geneva 20  
Switzerland

Tel.: +41 22 919 02 11  
[info@iec.ch](mailto:info@iec.ch)  
[www.iec.ch](http://www.iec.ch)

#### **About the IEC**

The International Electrotechnical Commission (IEC) is the leading global organization that prepares and publishes International Standards for all electrical, electronic and related technologies.

#### **About IEC publications**

The technical content of IEC publications is kept under constant review by the IEC. Please make sure that you have the latest edition, a corrigendum or an amendment might have been published.

#### **IEC publications search - [webstore.iec.ch/advsearchform](http://webstore.iec.ch/advsearchform)**

The advanced search enables to find IEC publications by a variety of criteria (reference number, text, technical committee, ...). It also gives information on projects, replaced and withdrawn publications.

#### **IEC Just Published - [webstore.iec.ch/justpublished](http://webstore.iec.ch/justpublished)**

Stay up to date on all new IEC publications. Just Published details all new publications released. Available online and once a month by email.

#### **IEC Customer Service Centre - [webstore.iec.ch/csc](http://webstore.iec.ch/csc)**

If you wish to give us your feedback on this publication or need further assistance, please contact the Customer Service Centre: [sales@iec.ch](mailto:sales@iec.ch).

#### **IEC online collection - [oc.iec.ch](http://oc.iec.ch)**

Discover our powerful search engine and read freely all the publications previews. With a subscription you will always have access to up to date content tailored to your needs.

#### **Electropedia - [www.electropedia.org](http://www.electropedia.org)**

The world's leading online dictionary on electrotechnology, containing more than 22 000 terminological entries in English and French, with equivalent terms in 18 additional languages. Also known as the International Electrotechnical Vocabulary (IEV) online.



IEC 62488-3

Edition 1.0 2021-04

# INTERNATIONAL STANDARD



---

**Power line communication systems for power utility applications –  
Part 3: Digital Power Line Carrier (DPLC) Terminals and hybrid  
ADPLC Terminals**

INTERNATIONAL  
ELECTROTECHNICAL  
COMMISSION

---

ICS 33.200

ISBN 978-2-8322-9698-1

**Warning! Make sure that you obtained this publication from an authorized distributor.**



## CONTENTS

FOREWORD.....	7
INTRODUCTION.....	9
1 Scope.....	10
2 Normative references .....	11
3 Terms, definitions and abbreviated terms .....	12
3.1 Terms and definitions.....	12
3.2 Abbreviated terms.....	13
4 Generic structure of DPLC and ADPLC terminals .....	14
5 Access side interfaces.....	17
5.1 General.....	17
5.2 Digital interfaces.....	17
5.2.1 Ethernet IEEE 802.3 interface.....	17
5.2.2 Serial interface .....	18
5.3 Analogue interfaces .....	18
5.4 Teleprotection system interface .....	19
5.4.1 Description .....	19
5.4.2 Integrated teleprotection.....	19
5.4.3 Teleprotection interface frequency band .....	19
5.4.4 Teleprotection interface impedance .....	19
5.4.5 Teleprotection interface reflection.....	19
5.4.6 Teleprotection interface signal levels.....	20
5.4.7 Teleprotection interface control circuits.....	20
6 HF line interface .....	20
6.1 DPLC high frequency band & channeling .....	20
6.2 Frequency accuracy.....	21
6.3 Signal levels .....	21
6.4 In-band emissions.....	21
6.5 Nominal impedance .....	21
6.6 Return loss .....	21
6.7 Degree of unbalance to earth.....	21
6.8 Tapping loss .....	21
6.9 Spurious emissions.....	22
6.10 Nominal output power in the high frequency band .....	23
7 Quality and performance.....	23
7.1 General.....	23
7.2 Dynamic range of the DPLC receiver .....	24
7.3 Bit rate.....	24
7.4 Start-up time .....	25
7.5 Recovery time after synchronization loss .....	25
7.6 Sensitivity .....	25
7.7 Selectivity .....	25
7.8 Adaptability to line conditions.....	25
7.9 Quality of voice channels .....	25
7.10 Telephone signalling transmission .....	26

7.11	Quality on the serial DATA channels .....	26
7.11.1	General .....	26
7.11.2	Bit rate .....	26
7.11.3	BER.....	26
7.11.4	Nominal transmission link delay.....	27
7.12	Quality of the frame transmission using Ethernet interfaces .....	27
7.12.1	General .....	27
7.12.2	LAN to LAN Speed .....	27
7.12.3	LAN to LAN latency .....	27
7.12.4	Packet loss on the LAN transfer.....	27
8	Testing .....	27
8.1	General.....	27
8.2	Test setup for DPLC link tests.....	28
8.3	Signal to noise ratio .....	28
8.4	Return loss .....	28
8.5	Degree of unbalance to earth.....	30
8.5.1	General .....	30
8.5.2	Longitudinal conversion loss.....	30
8.5.3	Output signal balance .....	31
8.6	Tapping loss .....	31
8.7	Spurious and in-band emissions .....	32
8.8	Selectivity .....	33
8.9	Bit error rate .....	35
8.10	Serial data transmission delay .....	37
8.11	Dynamic range of the DPLC receiver .....	38
8.12	LAN to LAN testing .....	38
8.12.1	General .....	38
8.12.2	Maximum LAN to LAN throughput.....	39
8.12.3	LAN to LAN latency .....	39
8.13	Start-up time .....	39
8.14	Recovery time after synchronization loss .....	39
9	Configuration and management .....	40
9.1	General.....	40
9.2	Configuration .....	40
9.3	Network management system .....	40
9.4	Local terminal alarms.....	40
9.5	Event logging.....	41
10	Cyber security .....	41
10.1	General.....	41
10.2	Transmitted payload .....	41
10.3	Management interface .....	41
10.3.1	General .....	41
10.3.2	Legacy-style management interfaces / Manufacturer-specific management interfaces .....	42
10.3.3	LAN/WAN connected management interfaces .....	42
10.3.4	Authentication and role-base model.....	42

10.4	Network management system interface .....	42
10.5	Security-related event logging.....	43
11	DPLC safety .....	43
11.1	General.....	43
11.2	Safety reference standard .....	43
11.3	Classification of DPLC terminals .....	43
11.4	Ingress protection .....	44
11.5	Type and routine tests .....	45
12	Storage and transportation, operating conditions, power supply.....	47
12.1	Storage and transportation.....	47
12.1.1	Climatic conditions .....	47
12.1.2	Mechanical .....	48
12.2	Operating conditions .....	50
12.2.1	Climatic conditions .....	50
12.2.2	Mechanical .....	51
12.2.3	Operating conditions set of tests.....	51
12.3	Power supply .....	52
12.3.1	AC supply .....	52
12.3.2	DC supply.....	52
13	EMC .....	53
13.1	Emission and immunity reference standards .....	53
13.2	Emission .....	53
13.2.1	Radiated and conducted emission .....	53
13.2.2	Low frequency disturbance emission .....	58
13.3	Immunity .....	58
13.3.1	EMC environment .....	58
13.3.2	Functional requirements .....	60
13.3.3	Immunity test list .....	60
Annex A (informative)	HF modulated power signal for ADPLC.....	63
A.1	General.....	63
A.2	Computation model of ADPLC.....	63
A.3	Distribution of E/U ratio of voice channels.....	65
A.4	Distribution of E/U ratio of sinusoidal waves.....	67
A.5	Example of E/U ratio of a digital signal.....	68
A.6	Composite distribution of E/U ratios .....	69
A.7	RMS power and load capacity of voice signals .....	71
A.8	Comprehensive load capacity for ADPLC .....	73
A.9	Simplified computation method for comprehensive load capacity .....	74
Bibliography	.....	75
Figure 1	– Schematic representation of the elements needed to implement a PLC system.....	11
Figure 2	– Generic architecture of a DPLC terminal .....	15
Figure 3	– Generic structure of an ADPLC terminal.....	16
Figure 4	– ETH IEEE 802.3 RJ45 type connector .....	17
Figure 5	– ETH IEEE 802.3 SC type connector .....	18

Figure 6 – Tapping loss limits for DPLC terminals .....	22
Figure 7 – Max level of spurious emissions outside the high frequency band .....	23
Figure 8 – Reference points for measuring DPLC parameters .....	24
Figure 9 – Block diagram of a serial data channel .....	26
Figure 10 – Test circuit for return loss measurement.....	29
Figure 11 – Test circuit for LCL measurement (transmission port).....	30
Figure 12 – Test circuit for OSB measurement (Rx port) .....	31
Figure 13 – Test circuit for tapping loss measurement .....	32
Figure 14 – Test circuit for spurious and in-band emissions measurement .....	33
Figure 15 – Test circuit for selectivity measurement.....	34
Figure 16 – Test circuit for bit error rate measurement.....	36
Figure 17 – Test circuit for serial data transmission delay measurement with a data tester .....	37
Figure 18 – Test circuit for serial data transmission delay measurement.....	37
Figure 19 – Test circuit for maximal throughput and latency measurement.....	38
Figure 20 – LF disturbances measurement setup .....	58
Figure A.1 – Calculation model of load capacity for ADPLC .....	64
Figure A.2 – Cumulative distributions of E/U ratio of voice channels for positive half .....	66
Figure A.3 – Probability density of combined sine waves .....	67
Figure A.4 – Constellation diagram of 64 QAM.....	68
Figure A.5 – Amplitude spectra of unmodulated OFDM sub-carriers.....	68
Figure A.6 – Probability of constellation point power in 64 QAM.....	69
Figure A.7 – Cumulative distribution of comprehensive E/U ratios.....	70
Figure A.8 – Cumulative distribution of equivalent volume for N system channel.....	72
Table 1 – Dependence of voice channel quality vs. DPLC capacity .....	26
Table 2 – Basic insulation (Table C.6 of IEC 60255-27:2013).....	43
Table 3 – Double or reinforced insulation (Table C.10 of IEC 60255-27:2013) .....	44
Table 4 – List of Type and Routine Tests (Table 12 of IEC 60255-27:2013) .....	46
Table 5 – Classification of climatic conditions (Table 1 of IEC 60721-3-1:1997) .....	47
Table 6 – Climatic tests for storage and transportation.....	48
Table 7 – Classification of mechanical conditions for transportation (Table 5 of IEC 60721-3-2:1997) .....	49
Table 8 – Classification of climatic conditions from Table 1 of IEC 60721-3-3:2002 .....	50
Table 9 – Classification of mechanical conditions from Table 6 of IEC 60721-3-3:2002.....	51
Table 10 – Climatic Tests .....	51
Table 11 – Sinusoidal vibration test .....	52
Table 12 – Non-repetitive shock test.....	52
Table 13 – Emission – Enclosure port (Table 1 of IEC 61000-6-4:2011).....	54
Table 14 – Emission – Low voltage AC and DC mains port (Table 2 of IEC 61000-6-4:2011).....	56
Table 15 – Emission – Telecommunications/network port (Table 3 of IEC 61000-6-4:2011).....	57
Table 16 – Characterization of the electromagnetic phenomena (Table 1 of IEC 61000-6-5:2015).....	59
Table 17 – Port classification .....	59

Table 18 – Performance criteria .....	60
Table 19 – Immunity test list .....	61
Table A.1 – Approximation formula for E/U cumulative distribution of speech.....	66
Table A.2 – PDF of constellation point power in 64 QAM constellation diagram .....	69
Table A.3 – Calculation of $P_{RMS}(1\%)$ and load capacity.....	73

## INTERNATIONAL ELECTROTECHNICAL COMMISSION

---

**POWER LINE COMMUNICATION SYSTEMS  
FOR POWER UTILITY APPLICATIONS –**
**Part 3: Digital Power Line Carrier (DPLC) Terminals  
and hybrid ADPLC Terminals**

## FOREWORD

- 1) The International Electrotechnical Commission (IEC) is a worldwide organization for standardization comprising all national electrotechnical committees (IEC National Committees). The object of IEC is to promote international co-operation on all questions concerning standardization in the electrical and electronic fields. To this end and in addition to other activities, IEC publishes International Standards, Technical Specifications, Technical Reports, Publicly Available Specifications (PAS) and Guides (hereafter referred to as "IEC Publication(s)"). Their preparation is entrusted to technical committees; any IEC National Committee interested in the subject dealt with may participate in this preparatory work. International, governmental and non-governmental organizations liaising with the IEC also participate in this preparation. IEC collaborates closely with the International Organization for Standardization (ISO) in accordance with conditions determined by agreement between the two organizations.
- 2) The formal decisions or agreements of IEC on technical matters express, as nearly as possible, an international consensus of opinion on the relevant subjects since each technical committee has representation from all interested IEC National Committees.
- 3) IEC Publications have the form of recommendations for international use and are accepted by IEC National Committees in that sense. While all reasonable efforts are made to ensure that the technical content of IEC Publications is accurate, IEC cannot be held responsible for the way in which they are used or for any misinterpretation by any end user.
- 4) In order to promote international uniformity, IEC National Committees undertake to apply IEC Publications transparently to the maximum extent possible in their national and regional publications. Any divergence between any IEC Publication and the corresponding national or regional publication shall be clearly indicated in the latter.
- 5) IEC itself does not provide any attestation of conformity. Independent certification bodies provide conformity assessment services and, in some areas, access to IEC marks of conformity. IEC is not responsible for any services carried out by independent certification bodies.
- 6) All users should ensure that they have the latest edition of this publication.
- 7) No liability shall attach to IEC or its directors, employees, servants or agents including individual experts and members of its technical committees and IEC National Committees for any personal injury, property damage or other damage of any nature whatsoever, whether direct or indirect, or for costs (including legal fees) and expenses arising out of the publication, use of, or reliance upon, this IEC Publication or any other IEC Publications.
- 8) Attention is drawn to the normative references cited in this publication. Use of the referenced publications is indispensable for the correct application of this publication.
- 9) Attention is drawn to the possibility that some of the elements of this IEC Publication may be the subject of patent rights. IEC shall not be held responsible for identifying any or all such patent rights.

This International Standard has been prepared by IEC technical committee 57: Power systems management and associated information exchange.

This first edition of IEC 62488-3 cancels and replaces the relevant parts of IEC TR 60663 and IEC 60495, which will be withdrawn at a later date.

The text of this standard is based on the following documents:

FDIS	Report on voting
57/2355/FDIS	57/2372/RVD

Full information on the voting for the approval of this standard can be found in the report on voting indicated in the above table.

This publication has been drafted in accordance with the ISO/IEC Directives, Part 2.

A list of all the parts in the IEC 62488 series, published under the general title *Power line communication systems for power utility applications* can be found on the IEC website

The committee has decided that the contents of this publication will remain unchanged until the stability date indicated on the IEC website under "<http://webstore.iec.ch>" in the data related to the specific document. At this date, the document will be

- reconfirmed,
- withdrawn,
- replaced by a revised edition, or
- amended.

**IMPORTANT – The 'colour inside' logo on the cover page of this publication indicates that it contains colours which are considered to be useful for the correct understanding of its contents. Users should therefore print this document using a colour printer.**

## INTRODUCTION

Since the first introduction of power line carrier communications in the power systems industry this form of communication has become widely spread throughout the world. This worldwide development will be covered by new standards reflecting the current state of the art in digital PLC communications.

The communication services offered by modern digital power line carrier links and networks enable a high efficiency of data transmission and therefore a low level of operational costs of automation equipment especially for long high-voltage power transmission lines.

Analogue and digital PLC terminals may co-exist using principles of frequency division multiplexing, allowing a successive digitalization of PLC based communications.

Digital PLC terminals may also be combined with traditional analogue PLC transmission paths as hybrid analog & digital PLC equipment, offering reliable and seamless communication for control and/or protection operating at extra high-, high- and medium-voltage levels of the electrical transmission networks and at high-voltage electrical distribution networks.

IEC 62488 consists of four parts dealing with all aspects of power line communication systems operating over electricity power lines.

IEC 62488 applies to power line carrier terminals and systems (PLC) used to transmit information over power networks including extra high, high and medium voltage (EHV/HV/MV) power lines.

Currently this standard series is organised as follows:

- IEC 62488-1, *Planning of analogue and digital power line carrier systems operating over EHV/HV/MV electricity grids*
- IEC 62488-2, *Analogue Power Line Carrier terminals or APLC*
- IEC 62488-3, *Digital Power Line Carrier terminals or DPLC and hybrid ADPLC Terminals*
- IEC 62488-4, *Broadband Power Line systems or BPL*

NOTE IEC 62488-4 has not yet been published.

This document is the third part of IEC 62488 and is composed of the following Clauses:

- Clause 1 – Scope of IEC 62488-3
- Clause 2 – Normative references
- Clause 3 – Terms, definitions and abbreviation contains newly introduce in this document additionally to IEC 62488-1 and IEC 62488-2
- Clause 4 – Introduces generic architectures of DPLC and hybrid ADPLC terminals.
- Clause 5 – Defines access side interfaces of DPLC and hybrid ADPLC terminals.
- Clause 6 – Describes transmission line side high frequency interface and defines related parameters
- Clause 7 – Gives several requirements concerning quality and performance of a single or a couple of interconnected DPLC terminals
- Clause 8 – Defines test setup and describes testing methodology
- Clause 9 – Describes configuration and management requirements for DPLC terminals
- Clause 10 – Describes general requirements regarding cyber security
- Clause 11 – Specifies safety requirements
- Clause 12 – Specifies requirements for storage and transportation, operating conditions, power supply
- Clause 13 – Specifies EMC requirements



## **POWER LINE COMMUNICATION SYSTEMS FOR POWER UTILITY APPLICATIONS –**

### **Part 3: Digital Power Line Carrier (DPLC) Terminals and hybrid ADPLC Terminals**

#### **1 Scope**

This part of IEC 62488 applies to power line carrier terminals and networks used to transmit information over power networks including extra high, high and medium voltage (EHV/HV/MV) power lines using both digital and optionally analogue modulation systems in a frequency range between 16 kHz and 1 MHz (see also IEC 62488-1).

In many countries, power line carrier (PLC) channels represent a significant part of the utility-owned telecommunication system. A circuit normally routed via a PLC channel can also be routed via a channel using a different transmission medium such as point to point radio, optical fibre or open wire circuit.

It is therefore important that the input and output interfaces that are used between terminals in the communication system are standardised.

The issues requiring consideration of DPLC and/or APLC devices as parts of a telecommunication network can be found in IEC 62488-1.

Figure 1 shows the correspondence between the elements needed to implement PLC systems and the related International Standards.

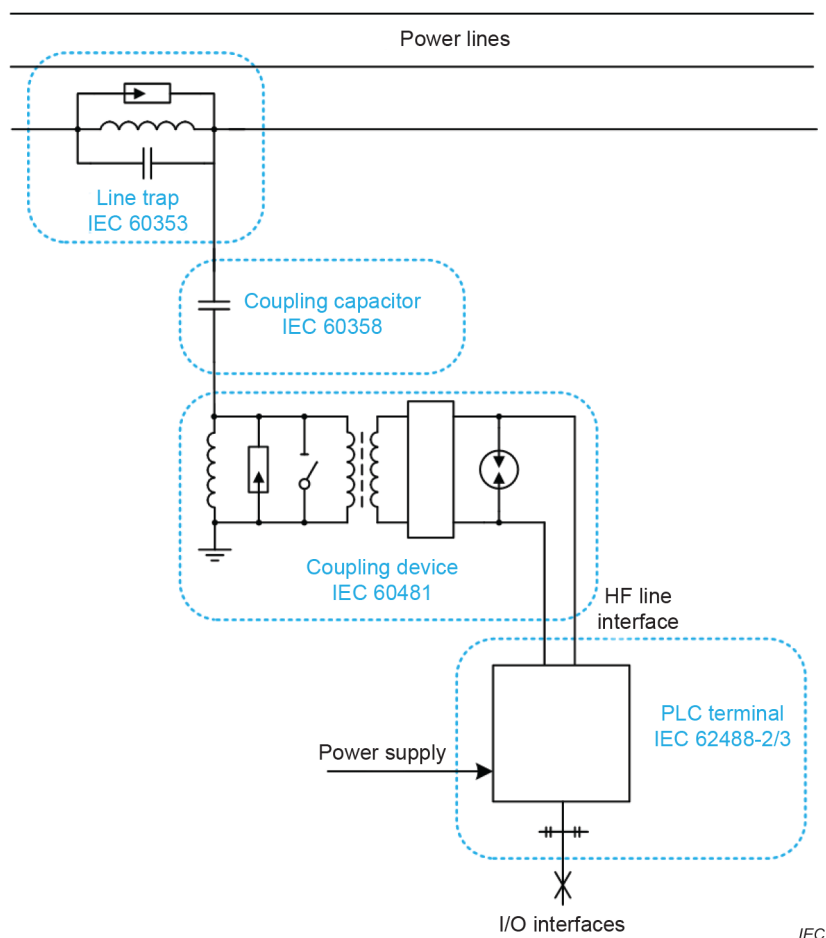

**Figure 1 – Schematic representation of the elements needed to implement a PLC system**

The scope of this document also includes the description of I/O interfaces and test set-ups that are necessary to qualify characteristics of DPLC or ADPLC terminal at link level.

## 2 Normative references

The following documents are referred to in the text in such a way that some or all of their content constitutes requirements of this document. For dated references, only the edition cited applies. For undated references, the latest edition of the referenced document (including any amendments) applies.

IEC 60038, *IEC standard voltages*

IEC 60050-151:2001, *International Electrotechnical Vocabulary (IEV) – Part 151: Electrical and magnetic devices*

IEC 60255-27:2013, *Measuring relays and protection equipment – Part 27: Product safety requirements*

IEC 60529:1989, *Degrees of protection provided by enclosures (IP Code)*

IEC 61000-4-2, *Electromagnetic compatibility (EMC) – Part 4-2: Testing and measurement techniques – Electrostatic discharge immunity test*

IEC 61000-4-3, *Electromagnetic compatibility (EMC) – Part 4-3: Testing and measurement techniques – Radiated, radio-frequency, electromagnetic field immunity test*

IEC 61000-4-4, *Electromagnetic compatibility (EMC) – Part 4-4: Testing and measurement techniques – Electrical fast transient/burst immunity test*

IEC 61000-4-5, *Electromagnetic compatibility (EMC) – Part 4-5: Testing and measurement techniques – Surge immunity test*

IEC 61000-6-2, *Electromagnetic compatibility (EMC) – Part 6-2: Generic standards – Immunity standard for industrial environments*

IEC 60721-3-1:1997, *Classification of environmental conditions – Part 3-1: Classification of groups of environmental parameters and their severities – Storage*

IEC 60721-3-3:2002, *Classification of environmental conditions – Part 3: Classification of groups of environmental parameters and their severities – Stationary use at weather protected locations*

IEC 60834-1:1999, *Teleprotection equipment of power systems – Performance and testing – Part 1: Command systems*

IEC 61000-6-4:2018, *Electromagnetic compatibility (EMC) – Part 6-4: Generic standards – Emission standard for industrial environments*

IEC 61000-6-5:2015, *Electromagnetic compatibility (EMC) – Part 6-5: Generic standards – Immunity for equipment used in power station and substation environment*

IEC TS 62351-1:2007, *Power systems management and associated information exchange – Data and communications security – Part 1: Communication network and system security – Introduction to security issues*

IEC TS 62351-8:2011, *Power systems management and associated information exchange – Data and communications security – Part 8: Role-based access control*

IEC 62488-1:2012, *Power line communication systems for power utility applications – Part 1: Planning of analogue and digital power line carrier systems operating over EHV/HV/MV electricity grids*

IEC 62488-2:2017, *Power line communication systems for power utility applications – Part 2: Analogue power line carrier terminals or APLC*

CISPR 32:2015/AMD1:2019, *Electromagnetic compatibility of multimedia equipment – Emission requirements*

**koniec náhľadu – text ďalej pokračuje v platenej verzii STN**