

STN	Integrácia podnikových riadiacich systémov Časť 6: Model služby zasielania správ	STN EN IEC 62264-6 18 4411
------------	---	--

Enterprise-control system integration - Part 6: Messaging service model

Táto norma obsahuje anglickú verziu európskej normy.
This standard includes the English version of the European Standard.

Táto norma bola oznámená vo Vestníku ÚNMS SR č. 06/22

Obsahuje: EN IEC 62264-6:2022, IEC 62264-6:2020

135098



EUROPEAN STANDARD
NORME EUROPÉENNE
EUROPÄISCHE NORM

EN IEC 62264-6

March 2022

ICS 25.040.40; 35.100.70

English Version

**Enterprise-control system integration - Part 6: Messaging service
model
(IEC 62264-6:2020)**

Intégration des systèmes entreprise-contrôle – Partie 6:
Modèle de service de messagerie
(IEC 62264-6:2020)

Integration von Unternehmensführungs- und Leitsystemen -
Teil 6: Dienstmodell zur Nachrichtenübermittlung
(IEC 62264-6:2020)

This European Standard was approved by CENELEC on 2021-12-29. CENELEC members are bound to comply with the CEN/CENELEC Internal Regulations which stipulate the conditions for giving this European Standard the status of a national standard without any alteration.

Up-to-date lists and bibliographical references concerning such national standards may be obtained on application to the CEN-CENELEC Management Centre or to any CENELEC member.

This European Standard exists in three official versions (English, French, German). A version in any other language made by translation under the responsibility of a CENELEC member into its own language and notified to the CEN-CENELEC Management Centre has the same status as the official versions.

CENELEC members are the national electrotechnical committees of Austria, Belgium, Bulgaria, Croatia, Cyprus, the Czech Republic, Denmark, Estonia, Finland, France, Germany, Greece, Hungary, Iceland, Ireland, Italy, Latvia, Lithuania, Luxembourg, Malta, the Netherlands, Norway, Poland, Portugal, Republic of North Macedonia, Romania, Serbia, Slovakia, Slovenia, Spain, Sweden, Switzerland, Turkey and the United Kingdom.



European Committee for Electrotechnical Standardization
Comité Européen de Normalisation Electrotechnique
Europäisches Komitee für Elektrotechnische Normung

CEN-CENELEC Management Centre: Rue de la Science 23, B-1040 Brussels

EN IEC 62264-6:2022 (E)**European foreword**

This document EN IEC 62264-6:2022 consists of the text of IEC 62264-6:2020 prepared by IEC/TC 65 "Devices and integration in enterprise systems".

The following dates are fixed:

- latest date by which the document has to be implemented at national level by publication of an identical national standard or by endorsement (dop) 2022-09-11
- latest date by which the national standards conflicting with the document have to be withdrawn (dow) 2025-03-11

Attention is drawn to the possibility that some of the elements of this document may be the subject of patent rights. CENELEC shall not be held responsible for identifying any or all such patent rights.

Any feedback and questions on this document should be directed to the users' national committee. A complete listing of these bodies can be found on the CENELEC website.

Endorsement notice

The text of the International Standard IEC 62264-6:2020 was approved by CENELEC as a European Standard without any modifications.

In the official version, for Bibliography, the following notes have to be added for the standards indicated:

IEC 62541-3:2015	NOTE	Harmonized as EN 62541-3:2015 (not modified)
IEC 62541-4:2015	NOTE	Harmonized as EN 62541-4:2015 (not modified)
IEC 62541-5:2015	NOTE	Harmonized as EN 62541-5:2015 (not modified)
IEC 62541-6:2015	NOTE	Harmonized as EN 62541-6:2015 (not modified)
IEC 62541-7:2015	NOTE	Harmonized as EN 62541-7:2015 (not modified)
IEC 62541-8:2015	NOTE	Harmonized as EN 62541-8:2015 (not modified)
IEC 62541-9:2015	NOTE	Harmonized as EN 62541-9:2015 (not modified)
IEC 62541-10:2015	NOTE	Harmonized as EN 62541-10:2015 (not modified)
IEC 62541-11:2015	NOTE	Harmonized as EN 62541-11:2015 (not modified)

Annex ZA
(normative)

**Normative references to international publications
with their corresponding European publications**

The following documents are referred to in the text in such a way that some or all of their content constitutes requirements of this document. For dated references, only the edition cited applies. For undated references, the latest edition of the referenced document (including any amendments) applies.

NOTE 1 When an International Publication has been modified by common modifications, indicated by (mod), the relevant EN/HD applies.

NOTE 2 Up-to-date information on the latest versions of the European Standards listed in this annex is available here: www.cenelec.eu.

<u>Publication</u>	<u>Year</u>	<u>Title</u>	<u>EN/HD</u>	<u>Year</u>
IEC 62264-1	-	Enterprise-control system integration - Part 1: Models and terminology	EN 62264-1	-
IEC 62264-2	-	Enterprise-control system integration - Part 2: Object and attributes for enterprise-control system integration	EN 62264-2	-
IEC 62264-4	-	Enterprise-control system integration - Part 4: Objects models attributes for manufacturing operations management integration	EN 62264-4	-
IEC 62264-5	-	Enterprise-control system integration - Part 5: Business to manufacturing transactions	EN 62264-5	-



IEC 62264-6

Edition 1.0 2020-06

INTERNATIONAL STANDARD



Enterprise-control system integration – Part 6: Messaging service model



**THIS PUBLICATION IS COPYRIGHT PROTECTED****Copyright © 2020 IEC, Geneva, Switzerland**

All rights reserved. Unless otherwise specified, no part of this publication may be reproduced or utilized in any form or by any means, electronic or mechanical, including photocopying and microfilm, without permission in writing from either IEC or IEC's member National Committee in the country of the requester. If you have any questions about IEC copyright or have an enquiry about obtaining additional rights to this publication, please contact the address below or your local IEC member National Committee for further information.

IEC Central Office
3, rue de Varembe
CH-1211 Geneva 20
Switzerland

Tel.: +41 22 919 02 11
info@iec.ch
www.iec.ch

About the IEC

The International Electrotechnical Commission (IEC) is the leading global organization that prepares and publishes International Standards for all electrical, electronic and related technologies.

About IEC publications

The technical content of IEC publications is kept under constant review by the IEC. Please make sure that you have the latest edition, a corrigendum or an amendment might have been published.

IEC publications search - webstore.iec.ch/advsearchform

The advanced search enables to find IEC publications by a variety of criteria (reference number, text, technical committee,...). It also gives information on projects, replaced and withdrawn publications.

IEC Just Published - webstore.iec.ch/justpublished

Stay up to date on all new IEC publications. Just Published details all new publications released. Available online and once a month by email.

IEC Customer Service Centre - webstore.iec.ch/csc

If you wish to give us your feedback on this publication or need further assistance, please contact the Customer Service Centre: sales@iec.ch.

Electropedia - www.electropedia.org

The world's leading online dictionary on electrotechnology, containing more than 22 000 terminological entries in English and French, with equivalent terms in 16 additional languages. Also known as the International Electrotechnical Vocabulary (IEV) online.

IEC Glossary - std.iec.ch/glossary

67 000 electrotechnical terminology entries in English and French extracted from the Terms and Definitions clause of IEC publications issued since 2002. Some entries have been collected from earlier publications of IEC TC 37, 77, 86 and CISPR.



IEC 62264-6

Edition 1.0 2020-06

INTERNATIONAL STANDARD



Enterprise-control system integration – Part 6: Messaging service model

INTERNATIONAL
ELECTROTECHNICAL
COMMISSION

ICS 25.040.40; 35.100.70

ISBN 978-2-8322-8453-7

Warning! Make sure that you obtained this publication from an authorized distributor.

CONTENTS

FOREWORD.....	6
INTRODUCTION.....	8
1 Scope.....	11
2 Normative references	11
3 Terms, definitions, abbreviation, and conventions.....	11
3.1 Terms and definitions.....	11
3.2 Abbreviations.....	12
3.3 Conventions.....	13
4 Overview of the MSM	13
4.1 Positioning of the MSM	13
4.2 Abstract service model.....	14
4.3 Transaction models supported	14
4.4 Application roles	15
4.5 MSM channels	15
4.6 MSM channel services	16
4.6.1 Types of channel services	16
4.6.2 Channel management services	16
4.6.3 Publication channel services.....	16
4.6.4 Request channel services.....	17
4.7 Notify listener service	17
5 Methods of operation of channels	18
5.1 Channel and topic identification	18
5.2 Channel names and hierarchy.....	18
5.2.1 Channel names.....	18
5.2.2 Channel name hierarchy.....	18
5.2.3 MSM root.....	18
5.2.4 Channel scope.....	19
5.2.5 Information scope	19
5.2.6 Channel use	19
5.3 Publication expiration.....	20
5.4 Topics.....	21
5.4.1 Topic definition	21
5.4.2 Topic names	21
5.5 Sessions.....	22
5.6 Security	22
5.6.1 Secure message exchanges	22
5.6.2 Security tokens on channels	22
5.6.3 Security token format.....	23
5.6.4 MSM service provider implementations.....	23
6 Service definitions	23
6.1 Type definitions	23
6.2 Defined return value of services.....	24
6.3 Channel management services	25
6.3.1 Create channel	25
6.3.2 Add security tokens	25
6.3.3 Remove security tokens.....	26

6.3.4	Delete channel	26
6.3.5	Get channel	26
6.3.6	Get channels	27
6.4	Notify listener service	27
6.5	Provider publication services	28
6.5.1	Open publication session	28
6.5.2	Post publication	28
6.5.3	Expire publication	28
6.5.4	Close publication session	29
6.6	Consumer publication services	29
6.6.1	Open subscription session	29
6.6.2	Read publication	30
6.6.3	Remove publication	30
6.6.4	Close subscription session	31
6.7	Provider request services	31
6.7.1	Open provider request session	31
6.7.2	Read request	32
6.7.3	Remove request	32
6.7.4	Post response	33
6.7.5	Close provider request session	33
6.8	Consumer request services	33
6.8.1	Open consumer request session	33
6.8.2	Post request	34
6.8.3	Read response	34
6.8.4	Remove response	35
6.8.5	Close consumer request session	35
7	Scenarios	36
7.1	Publish-subscribe scenarios	36
7.1.1	Simple publish-subscribe scenario	36
7.1.2	Publish-subscribe scenario with multiple messages	36
7.1.3	Publish-subscribe scenario without notification	37
7.1.4	Multiple publisher scenario	38
7.1.5	Publish-subscribe scenario with publication expiration	39
7.2	Request channel scenarios	40
7.2.1	Request-response scenario with notification	40
7.2.2	Request-response scenario without notification	41
7.2.3	Multiple providers	42
8	Conformance	43
Annex A (informative) MSM service provider considerations		44
A.1	Service provider considerations	44
A.2	Notification	44
A.3	Security considerations	44
A.4	MSM application implementation considerations	44
A.5	MSM channel security considerations	45
A.6	MSM session ID considerations	45
A.7	Data format validation	45
A.8	Allowed application checking	45
A.9	Data exchange logging	45
A.10	Common error handling	45

A.11	Data transformation services.....	46
A.12	Cross company bridges.....	46
A.13	Message maintenance	47
Annex B (informative)	Enterprise Service Buses	48
Bibliography	50
Figure 1	– Steps in application-to-application communication	9
Figure 2	– Defined standards at each level	9
Figure 3	– Positioning and role of MSM.....	14
Figure 4	– Messaging service model terminology	15
Figure 5	– Channel management services	16
Figure 6	– Publication channel services	17
Figure 7	– Services for request.....	17
Figure 8	– Notify listener service.....	18
Figure 9	– Changes and checkpoint channel example	20
Figure 10	– Security of channels.....	23
Figure 11	– Publication scenario with notification.....	36
Figure 12	– Publication scenario with multiple messages	37
Figure 13	– Publication without notification	38
Figure 14	– Publication with multiple provider applications.....	39
Figure 15	– Publication with expired publications	40
Figure 16	– GET/SHOW request service scenario.....	41
Figure 17	– CHANGE / RESPONSE request service scenario	42
Figure 18	– Multiple providers CHANGE/RESPONSE scenario	43
Figure A.1	– Transformation services with the MSM service provider.....	46
Figure A.2	– Cross company bridge between multiple MSMs	47
Figure B.1	– Standard interface to ESBs and other message exchange systems.....	49
Table 1	– Application roles, channels, and services	16
Table 2	– Channel use for transaction verbs	19
Table 3	– Type definitions.....	24
Table 4	– Service fault definitions	24
Table 5	– Service parameter definitions	25
Table 6	– Create channel.....	25
Table 7	– Add security tokens.....	25
Table 8	– Remove security tokens	26
Table 9	– Delete channel	26
Table 10	– Get channel.....	27
Table 11	– Get channels	27
Table 12	– Notify listener	27
Table 13	– Open publication session	28
Table 14	– Post publication.....	28
Table 15	– Expire publication.....	29

Table 16 – Close publication session	29
Table 17 – Open subscription session.....	30
Table 18 – Read publication	30
Table 19 – Remove publication	31
Table 20 – Close subscription session	31
Table 21 – Open provider request session	32
Table 22 – Read request.....	32
Table 23 – Remove request	33
Table 24 – Post response	33
Table 25 – Close provider request session.....	33
Table 26 – Open consumer request session.....	34
Table 27 – Post request	34
Table 28 – Read response	35
Table 29 – Remove response	35
Table 30 – Close consumer request session	35

INTERNATIONAL ELECTROTECHNICAL COMMISSION

ENTERPRISE-CONTROL SYSTEM INTEGRATION –**Part 6: Messaging service model**

FOREWORD

- 1) The International Electrotechnical Commission (IEC) is a worldwide organization for standardization comprising all national electrotechnical committees (IEC National Committees). The object of IEC is to promote international co-operation on all questions concerning standardization in the electrical and electronic fields. To this end and in addition to other activities, IEC publishes International Standards, Technical Specifications, Technical Reports, Publicly Available Specifications (PAS) and Guides (hereafter referred to as "IEC Publication(s)"). Their preparation is entrusted to technical committees; any IEC National Committee interested in the subject dealt with may participate in this preparatory work. International, governmental and non-governmental organizations liaising with the IEC also participate in this preparation. IEC collaborates closely with the International Organization for Standardization (ISO) in accordance with conditions determined by agreement between the two organizations.
- 2) The formal decisions or agreements of IEC on technical matters express, as nearly as possible, an international consensus of opinion on the relevant subjects since each technical committee has representation from all interested IEC National Committees.
- 3) IEC Publications have the form of recommendations for international use and are accepted by IEC National Committees in that sense. While all reasonable efforts are made to ensure that the technical content of IEC Publications is accurate, IEC cannot be held responsible for the way in which they are used or for any misinterpretation by any end user.
- 4) In order to promote international uniformity, IEC National Committees undertake to apply IEC Publications transparently to the maximum extent possible in their national and regional publications. Any divergence between any IEC Publication and the corresponding national or regional publication shall be clearly indicated in the latter.
- 5) IEC itself does not provide any attestation of conformity. Independent certification bodies provide conformity assessment services and, in some areas, access to IEC marks of conformity. IEC is not responsible for any services carried out by independent certification bodies.
- 6) All users should ensure that they have the latest edition of this publication.
- 7) No liability shall attach to IEC or its directors, employees, servants or agents including individual experts and members of its technical committees and IEC National Committees for any personal injury, property damage or other damage of any nature whatsoever, whether direct or indirect, or for costs (including legal fees) and expenses arising out of the publication, use of, or reliance upon, this IEC Publication or any other IEC Publications.
- 8) Attention is drawn to the Normative references cited in this publication. Use of the referenced publications is indispensable for the correct application of this publication.
- 9) Attention is drawn to the possibility that some of the elements of this IEC Publication may be the subject of patent rights. IEC shall not be held responsible for identifying any or all such patent rights.

International Standard IEC 62264-6 has been prepared by subcommittee 65E: Devices and integration in enterprise systems, of IEC technical committee TC65: Industrial-process measurement, control and automation.

The text of this International Standard is based on the following documents:

FDIS	Report on voting
65E/706/FDIS	65E/724/RVD

Full information on the voting for the approval of this International Standard can be found in the report on voting indicated in the above table.

This document has been drafted in accordance with the ISO/IEC Directives, Part 2.

A list of all parts in the IEC 62264, published under the general title *Enterprise-control system integration*, can be found on the IEC website.

The committee has decided that the contents of this document will remain unchanged until the stability date indicated on the IEC website under "<http://webstore.iec.ch>" in the data related to the specific document. At this date, the document will be

- reconfirmed,
- withdrawn,
- replaced by a revised edition, or
- amended.

IMPORTANT – The 'colour inside' logo on the cover page of this publication indicates that it contains colours which are considered to be useful for the correct understanding of its contents. Users should therefore print this document using a colour printer.

INTRODUCTION

This document is based on the use of IEC 62264 object models defined in IEC 62264-2, IEC 62264-4 and IEC 62264-5 to define a set of services that may be used to exchange messages. This document defines a messaging service model (MSM) for exchanging messages in a publish-subscribe mode and a request-response mode.

The Messaging Service Model provides a method for applications to send and receive messages from MSM service providers without regard to the underlying communication mechanism, as part of a complete application-to-application data exchange.

This document defines a model for message exchange services (Messaging Service Model) that are designed to provide a technology independent method for sending and receiving transaction messages to or from underlying exchange services.

The knowledge requirements to interface to just one message exchange system can be immense and are usually not transferable to a different system. MSM defines a single interface, independent of the underlying exchange services, for exchanging data objects defined by IEC 62264-2 and by IEC 62264-4. This removes the need for vendors to build custom interface after custom interface, and for end users to get locked into a single vendor because their investment prevents them from reusing any of the integration efforts.

Exchanging the data objects between different computer system applications involves multiple different steps, as shown in Figure 1.

- a) The applications usually have different internal representations of exchanged objects in their own local data stores. This representation is usually converted from the local format to a commonly accepted global format. IEC 62264-2 defines models of a global format for Level 4-3 data exchanges. IEC 62264-4 defines models of a global format for Level 3-3 data exchanges. This conversion, from local to global and global to local, is usually performed twice for any two-way communications.

EXAMPLE 1 Assume two applications, ALPHA and BETA: the ALPHA application initiates a data exchange with the BETA application, and BETA responds back to ALPHA. The format conversions are: ALPHA's local format to global format for the request data, global format to BETA's local format for the request data, BETA's local format to global format for the response data, and global format to ALPHA's format for the response data.

- b) Conversion is performed to align the namespaces among the exchanging applications and is usually performed four times for any two-way communications.

EXAMPLE 2 Names for elements of data can be codes, tag names, or equipment identifiers.

EXAMPLE 3 Data which are represented in one element namespace, such as codes 1,2,3,4, can have a different namespace in another application, such as codes Ok, Done, Error, Delay.

- c) Once information is in the global format with global names, the exchanged information is sent from one application to another application.
- d) Messages are transported from one application to another, either within the same computer environment or across computers. Transport mechanisms are defined in other standards, such as TCP/IP and Ethernet standards.
- e) When data exchange information is received, there are specific rules that define what resultant data are to be returned. The transaction rules are defined in IEC 62264-5.

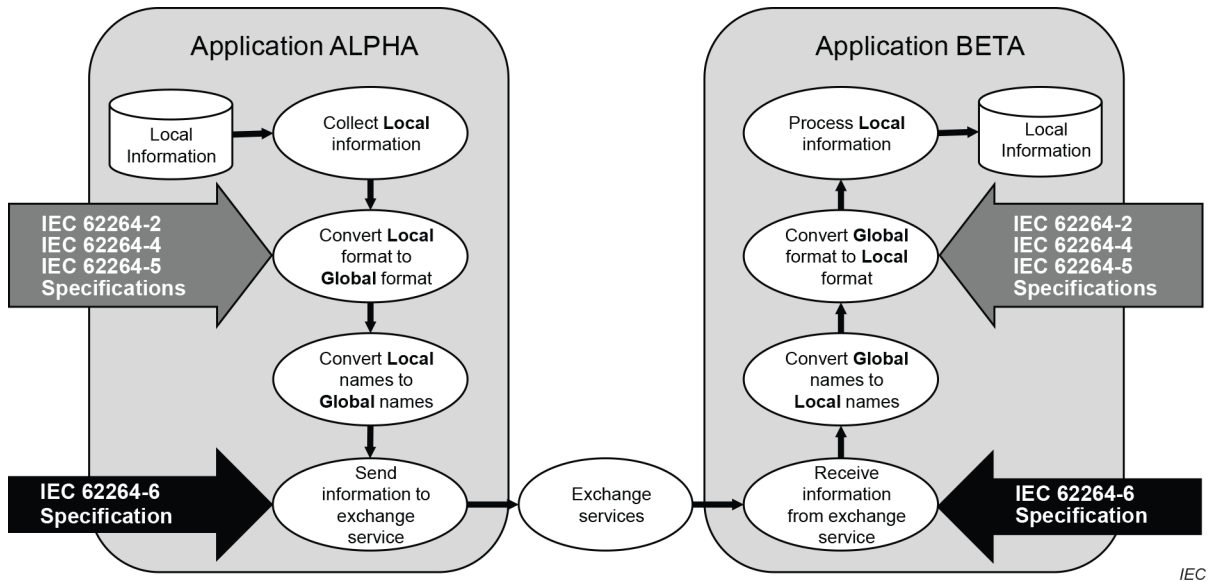

Figure 1 – Steps in application-to-application communication

MSM is a minimal interface subset that can reside on most exchange services and is based on well-defined and structured data objects and transaction messages.

Each layer shown in Figure 2 addresses a specific element of application data exchange.

- 1) A Data Object layer defines the meaning, format, and structure of the basic elements of exchanged information.

NOTE 1 This layer uses application space specific definitions, such as the IEC 62264-2 and IEC 62264-4 object definitions, MESA B2MML, MIMOSA CCOM objects, and "Nouns" defined in OAGIS.

- 2) A Transaction layer defines the meaning, format, and structure of actions to be taken on the data objects.

NOTE 2 This layer can use IEC 62264-5 transaction style specific definitions. Another transaction layer definition could be the OAGIS "Verb" definitions.

- 3) The MSM defines an interface to the OSI Application layer's services.
- 4) The application, presentation, session and lower level layers define the meaning, format, and structure for coordination, buffering, and exchange of messages or files. These layers contain transfer or exchange style specific definitions, such as Enterprise Service Buses, Enterprise Message Delivery Systems, the OPC UA specification (IEC 62541 standard), RSS, FTP, Named Pipes, Ethernet, TCP/IP, HTTP, and others.

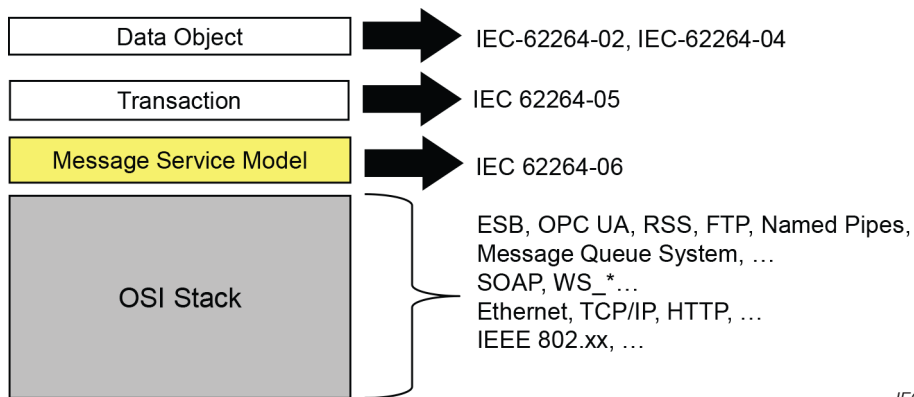

Figure 2 – Defined standards at each level

The IEC 62264-5 standard defines transactions on the information. The Messaging Service Model (MSM) defines an interface to methods for exchange. In a sense, MSM defines the standard "on-ramp" and "off-ramp" to the application layer services. It defines how data is placed into exchange methods and how it is retrieved from the exchange methods.

NOTE 1 Message synchronization using the MSM service is distinct from the message synchronization provided by the 62264-5 transaction models as well as distinct from the synchronization mechanisms provided at lower levels of the communications stack.

NOTE 2 In this document, asynchronous message exchanges between consumers and producers can be considered to be pairs of distinct, unidirectional messages.

This document includes two informative annexes. Annex A is informative. It provides considerations for (MSM) service providers. Annex B is informative. It provides a brief description of Enterprise Service Buses as a message exchange mechanism.

ENTERPRISE-CONTROL SYSTEM INTEGRATION –

Part 6: Messaging service model

1 Scope

This document defines a technology independent model for a set of abstract services that is located above the application layer of the OSI model, and that is used for exchanging transaction messages based on the transaction models defined in IEC 62264-5. The model, which is called the Messaging Service Model (MSM), is intended for interoperability between manufacturing operations domain applications and applications in other domains.

NOTE It is recognized that other sets of services not defined in accordance with this document are possible for the exchange of MOM information and are not deemed invalid as a result of this document.

2 Normative references

The following documents are referred to in the text in such a way that some or all of their content constitutes requirements of this document. For dated references, only the edition cited applies. For undated references, the latest edition of the referenced document (including any amendments) applies.

IEC 62264-1, *Enterprise-control system integration – Part 1: Models and terminology*

IEC 62264-2, *Enterprise-control system integration – Part 2: Object and attributes for enterprise-control system integration*

IEC 62264-4, *Enterprise-control system integration – Part 4: Objects models attributes for manufacturing operations management integration*

IEC 62264-5, *Enterprise-control system integration – Part 5: Business to manufacturing transactions*

koniec náhľadu – text ďalej pokračuje v platenej verzii STN