

STN	Priemyselné siete Jednosmerné digitálne komunikačné rozhranie Časť 2: Rozšírenie funkčnej bezpečnosti	STN EN IEC 61139-2 18 4020
------------	--	--

Industrial networks - Single-drop digital communication interface - Part 2: Functional safety extensions

Táto norma obsahuje anglickú verziu európskej normy.
This standard includes the English version of the European Standard.

Táto norma bola oznámená vo Vestníku ÚNMS SR č. 12/22

Obsahuje: EN IEC 61139-2:2022, IEC 61139-2:2022

EUROPEAN STANDARD
NORME EUROPÉENNE
EUROPÄISCHE NORM

EN IEC 61139-2

September 2022

ICS 25.040

English Version

**Industrial networks - Single-drop digital communication interface
- Part 2: Functional safety extensions
(IEC 61139-2:2022)**

Réseaux industriels - Interface de communication
numérique point à point - Partie 2: Extensions de sécurité
fonctionnelle
(IEC 61139-2:2022)

Industrielle Netzwerke - Digitale Single-Drop-
Kommunikationsschnittstelle - Teil 2: Erweiterungen für die
funktionale Sicherheit
(IEC 61139-2:2022)

This European Standard was approved by CENELEC on 2022-09-23. CENELEC members are bound to comply with the CEN/CENELEC Internal Regulations which stipulate the conditions for giving this European Standard the status of a national standard without any alteration.

Up-to-date lists and bibliographical references concerning such national standards may be obtained on application to the CEN-CENELEC Management Centre or to any CENELEC member.

This European Standard exists in three official versions (English, French, German). A version in any other language made by translation under the responsibility of a CENELEC member into its own language and notified to the CEN-CENELEC Management Centre has the same status as the official versions.

CENELEC members are the national electrotechnical committees of Austria, Belgium, Bulgaria, Croatia, Cyprus, the Czech Republic, Denmark, Estonia, Finland, France, Germany, Greece, Hungary, Iceland, Ireland, Italy, Latvia, Lithuania, Luxembourg, Malta, the Netherlands, Norway, Poland, Portugal, Republic of North Macedonia, Romania, Serbia, Slovakia, Slovenia, Spain, Sweden, Switzerland, Türkiye and the United Kingdom.



European Committee for Electrotechnical Standardization
Comité Européen de Normalisation Electrotechnique
Europäisches Komitee für Elektrotechnische Normung

CEN-CENELEC Management Centre: Rue de la Science 23, B-1040 Brussels

EN IEC 61139-2:2022 (E)**European foreword**

The text of document 65C/1168/FDIS, future edition 1 of IEC 61139-2, prepared by SC 65C "Industrial networks" of IEC/TC 65 "Industrial-process measurement, control and automation" was submitted to the IEC-CENELEC parallel vote and approved by CENELEC as EN IEC 61139-2:2022.

The following dates are fixed:

- latest date by which the document has to be implemented at national level by publication of an identical national standard or by endorsement (dop) 2023-06-23
- latest date by which the national standards conflicting with the document have to be withdrawn (dow) 2025-09-23

Attention is drawn to the possibility that some of the elements of this document may be the subject of patent rights. CENELEC shall not be held responsible for identifying any or all such patent rights.

Any feedback and questions on this document should be directed to the users' national committee. A complete listing of these bodies can be found on the CENELEC website.

Endorsement notice

The text of the International Standard IEC 61139-2:2022 was approved by CENELEC as a European Standard without any modification.

In the official version, for Bibliography, the following notes have to be added for the standards indicated:

IEC 61784-3 (series) NOTE Harmonized as EN IEC 61784-3 (series)

IEC 60947-5-2 NOTE Harmonized as EN IEC 60947-5-2

IEC 62769 (series) NOTE Harmonized as EN IEC 62769 (series)

IEC 60947-5-6 NOTE Harmonized as EN 60947-5-6

IEC 62453 (series) NOTE Harmonized as EN 62453 (series)

IEC 60947-5-3 NOTE Harmonized as EN 60947-5-3

IEC 61076-2-113 NOTE Harmonized as EN 61076-2-113

IEC 61508-4:2010 NOTE Harmonized as EN 61508-4:2010 (not modified)

Annex ZA (normative)

Normative references to international publications with their corresponding European publications

The following documents are referred to in the text in such a way that some or all of their content constitutes requirements of this document. For dated references, only the edition cited applies. For undated references, the latest edition of the referenced document (including any amendments) applies.

NOTE 1 Where an International Publication has been modified by common modifications, indicated by (mod), the relevant EN/HD applies.

NOTE 2 Up-to-date information on the latest versions of the European Standards listed in this annex is available here: www.cenelec.eu.

<u>Publication</u>	<u>Year</u>	<u>Title</u>	<u>EN/HD</u>	<u>Year</u>
IEC 60204-1	-	Safety of machinery - Electrical equipment of machines - Part 1: General requirements	EN 60204-1	-
IEC 61010-2-201	-	Safety requirements for electrical equipment for measurement, control, and laboratory use - Part 2-201: Particular requirements for control equipment	EN IEC 61010-2-201	-
IEC 61131-2	-	Industrial-process measurement and control - Programmable controllers - Part 2: Equipment requirements and tests	-	-
IEC 61131-9	2022	Programmable controllers - Part 9: Single-drop digital communication interface for small sensors and actuators (SDCI)	EN IEC 61131-9	2022
IEC 61496-1	-	Safety of machinery - Electro-sensitive protective equipment - Part 1: General requirements and tests	EN IEC 61496-1	-
IEC 61508-3	-	Functional safety of electrical/electronic/programmable electronic safety-related systems - Part 3: Software requirements	EN 61508-3	-
IEC 61784-3	2021	Industrial communication networks - Profiles - Part 3: Functional safety fieldbuses - General rules and profile definitions	EN IEC 61784-3	2021
IEC 62061	-	Safety of machinery - Functional safety of safety-related control systems	EN IEC 62061	-
IEC 62443	series	Security for industrial automation and control systems	EN IEC 62443	series
ISO 639-2	-	Codes for the representation of names of languages - Part-2: Alpha-3 code	-	-
ISO 639-3	-	Codes for the representation of names of languages - Part 3: Alpha-3 code for comprehensive coverage of languages	-	-

EN IEC 61139-2:2022 (E)

ISO 13849-1 - Safety of machinery - Safety-related parts of control systems - Part 1: General principles for design EN ISO 13849-1 -



IEC 61139-2

Edition 1.0 2022-08

INTERNATIONAL STANDARD

NORME INTERNATIONALE



**Industrial networks – Single-drop digital communication interface –
Part 2: Functional safety extensions**

**Réseaux industriels – Interface de communication numérique point à point –
Partie 2: Extensions de sécurité fonctionnelle**





THIS PUBLICATION IS COPYRIGHT PROTECTED
Copyright © 2022 IEC, Geneva, Switzerland

All rights reserved. Unless otherwise specified, no part of this publication may be reproduced or utilized in any form or by any means, electronic or mechanical, including photocopying and microfilm, without permission in writing from either IEC or IEC's member National Committee in the country of the requester. If you have any questions about IEC copyright or have an enquiry about obtaining additional rights to this publication, please contact the address below or your local IEC member National Committee for further information.

Droits de reproduction réservés. Sauf indication contraire, aucune partie de cette publication ne peut être reproduite ni utilisée sous quelque forme que ce soit et par aucun procédé, électronique ou mécanique, y compris la photocopie et les microfilms, sans l'accord écrit de l'IEC ou du Comité national de l'IEC du pays du demandeur. Si vous avez des questions sur le copyright de l'IEC ou si vous désirez obtenir des droits supplémentaires sur cette publication, utilisez les coordonnées ci-après ou contactez le Comité national de l'IEC de votre pays de résidence.

IEC Secretariat
3, rue de Varembe
CH-1211 Geneva 20
Switzerland

Tel.: +41 22 919 02 11
info@iec.ch
www.iec.ch

About the IEC

The International Electrotechnical Commission (IEC) is the leading global organization that prepares and publishes International Standards for all electrical, electronic and related technologies.

About IEC publications

The technical content of IEC publications is kept under constant review by the IEC. Please make sure that you have the latest edition, a corrigendum or an amendment might have been published.

IEC publications search - webstore.iec.ch/advsearchform

The advanced search enables to find IEC publications by a variety of criteria (reference number, text, technical committee, ...). It also gives information on projects, replaced and withdrawn publications.

IEC Just Published - webstore.iec.ch/justpublished

Stay up to date on all new IEC publications. Just Published details all new publications released. Available online and once a month by email.

IEC Customer Service Centre - webstore.iec.ch/csc

If you wish to give us your feedback on this publication or need further assistance, please contact the Customer Service Centre: sales@iec.ch.

IEC Products & Services Portal - products.iec.ch

Discover our powerful search engine and read freely all the publications previews. With a subscription you will always have access to up to date content tailored to your needs.

Electropedia - www.electropedia.org

The world's leading online dictionary on electrotechnology, containing more than 22 300 terminological entries in English and French, with equivalent terms in 19 additional languages. Also known as the International Electrotechnical Vocabulary (IEV) online.

A propos de l'IEC

La Commission Electrotechnique Internationale (IEC) est la première organisation mondiale qui élabore et publie des Normes internationales pour tout ce qui a trait à l'électricité, à l'électronique et aux technologies apparentées.

A propos des publications IEC

Le contenu technique des publications IEC est constamment revu. Veuillez vous assurer que vous possédez l'édition la plus récente, un corrigendum ou amendement peut avoir été publié.

Recherche de publications IEC -

webstore.iec.ch/advsearchform

La recherche avancée permet de trouver des publications IEC en utilisant différents critères (numéro de référence, texte, comité d'études, ...). Elle donne aussi des informations sur les projets et les publications remplacées ou retirées.

IEC Just Published - webstore.iec.ch/justpublished

Restez informé sur les nouvelles publications IEC. Just Published détaille les nouvelles publications parues. Disponible en ligne et une fois par mois par email.

Service Clients - webstore.iec.ch/csc

Si vous désirez nous donner des commentaires sur cette publication ou si vous avez des questions contactez-nous: sales@iec.ch.

IEC Products & Services Portal - products.iec.ch

Découvrez notre puissant moteur de recherche et consultez gratuitement tous les aperçus des publications. Avec un abonnement, vous aurez toujours accès à un contenu à jour adapté à vos besoins.

Electropedia - www.electropedia.org

Le premier dictionnaire d'électrotechnologie en ligne au monde, avec plus de 22 300 articles terminologiques en anglais et en français, ainsi que les termes équivalents dans 19 langues additionnelles. Egalement appelé Vocabulaire Electrotechnique International (IEV) en ligne.



IEC 61139-2

Edition 1.0 2022-08

INTERNATIONAL STANDARD

NORME INTERNATIONALE



**Industrial networks – Single-drop digital communication interface –
Part 2: Functional safety extensions**

**Réseaux industriels – Interface de communication numérique point à point –
Partie 2: Extensions de sécurité fonctionnelle**

INTERNATIONAL
ELECTROTECHNICAL
COMMISSION

COMMISSION
ELECTROTECHNIQUE
INTERNATIONALE

ICS 25.040

ISBN 978-2-8322-3946-9

**Warning! Make sure that you obtained this publication from an authorized distributor.
Attention! Veuillez vous assurer que vous avez obtenu cette publication via un distributeur agréé.**

CONTENTS

FOREWORD.....	12
INTRODUCTION.....	14
1 Scope.....	17
2 Normative references	17
3 Terms, definitions, symbols, abbreviated terms, and conventions	18
3.1 Terms and definitions.....	18
3.2 Common terms and definitions	18
3.3 Terms and definitions related to SDCI-FS	21
3.4 Symbols and abbreviated terms	23
3.5 Conventions.....	24
3.5.1 Behavioral descriptions.....	24
3.5.2 Memory and transmission octet order	25
4 Overview of SDCI-FS	25
4.1 Purpose of the technology and feature levels	25
4.1.1 Base SDCI-FS technology	25
4.1.2 From "analog" and "switching" to communication	26
4.1.3 Minimized paradigm shift from FS-DI to FS-Master	27
4.1.4 Following the SDCI paradigm (SIO vs. OSSDe)	28
4.1.5 Port class B	30
4.1.6 "USB-Master" with safety parameterization.....	31
4.1.7 Interoperability matrix of safety devices	31
4.2 Positioning within the automation hierarchy	32
4.3 Wiring, connectors, and power supply	33
4.4 Relationship to SDCI.....	33
4.5 Communication features and interfaces	34
4.6 Parameterization.....	34
4.7 Role of FS-Master and FS-Gateway.....	35
4.8 Mapping to upper-level systems.....	35
4.9 Structure of the document.....	35
5 Extensions to the Physical Layer (PL).....	35
5.1 Overview.....	35
5.2 Extensions to PL services	36
5.2.1 PL_SetMode.....	36
5.2.2 PL_Ready.....	36
5.3 Transmitter/receiver.....	37
5.3.1 Assumptions for the expansion to OSSDe.....	37
5.3.2 OSSDe specifics.....	37
5.3.3 Start-up of an FS-Device (Ready pulse).....	40
5.3.4 Electric characteristics of a receiver in FS-Device and FS-Master.....	41
5.4 Electric and dynamic characteristics of an FS-Device	41
5.5 Electric and dynamic characteristics of an FS-Master port (OSSDe)	44
5.6 FS-Master port FS-DI interface	45
5.7 Wake-up coordination	45
5.8 Fast start-up	46
5.9 Power supply	46
5.10 Medium.....	47

5.10.1	Constraints	47
5.10.2	Connectors	47
5.10.3	Cable characteristics	47
6	Extensions to SIO	47
7	Extensions to the data link layer (DL)	47
7.1	Overview	47
7.2	State machine of the FS-Master DL-mode handler	47
7.3	State machine of the FS-Device DL-mode handler	49
8	Extensions to the Master Configuration Manager (CM)	51
9	Extensions of the FS-Device	52
9.1	Principle architecture and models	52
9.1.1	FS-Device architecture	52
9.1.2	FS-Device model	53
9.2	Parameter Manager (PM)	54
9.3	Process Data Exchange (PDE)	54
9.4	Data Storage (DS)	54
9.4.1	General considerations and extensions including safety	54
9.4.2	Backup levels	55
10	Extensions of the FS-Master	55
10.1	Principle architecture	55
10.2	SMI service extensions	56
10.2.1	Overview	56
10.2.2	SMI_FSMasterAccess	58
10.2.3	SMI_SPDUIn	60
10.2.4	SMI_SPDUOut	60
10.2.5	SMI_FSPDInOut	60
10.3	ArgBlock extensions	62
10.3.1	Overview	62
10.3.2	FSMasterAccess	62
10.3.3	FSCPAAuthenticity	63
10.3.4	FSPortConfigList	63
10.3.5	FSPortStatusList	66
10.3.6	SPDUIn	67
10.3.7	SPDUOut	67
10.3.8	FSPDInOut	68
10.4	Safety Layer Manager (SLM)	69
10.4.1	Purpose	69
10.4.2	FS_PortModes	69
10.4.3	FSP parameter	69
10.5	Process Data Exchange (PDE)	73
10.6	Data Storage (DS)	74
11	Safety communication layer (SCL)	74
11.1	Functional requirements	74
11.2	Communication errors and safety measures	74
11.3	SCL services	75
11.3.1	Positioning of safety communication layers (SCL)	75
11.3.2	FS-Master SCL services	76
11.3.3	FS-Device SCL services	77

11.4	SCL protocol	79
11.4.1	Protocol phases to consider	79
11.4.2	FS-Device faults	80
11.4.3	Safety PDU (SPDU)	80
11.4.4	FS-Input and FS-Output data	81
11.4.5	Port number	81
11.4.6	Status and control	81
11.4.7	CRC signature	82
11.4.8	TADI safety considerations (informative)	83
11.4.9	Data types for SDCI-FS	84
11.5	SCL behavior	85
11.5.1	General	85
11.5.2	SCL state machine of the FS-Master	85
11.5.3	SCL state machine of the FS-Device	88
11.5.4	Sequence charts for several use cases	91
11.5.5	Monitoring of safety times	98
11.5.6	Reaction in the event of a malfunction	99
11.5.7	Start-up (communication)	101
11.6	SCL management	101
11.6.1	Parameter overview (FSP and FST)	101
11.6.2	Parameterization approaches	103
11.7	Integrity measures	104
11.7.1	IODD integrity	104
11.7.2	Tool integrity	104
11.7.3	Transmission integrity	104
11.7.4	Verification record	104
11.7.5	Authentication	105
11.7.6	Storage integrity	105
11.7.7	FS I/O data structure integrity	106
11.7.8	Technology parameter (FST) based on IODD	106
11.7.9	Technology parameter (FST) based on existing Dedicated Tool (IOPD)	107
11.8	Creation of FSP and FST parameters	108
11.9	Integration of Dedicated Tools (IOPD)	109
11.9.1	IOPD interface	109
11.9.2	Standard interfaces	109
11.9.3	Backward channel	110
11.10	Validation	111
11.11	Passivation	111
11.11.1	Motivation and means	111
11.11.2	Port selective (FS-Master)	111
11.11.3	Signal selective (FS-Terminal)	112
11.11.4	Qualifier settings in case of communication	112
11.11.5	Qualifier handling in case of OSSDe	112
11.12	SCL diagnosis	113
12	Functional safe processing (FS-P)	114
12.1	Recommendations for efficient I/O mappings	114
12.2	Embedded FS controller	114
Annex A	(normative) Extensions to parameters	115
A.1	Indices and parameters for SDCI-FS	115

A.2	Parameters in detail.....	116
A.2.1	FSP_Authenticity.....	116
A.2.2	FSP_Port.....	116
A.2.3	FSP_AuthentCRC.....	117
A.2.4	FSP_ProtVersion.....	117
A.2.5	FSP_ProtMode.....	117
A.2.6	FSP_Watchdog.....	117
A.2.7	FSP_IO_StructCRC.....	118
A.2.8	FSP_TechParCRC.....	119
A.2.9	FSP_ProtParCRC.....	119
A.2.10	FSP_VerifyRecord.....	119
A.2.11	FSP_TimeToReady.....	119
A.2.12	FSP_MinShutDownTime.....	120
A.2.13	FSP_WCDT.....	120
A.2.14	FSP_OFDT.....	120
A.2.15	FSP_ParamDescCRC.....	120
Annex B (normative)	Extensions to EventCodes.....	121
B.1	Additional FS-Device EventCodes.....	121
B.2	Additional Port EventCodes.....	121
Annex C (normative)	Extensions to Data Types.....	123
C.1	Data types for SDCI-FS.....	123
C.2	BooleanT (bit).....	123
C.3	IntegerT (16).....	124
C.4	IntegerT (32).....	124
C.5	Safety Code.....	125
Annex D (normative)	CRC generator polynomials.....	126
D.1	Overview of CRC generator polynomials.....	126
D.2	Residual error probabilities.....	126
D.3	Implementation considerations.....	128
D.3.1	Overview.....	128
D.3.2	Bit shift algorithm (16 bit).....	128
D.3.3	Lookup table (16 bit).....	128
D.3.4	Bit shift algorithm (32 bit).....	130
D.3.5	Lookup table (32 bit).....	130
D.3.6	Seed values.....	131
D.3.7	Octet order for CRC calculation.....	132
Annex E (normative)	IODD extensions.....	133
E.1	General.....	133
E.2	Schema.....	133
E.3	IODD constraints.....	133
E.3.1	General rules.....	133
E.3.2	Description of the IODD structure.....	133
E.3.3	Behavior of "Reset" SystemCommands in SDCI-FS.....	140
E.3.4	Profile Characteristic.....	141
E.3.5	ProcessDataInput and ProcessDataOutput.....	141
E.4	IODD conventions.....	141
E.4.1	Naming.....	141
E.4.2	Process Data (PD).....	141

E.4.3	IODD conventions for user interface	142
E.4.4	Master Tool features	142
E.5	Securing	142
E.5.1	General	142
E.5.2	DefaultValues for FSP	143
E.5.3	FSP_Authenticity	143
E.5.4	FSP_Protocol	143
E.5.5	FSP_IO_Description	144
E.5.6	Sample serialization for FSP_ParamDescCRC	144
E.5.7	FST and FSP parameters and Data Storage	145
E.5.8	Sample IODD of an FS-Device.....	145
Annex F (normative)	Device Tool Interface (DTI) for SDCI	156
F.1	Purpose of DTI.....	156
F.2	Base model.....	156
F.3	Invocation interface.....	157
F.3.1	Overview	157
F.3.2	Detection of Device Tool.....	158
F.3.3	Program Interface Description – PID.....	161
F.3.4	Temporary Parameter File – TPF	164
F.3.5	Temporary Backchannel File – TBF	169
F.3.6	Temporary Acknowledgment File – TAF	171
F.3.7	Invocation behavior	171
F.4	Device data objects (DDO).....	172
F.4.1	General	172
F.4.2	Structure of DDO package	173
F.5	Communication Interface	173
F.5.1	General	173
F.5.2	Principle of DTI communications.....	174
F.5.3	Gateways	175
F.5.4	Configuration of the Communication Server	175
F.5.5	Definition of the Communication Interface.....	176
F.5.6	Sequence for establishing a communication relation.....	176
F.5.7	Usage of the Communication Server in stand-alone mode	177
F.5.8	SDCI specifics	178
F.5.9	Changing communication settings.....	178
F.6	Reaction on incorrect Tool behavior.....	179
F.7	Compatibility	179
F.7.1	Schema validation	179
F.7.2	Version policy	180
F.8	Scalability	180
F.8.1	Scalability of a Device Tool.....	180
F.8.2	Scalability of a Master Tool.....	181
F.8.3	Interactions at conformance class combinations	181
F.9	Schema definitions.....	181
F.9.1	General	181
F.9.2	Schema of the PID.....	181
F.9.3	Schema of the TPF	183
F.9.4	Schema of the TBF	185
F.9.5	Schema of the TAF	186

F.9.6	Schema of DTI primitives	187
Annex G (normative)	Main scenarios of SDCI-FS	189
G.1	Overview	189
G.2	Sequence chart of commissioning	190
G.3	Sequence chart of replacement	191
G.4	Sequence chart of misconnection	192
Annex H (normative)	System requirements	193
H.1	Indicators	193
H.1.1	General	193
H.1.2	OSSDe	193
H.1.3	Safety communication	193
H.1.4	Acknowledgment request	193
H.2	Installation guidelines, electrical safety, and security	193
H.3	Safety function response time	194
H.4	Duration of demands	194
H.5	Maintenance and repair	194
H.6	Safety manual	194
Annex I (informative)	Information for test and assessment of SDCI-FS components	195
Bibliography	196
Figure 1	– Positioning of SDCI-FS in functional safety automation	14
Figure 2	– Relationship of this document to standards	16
Figure 3	– Memory and transmission octet order	25
Figure 4	– SDCI-FS communication layer model	25
Figure 5	– Port interface extensions for SDCI-FS	26
Figure 6	– Migration to SDCI-FS	27
Figure 7	– Minimized paradigm shift from FS-DI to FS-Master	28
Figure 8	– FS-Master types and feature levels	28
Figure 9	– Original pin layout of SDCI (port class A)	29
Figure 10	– Optimized OSSDe commissioning with FS-Master	30
Figure 11	– Level "d" of an FS-Master (Class B)	31
Figure 12	– Off-site configuration and parameterization	31
Figure 13	– SDCI-FS within the automation hierarchy	33
Figure 14	– The SDCI physical layer of an FS-Master (class A)	36
Figure 15	– The physical layer of an FS-Device (class A)	36
Figure 16	– Cross compatibility OSSD and OSSDe	37
Figure 17	– Principle OSSDe function	38
Figure 18	– Test pulses to detect cross connection faults	39
Figure 19	– OSSD timings	40
Figure 20	– Typical start-up of an OSSD sensor	40
Figure 21	– Start-up of an FS-Device	40
Figure 22	– Switching thresholds for FS-Device and FS-Master receivers	41
Figure 23	– Reference schematics (one OSSDe channel)	42
Figure 24	– Voltage level definitions	42
Figure 25	– Charge capability at power-up	45

Figure 26 – OSSDe input filter conflict resolution	45
Figure 27 – Start-up of an FS-Device	46
Figure 28 – Required fast start-up timings	46
Figure 29 – State machine of the FS-Master DL-mode handler	48
Figure 30 – State machine of the FS-Device DL-mode handler	50
Figure 31 – Extension to the Configuration Manager (VerifyRecord)	51
Figure 32 – Principle architecture of the FS-Device	53
Figure 33 – The FS-Device model	54
Figure 34 – Principle architecture of the FS-Master	56
Figure 35 – SMI service extensions	58
Figure 36 – FSP parameter use cases	70
Figure 37 – PDE Splitter	73
Figure 38 – PDE Composer	74
Figure 39 – Positioning of the SDCI-FS Safety Communication Layer (SCL)	76
Figure 40 – FS-Master Safety Communication Layer services	76
Figure 41 – FS-Device Safety Communication Layer services	78
Figure 42 – Protocol phases to consider	79
Figure 43 – Safety PDUs of FS-Master and FS-Device	80
Figure 44 – The 1 % share rule of IEC 61784-3:2021	83
Figure 45 – SCL state machine of the FS-Master	86
Figure 46 – SCL state machine of the FS-Device	89
Figure 47 – FS-Master and FS-Device both with power ON	92
Figure 48 – FS-Master power OFF → ON	93
Figure 49 – FS-Device with delayed SCL start	94
Figure 50 – FS-Device with power OFF and ON	95
Figure 51 – FS-Master detects CRC signature error	96
Figure 52 – FS-Device detects CRC signature error	97
Figure 53 – Monitoring of the SCL cycle time	98
Figure 54 – Parameter types and assignments	102
Figure 55 – FSCP-Host-centric system	103
Figure 56 – Structure of the FSP_VerifyRecord	105
Figure 57 – Start-up of SDCI-FS	106
Figure 58 – Securing of FST parameters via dedicated tool	107
Figure 59 – Modification of FST parameters via Device Tool	108
Figure 60 – Creation of FSP and FST parameters	109
Figure 61 – Example of a communication hierarchy	110
Figure 62 – Motivation for Port selective passivation	111
Figure 63 – Qualifier handler (communication)	112
Figure 64 – Qualifier handler (OSSDe)	112
Figure 65 – Qualifier behavior per FS-Master port	113
Figure 66 – Mapping efficiency issues	114
Figure A.1 – Instance of an FS I/O data description	118
Figure A.2 – Example FS I/O data structure with non-safety data	119

Figure A.3 – Securing of safety parameters	120
Figure C.1 – Example of a BooleanT data structure	124
Figure C.2 – Safety Code of an output message	125
Figure C.3 – Safety Code of an input message	125
Figure D.1 – CRC-16 generator polynomial.....	127
Figure D.2 – CRC-32 generator polynomial.....	127
Figure D.3 – Bit shift algorithm in "C" language (16 bit).....	128
Figure D.4 – CRC-16 signature calculation using a lookup table	128
Figure D.5 – Bit shift algorithm in "C" language (32 bit).....	130
Figure D.6 – CRC-32 signature calculation using a lookup table	130
Figure E.1 – Algorithm to build the FSP parameter CRC signatures	143
Figure F.1 – Principle of DTI invocation interface	157
Figure F.2 – Structure of the registry	158
Figure F.3 – Example of a DTI registry.....	159
Figure F.4 – Detection of a Device tool in registry.....	161
Figure F.5 – Menu for Device Tool invocation	162
Figure F.6 – Purpose of Device data objects (DDO).....	173
Figure F.7 – Communication routes between Device Tool and Device.....	174
Figure F.8 – Routing across networks and SDCI	174
Figure F.9 – Communication Server	175
Figure F.10 – Sequence chart for establishing communication	176
Figure F.11 – Create Communication Server instance.....	177
Figure F.12 – Example of a Connect Request XML document for SDCI.....	178
Figure F.13 – XML schema of the PID file	181
Figure F.14 – XML schema of the TPF	183
Figure F.15 – XML schema of a TBF	185
Figure G.1 – Commissioning with test and armed operation	191
Figure G.2 – FS-Device replacement	192
Figure G.3 – FS-Device misconnection	192
Table 1 – Operational modes of feature level "a" to "c" (port class A).....	30
Table 2 – Interoperability matrix of safety devices.....	32
Table 3 – PL_Ready	36
Table 4 – OSSD states and conditions	38
Table 5 – Cross connection faults	39
Table 6 – Electric characteristics of a receiver	41
Table 7 – Electric and dynamic characteristics of the FS-Device (OSSDe).....	43
Table 8 – Electric and dynamic characteristics of the Port interface	44
Table 9 – Cable characteristics	47
Table 10 – State transition tables of the FS-Master DL-mode handler	49
Table 11 – State transition tables of the FS-Device DL-mode handler	50
Table 12 – State transition tables of the Configuration Manager	52
Table 13 – Extension to Data Storage (DS) state machine	55

Table 14 – Data Storage Backup Levels	55
Table 15 – SMI services used for FS-Master.....	57
Table 16 – SMI_FSMasterAccess	59
Table 17 – SMI_FSPDInOut.....	61
Table 18 – ArgBlock types and ArgBlockIDs	62
Table 19 – FSMasterAccess	63
Table 20 – FSCPAuthenticity	63
Table 21 – FSPortConfigList.....	64
Table 22 – FSPortStatusList	66
Table 23 – SPDUIIn	67
Table 24 – SPDUIOut	68
Table 25 – FSPDInOut.....	68
Table 26 – Use case reference table.....	70
Table 27 – Communication errors and safety measures	75
Table 28 – SCL services of FS-Master	77
Table 29 – SCL services of FS-Device.....	78
Table 30 – Protocol phases to consider	80
Table 31 – Control and counting (Control&MCnt)	81
Table 32 – Status and counting mirror (Status&DCnt).....	81
Table 33 – MCount and DCount_i values	82
Table 34 – FS process I/O data types	84
Table 35 – Rules for the layout of values and qualifiers	84
Table 36 – Order of values and qualifier	85
Table 37 – Definition of terms used in SCL state machine of the FS-Master.....	86
Table 38 – FS-Master SCL states and transitions	87
Table 39 – Definition of terms used in SCL state machine of the FS-Device.....	89
Table 40 – FS-Device SCL states and transitions	90
Table 41 – Timing constraints	98
Table 42 – Qualifier bits "GOOD/BAD"	112
Table 43 – State transition Table for the qualifier behavior.....	113
Table A.1 – Indices for SDCI-FS	115
Table A.2 – Coding of protocol version	117
Table A.3 – Coding of protocol mode	117
Table A.4 – Generic FS I/O data structure description.....	118
Table B.1 – FS-Device SCL specific EventCodes.....	121
Table B.2 – FS-Master SCL specific EventCodes.....	122
Table C.1 – Data types for SDCI-FS	123
Table C.2 – BooleanT for SDCI-FS	123
Table C.3 – Example of BooleanT within a RecordT.....	123
Table C.4 – IntegerT(16).....	124
Table C.5 – IntegerT(16) coding	124
Table C.6 – IntegerT(32).....	125
Table C.7 – IntegerT(32) coding	125

Table D.1 – CRC generator polynomials for SDCI-FS	126
Table D.2 – Definition of variables used in Figure D.3.....	128
Table D.3 – Definition of variables used in Figure D.4.....	129
Table D.4 – Lookup Table for CRC-16 signature calculation	129
Table D.5 – Definition of variables used in Figure D.5.....	130
Table D.6 – Definition of variables used in Figure D.4.....	130
Table D.7 – Lookup Table for CRC-32 signature calculation	131
Table E.1 – Specific behavior of FS-Device "Reset" SystemCommands.....	141
Table E.2 – User actions to replace DefaultValues.....	143
Table E.3 – RecordItems of FSP_Protocol where allowed values shall be serialized	144
Table E.4 – Sample serialization for FSP_ParamDescCRC.....	144
Table F.1 – Description of PID file elements	162
Table F.2 – Elements of a TPF	165
Table F.3 – Elements of the TBF.....	170
Table F.4 – Elements of the TAF.....	171
Table F.5 – Invocation cases and behaviors	172
Table F.6 – Communication Schema mapping	178
Table F.7 – Reaction on incorrect Tool behavior	179
Table F.8 – DTI conformance classes	180
Table F.9 – DTI feature levels of Device Tools.....	180
Table F.10 – Interactions at conformance class combinations	181
Table G.1 – Main scenarios of SDCI-FS.....	189

INTERNATIONAL ELECTROTECHNICAL COMMISSION

**INDUSTRIAL NETWORKS –
SINGLE-DROP DIGITAL COMMUNICATION INTERFACE –**
Part 2: Functional safety extensions**FOREWORD**

- 1) The International Electrotechnical Commission (IEC) is a worldwide organization for standardization comprising all national electrotechnical committees (IEC National Committees). The object of IEC is to promote international co-operation on all questions concerning standardization in the electrical and electronic fields. To this end and in addition to other activities, IEC publishes International Standards, Technical Specifications, Technical Reports, Publicly Available Specifications (PAS) and Guides (hereafter referred to as "IEC Publication(s)"). Their preparation is entrusted to technical committees; any IEC National Committee interested in the subject dealt with may participate in this preparatory work. International, governmental and non-governmental organizations liaising with the IEC also participate in this preparation. IEC collaborates closely with the International Organization for Standardization (ISO) in accordance with conditions determined by agreement between the two organizations.
- 2) The formal decisions or agreements of IEC on technical matters express, as nearly as possible, an international consensus of opinion on the relevant subjects since each technical committee has representation from all interested IEC National Committees.
- 3) IEC Publications have the form of recommendations for international use and are accepted by IEC National Committees in that sense. While all reasonable efforts are made to ensure that the technical content of IEC Publications is accurate, IEC cannot be held responsible for the way in which they are used or for any misinterpretation by any end user.
- 4) In order to promote international uniformity, IEC National Committees undertake to apply IEC Publications transparently to the maximum extent possible in their national and regional publications. Any divergence between any IEC Publication and the corresponding national or regional publication shall be clearly indicated in the latter.
- 5) IEC itself does not provide any attestation of conformity. Independent certification bodies provide conformity assessment services and, in some areas, access to IEC marks of conformity. IEC is not responsible for any services carried out by independent certification bodies.
- 6) All users should ensure that they have the latest edition of this publication.
- 7) No liability shall attach to IEC or its directors, employees, servants or agents including individual experts and members of its technical committees and IEC National Committees for any personal injury, property damage or other damage of any nature whatsoever, whether direct or indirect, or for costs (including legal fees) and expenses arising out of the publication, use of, or reliance upon, this IEC Publication or any other IEC Publications.
- 8) Attention is drawn to the Normative references cited in this publication. Use of the referenced publications is indispensable for the correct application of this publication.
- 9) Attention is drawn to the possibility that some of the elements of this IEC Publication may be the subject of patent rights. IEC shall not be held responsible for identifying any or all such patent rights.

IEC 61139-2 has been prepared by subcommittee 65C: Industrial networks, of IEC technical committee TC65: Industrial-process measurement, control and automation. It is an International Standard.

The text of this International Standard is based on the following documents:

Draft	Report on voting
65C/1168/FDIS	65C/1174/RVD

Full information on the voting for its approval can be found in the report on voting indicated in the above table.

The language used for the development of this International Standard is English.

This document was drafted in accordance with ISO/IEC Directives, Part 2, and developed in accordance with ISO/IEC Directives, Part 1 and ISO/IEC Directives, IEC Supplement, available at www.iec.ch/members_experts/refdocs. The main document types developed by IEC are described in greater detail at www.iec.ch/standardsdev/publications.

A list of all parts in the IEC 61139 series, published under the general title *Industrial networks – Single-drop digital communication interface*, can be found on the IEC website.

The committee has decided that the contents of this document will remain unchanged until the stability date indicated on the IEC website under webstore.iec.ch in the data related to the specific document. At this date, the document will be

- reconfirmed,
- withdrawn,
- replaced by a revised edition, or
- amended.

IMPORTANT – The "colour inside" logo on the cover page of this document indicates that it contains colours which are considered to be useful for the correct understanding of its contents. Users should therefore print this document using a colour printer.

INTRODUCTION

The base technology of IO-Link™¹ is subject matter of the international standard IEC 61131-9 being part of a series of standards on programmable controllers and the associated peripherals such as remote I/O (RIO).

It specifies a single-drop digital communication interface technology – named SDCI, which extends the traditional switching input and output interfaces as defined in IEC 61131-2 towards a point-to-point communication link using coded switching. This technology enables the cyclic exchange of digital input and output process data between a Master and its associated Devices (sensors, actuators, I/O terminals, etc.). The Master can be part of a fieldbus communication system or any stand-alone processing unit. The technology also enables the acyclic transfer of parameters to Devices and the propagation of diagnosis information from the Devices to the upper-level automation system (controller, host) via the Master.

Physical topology is point-to-point from each Device to the Master using 3 wires over distances up to 20 m. The SDCI physical interface is backward compatible with the usual 24 V I/O signalling specified in IEC 61131-2 and supports three transmission rates of 4,8 kbit/s, 38,4 kbit/s and 230,4 kbit/s are supported.

The main advantages of the SDCI technology are:

- dual use of either switching signals (DI/DO) or coded switching communication respectively,
- traditional switching sensors and actuators now providing alternatively single drop digital communication within the same Device,
- one thin, robust, very flexible cable without shielding for power supply and signalling,
- lowest-cost digital communication down to the lowest end sensors and actuators.

The functional safety variant of SDCI is called SDCI-FS. Figure 1 shows an example positioning of SDCI-FS in functional safety automation.

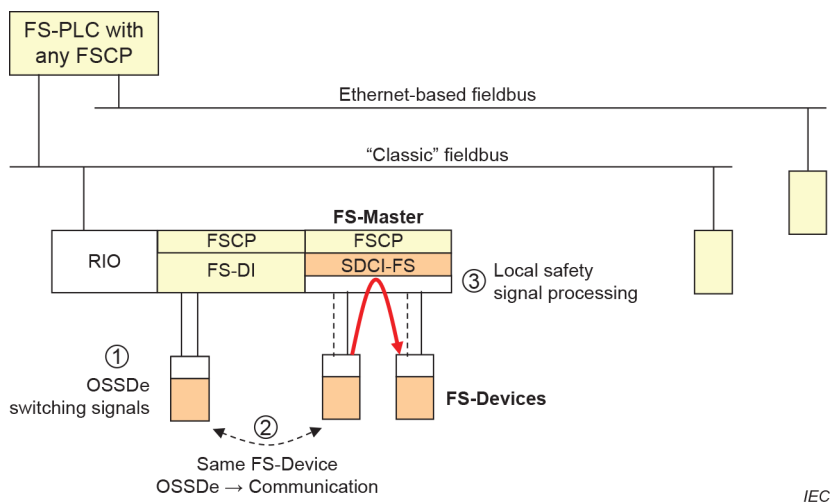

Figure 1 – Positioning of SDCI-FS in functional safety automation

¹ IO-Link™ is a trade name of the "IO-Link Community". This information is given for the convenience of users of this specification and does not constitute an endorsement by the IO-Link Community of the trade name holder or any of its products. Compliance to this document does not require use of the registered logos for IO-Link™. Use of the registered logos for IO-Link™ requires permission of the "IO-Link Community".

In this example, a remote I/O is connected to a functional safety programmable controller using one of the FSCPs of the IEC 61784-3 series [1]² to communicate with an FS-DI module and a gateway to an SDCI-FS FS-Master. FS-Devices with OSSDe can be connected to FS-DIs or FS-Masters. All FS-Devices can communicate with any FS-Master using the SDCI-FS protocol regardless of the upper-level FSCP-system. The same is true for safety actuators (FS-Devices) such as drives with integrated safety. This means the largest component commonality ① for sensors and actuators similar to the DI and DO interfaces standardized within IEC 61131-2.

Safety sensors with OSSDe interfaces – equipped with SDCI-FS communication – can be parameterized via auxiliary tools such as "USB-Masters", then connected to an FS-DI and operated in OSSDe mode. They also can be operated in OSSDe mode on an FS-Master that supports OSSDe. In case these safety sensors are equipped with SDCI-FS communication in addition, they can be operated in both modes ②, either OSSDe or SDCI-FS. This corresponds to the SDCI SIO paradigm.

The concept of SDCI-FS allows for local safety signal processing if the gateway/FS-Master provides a local safety controller ③.

This document provides the necessary extensions to IEC 61131-9 for functional safety communication including standardization of OSSDe and parameterization within the domain of safety for machinery. Figure 2 shows its relationships to international fieldbus and safety standards as well as to relevant specifications (see Clause 2 and bibliography). Any functional safety starts with risk assessment and risk reduction (ISO 12100). One possibility of risk reduction is the usage of electrical or electronic control systems. For the design of those, standards such as IEC 61508, IEC 62061, and ISO 13849 can be used. Environmental conditions such as EMC are covered by for example IEC 61000-6-7. Further aspects are installations and security issues. A number of product standards such as IEC 60947-5-3 and ISO 14119 complement the generic or sector standards.

² Numbers in square brackets refer to the Bibliography.

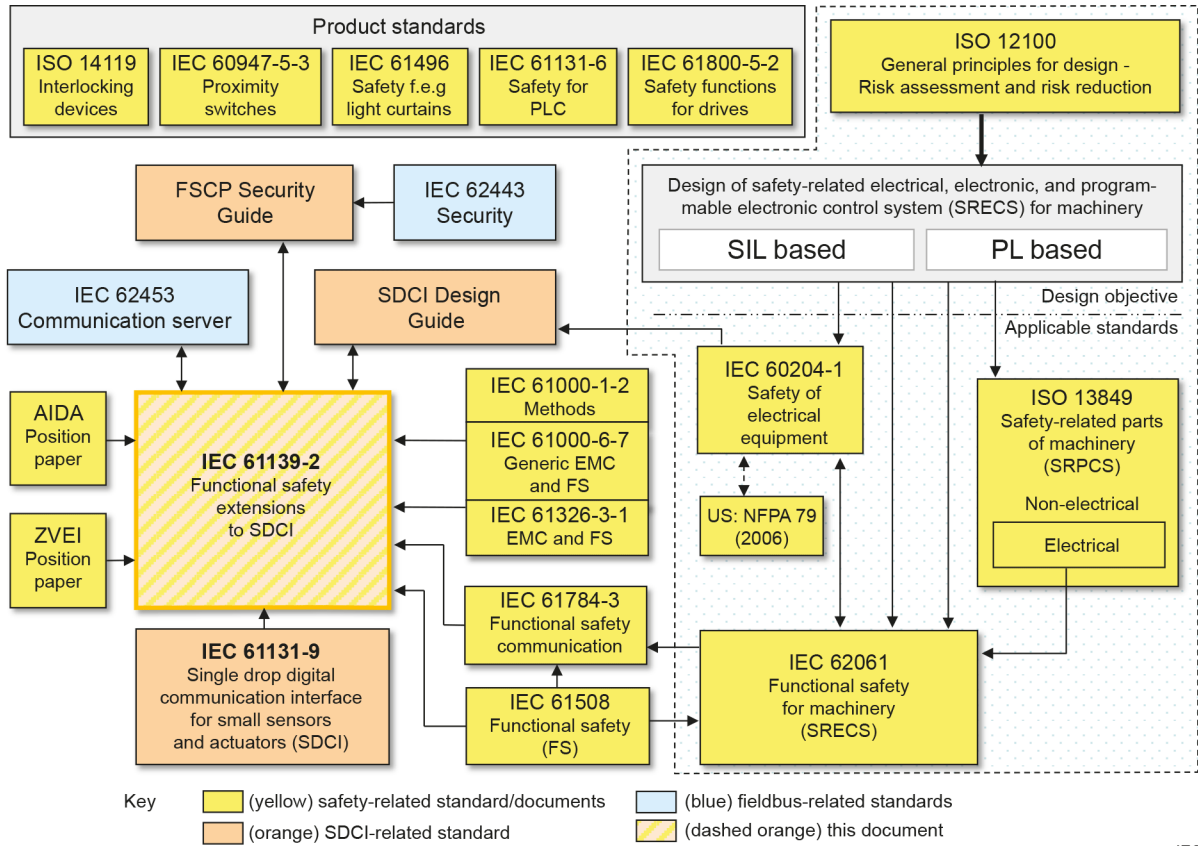

IEC

Figure 2 – Relationship of this document to standards

SDCI-FS can be used for functional safety applications according to IEC 62061 and IEC 61508 up to SIL3 and/or according to ISO 13849 up to PLe.

INDUSTRIAL NETWORKS – SINGLE-DROP DIGITAL COMMUNICATION INTERFACE –

Part 2: Functional safety extensions

1 Scope

This part of IEC 61139 specifies the extensions to SDCI in IEC 61131-9 for functional safety. This comprises:

- a standardized OSSDe interface for redundant switching signals based on IEC 61131-2,
- minor modifications/extensions to state machines of SDCI to support the safety operations,
- a lean functional safety communication protocol on top of the standard SDCI communication which is a black channel according to IEC 61784-3:2021,
- protocol management functions for configuration, parameterization, and commissioning,
- IODD extensions for functional safety,
- a Device tool interface to support Dedicated Tools according to functional safety standards.

This document does not cover:

- communication interfaces or systems including multi-point or multi-drop linkages,
- communication interfaces or systems including multi-channel or encrypted linkages,
- wireless communication interfaces or systems,
- integration of SDCI-FS into upper-level systems such as fieldbuses/FSCPs.

2 Normative references

The following documents are referred to in the text in such a way that some or all of their content constitutes requirements of this document. For dated references, only the edition cited applies. For undated references, the latest edition of the referenced document (including any amendments) applies.

IEC 60204-1, *Safety of machinery – Electrical equipment of machines – Part 1: General requirements*

IEC 61010-2-201, *Safety requirements for electrical equipment for measurement, control and laboratory use – Part 2-201: Particular requirements for control equipment*

IEC 61131-2, *Industrial-process measurement and control – Programmable controllers – Part 2: Equipment requirements and tests*

IEC 61131-9:—³, *Programmable controllers – Part 9: Single-drop digital communication interface for small sensors and actuators (SDCI)*

IEC 61496-1, *Safety of machinery – Electro-sensitive protective equipment – Part 1: General requirements and tests*

³ Under preparation. Stage at the time of publication: IEC/CFDIS 61131-9:2022.

IEC 61508-3, *Functional safety of electrical/electronic/programmable electronic safety-related systems – Part 3: Software requirements*

IEC 61784-3:2021, *Industrial communication networks – Profiles – Part 3: Functional safety fieldbuses – General rules and profile definitions*

IEC 62061, *Safety of machinery – Functional safety of safety-related control systems*

IEC 62443 (all parts), *Security for industrial automation and control systems*

ISO 639-2, *Codes for the representation of names of languages – Part 2: Alpha-3 code*

ISO 639-3, *Codes for the representation of names of languages – Part 3: Part 3: Alpha-3 code for comprehensive coverage of languages*

ISO 13849-1, *Safety of machinery – Safety-related parts of control systems – Part 1: General principles for design*

koniec náhľadu – text ďalej pokračuje v platenej verzii STN