

STN	Cisterny na prepravu nebezpečných látok Digitálne rozhranie na prenos dát medzi cisternovým vozidlom a stacionárnym zariadením Časť 1: Špecifikácia protokolu Riadiace údaje, merané údaje a záznam udalostí	STN EN 15969-1 69 8524
------------	---	--

Tanks for transport of dangerous goods - Digital interface for the data transfer between tank vehicle and with stationary facilities - Part 1: Protocol specification - Control, measurement and event data

Táto norma obsahuje anglickú verziu európskej normy.
This standard includes the English version of the European Standard.

Táto norma bola oznámená vo Vestníku ÚNMS SR č. 01/23

Obsahuje: EN 15969-1:2022

Oznámením tejto normy sa ruší
STN EN 15969-1 (69 8524) z júna 2018

EUROPEAN STANDARD

EN 15969-1

NORME EUROPÉENNE

EUROPÄISCHE NORM

October 2022

ICS 13.300; 23.020.10; 35.240.60

Supersedes EN 15969-1:2017

English Version

**Tanks for transport of dangerous goods - Digital interface
for the data transfer between tank vehicle and with
stationary facilities - Part 1: Protocol specification -
Control, measurement and event data**

Citernes destinées au transport de matières dangereuses - Interface numérique pour le transfert de données entre des véhicules-citernes et des installations fixes - Partie 1 : Spécifications du protocole - Contrôle, données de mesure et d'événements

Tanks für die Beförderung gefährlicher Güter - Digitale Schnittstelle für den Datenaustausch zwischen Tankfahrzeugen und stationären Einrichtungen - Teil 1: Protokollspezifikation - Steuerungs-, Mess- und Ereignisdaten

This European Standard was approved by CEN on 19 September 2022.

CEN members are bound to comply with the CEN/CENELEC Internal Regulations which stipulate the conditions for giving this European Standard the status of a national standard without any alteration. Up-to-date lists and bibliographical references concerning such national standards may be obtained on application to the CEN-CENELEC Management Centre or to any CEN member.

This European Standard exists in three official versions (English, French, German). A version in any other language made by translation under the responsibility of a CEN member into its own language and notified to the CEN-CENELEC Management Centre has the same status as the official versions.

CEN members are the national standards bodies of Austria, Belgium, Bulgaria, Croatia, Cyprus, Czech Republic, Denmark, Estonia, Finland, France, Germany, Greece, Hungary, Iceland, Ireland, Italy, Latvia, Lithuania, Luxembourg, Malta, Netherlands, Norway, Poland, Portugal, Republic of North Macedonia, Romania, Serbia, Slovakia, Slovenia, Spain, Sweden, Switzerland, Türkiye and United Kingdom.



EUROPEAN COMMITTEE FOR STANDARDIZATION
COMITÉ EUROPÉEN DE NORMALISATION
EUROPÄISCHES KOMITEE FÜR NORMUNG

CEN-CENELEC Management Centre: Rue de la Science 23, B-1040 Brussels

EN 15969-1:2022 (E)**Contents**

Page

European foreword.....	4
Introduction	6
1 Scope.....	7
2 Normative references.....	7
3 Terms and definitions, abbreviations and conventions	7
3.1 Terms and definitions	7
3.2 Abbreviations	9
3.3 Conventions.....	9
4 Hardware interface	10
5 Basic protocol layer.....	10
5.1 FTL-frame (frame)	10
5.2 Frame flow (handshake)	11
5.3 Delay and timeout.....	16
5.4 CRC16 Checksum	16
6 Data protocol layer (FTL-data protocol)	16
6.1 Client (OBC) and server (TVE).....	16
6.2 Syntax of data in datagrams	17
6.3 Nodes, subnodes, variables	17
6.4 Format identifiers.....	17
6.5 Types of variable values	20
6.6 Kinds of nodes	21
7 FTL-Data	22
7.1 General.....	22
7.2 Record and field types	22
7.3 Systemwide variables (subnode SYSTEM)	23
7.4 Variables related to global positioning system (subnode GPS)	27
7.5 Accessing a printer on TVE-side (subnode PRN)	27
7.6 Compartment information (subnode COMP).....	30
7.7 Notification about changes (subnode NOTIFY)	32
7.8 Information about driver (subnode DRIVER).....	33
7.9 Information about the vehicle (variable VEHICLE_ID)	34
7.10 Information about current operation (subnode OPERATION).....	34
7.11 Access to filesystem on TVE (subnode FS)	36
7.12 Auxiliary (subnode AUX).....	41
7.13 Order management (subnode ORDER)	42
7.14 Goods and service database (subnode PRODUCT).....	46
7.15 FTL—logfile (subnodes LOG)	49
7.16 Required variables	81
7.17 NAK ID	82
8 Routing for multiple TVE.....	83
8.1 Purpose	83
8.2 Routing solution	83
8.3 Routing example.....	84
9 Communication with office.....	84

9.1	General	84
9.2	Simple file transfer	85
9.3	FTL over TCP/IP	87
10	Communication Examples	89
10.1	Examples for Basic Protocol Layer level	89
10.2	Examples for data protocol layer	91
	Annex A (normative) Node tree	94
	Annex B (normative) Test FTL	95
B.1	Overview	95
B.2	Basic Protocol Layer	95
B.2.1	Frame Tests	95
B.2.2	CRC-error	96
B.2.3	Delay and Timeout	96
B.3	Data Protocol Layer	96
B.3.1	Test of Toggling	96
B.3.2	Test of the FTL data layer	98
B.3.3	Test of the required FTL nodes	98
B.3.4	Optional System Subnodes	101
B.3.5	Optional Node Prn	103
B.3.6	Node Comp	105
B.4	Application Layer	111
B.4.1	Test of the L-File	111
B.4.2	Test of the LH-File	111
B.4.3	Test for the Filling of the NodeList	111
B.4.4	Sequence Test	112
	Bibliography	114

EN 15969-1:2022 (E)

European foreword

This document (EN 15969-1:2022) has been prepared by Technical Committee CEN/TC 296 “Tanks for the transport of dangerous goods”, the secretariat of which is held by AFNOR.

This European Standard shall be given the status of a national standard, either by publication of an identical text or by endorsement, at the latest by April 2023, and conflicting national standards shall be withdrawn at the latest by April 2023.

Attention is drawn to the possibility that some of the elements of this document may be the subject of patent rights. CEN shall not be held responsible for identifying any or all such patent rights.

This document supersedes EN 15969-1:2017.

In comparison with the previous edition, the following technical modifications have been made:

- Figure 11 corrected;
- Subclause 7.3.11 “Trailer coupled (variable TRAILER)” added;
- Subclause 7.5.9 “Duplicate print (DUPLICATE)” added;
- Table 55 “Fields of records of ORDER.PLAN” Index 19 to 21 added;
- In subclause 7.13.4 Value V for planned transaction in process and unplanned transaction in process added;
- Table 67 “L file record types” in Index L1137 Bit 3 added;
- Table 67 “L file record types” Index L1147 added;
- Table 67 “L file record types” Index L1205 added;
- Table 67 “L file record types” in Index L2002 event codes 80 to > 100 added;
- Table 67 “L file record types” Index L4007 and L4008 added;
- Table 67 “L file record types” in Index L4206 delivery path 25 to 36 and 80 to 86 added;
- Table 67 “L file record types” Index L4207 and L4208 added;
- Table 67 “L file record types” Index 94 Diagnose added;
- Node tree in Figure A.1 revised.

EN 15969, *Tanks for transport of dangerous goods — Digital interface for the data transfer between tank vehicle and with stationary facilities*, consists of 2 parts:

- *Part 1: Protocol specification — Control, measurement and event data;*
- *Part 2: Commercial and logistic data.*

This document forms part of a coherent standards programme comprising the following standards:

- EN 13616-1, *Overfill prevention devices for static tanks for liquid fuels — Part 1: Overfill prevention devices with closure device;*
- EN 13616-2, *Overfill prevention devices for static tanks for liquid fuels — Part 2: Overfill prevention devices without a closure device;*
- EN 13922, *Tanks for transport of dangerous goods — Service equipment for tanks — Overfill prevention systems for liquid fuels;*
- EN 14116, *Tanks for transport of dangerous goods — Digital interface for product recognition devices for liquid fuels;*
- EN 15207, *Tanks for the transport of dangerous goods — Plug/socket connection and supply characteristics for service equipment in hazardous areas with 24 V nominal supply voltage;*
- EN 15208, *Tanks for transport of dangerous goods — Sealed parcel delivery systems — Working principles and interface specifications;*
- EN 15969-2, *Tanks for transport of dangerous goods — Digital interface for the data transfer between tank vehicle and with stationary facilities — Part 2: Commercial and logistic data.*

Any feedback and questions on this document should be directed to the users' national standards body. A complete listing of these bodies can be found on the CEN website.

According to the CEN-CENELEC Internal Regulations, the national standards organisations of the following countries are bound to implement this European Standard: Austria, Belgium, Bulgaria, Croatia, Cyprus, Czech Republic, Denmark, Estonia, Finland, France, Germany, Greece, Hungary, Iceland, Ireland, Italy, Latvia, Lithuania, Luxembourg, Malta, Netherlands, Norway, Poland, Portugal, Republic of North Macedonia, Romania, Serbia, Slovakia, Slovenia, Spain, Sweden, Switzerland, Türkiye and the United Kingdom.

EN 15969-1:2022 (E)

Introduction

FTL is an acronym for **Fuel Truck Link**, the interface between electronic system(s) on board of a tank vehicle (tank-vehicle-equipment) and any external computer, e.g. an on-board-computer installed in the driver's cabin; for illustration see Figure 1.

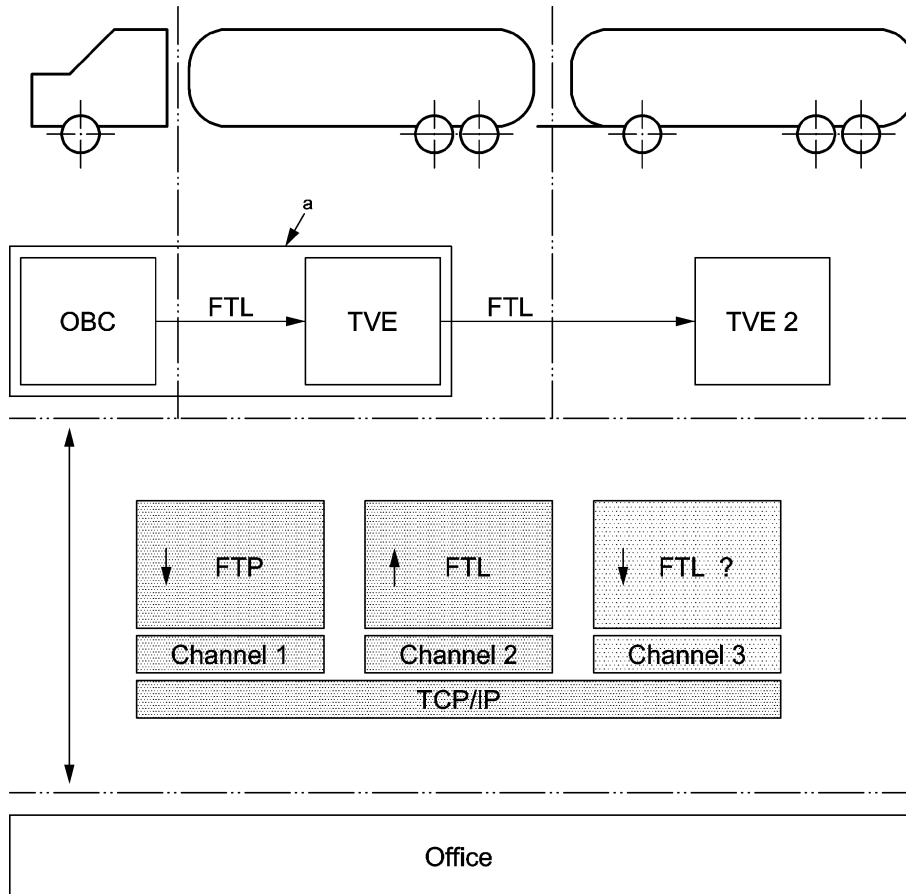

Key

→ direction of communication (client → server)

a may be either two independent units or one single unit which incorporates both functions OBC and TVE

Figure 1

1 Scope

This document specifies data protocols and data format for the communication between electronic equipment (TVE), on-board computer (OBC) of the tank vehicle and stationary equipment.

This document specifies the basic protocol FTL used in the communication (basic protocol layer), the format and structure of FTL-data to be transmitted (data protocol layer) and describes the content of the FTL-data.

This data protocol can be used for other application e.g. between stationary tank equipment and offices.

2 Normative references

The following documents are referred to in the text in such a way that some or all of their content constitutes requirements of this document. For dated references, only the edition cited applies. For undated references, the latest edition of the referenced document (including any amendments) applies.

DIN 51757:2011, *Testing of mineral oils and related materials — Determination of density*

EN 13616-2, *Overfill prevention devices for static tanks for liquid fuels — Part 2: Overfill prevention devices without a closure device*

EN 13922, *Tanks for transport of dangerous goods — Service equipment for tanks — Overfill prevention systems for liquid fuels*

EN 14116:2012+A2:2018, *Tanks for transport of dangerous goods — Digital interface for product recognition devices for liquid fuels*

EN 15208:2014, *Tanks for transport of dangerous goods — Sealed parcel delivery systems — Working principles and interface specifications*

ISO 639-1, *Codes for the representation of names of languages — Part 1: Alpha-2 code*

koniec náhľadu – text ďalej pokračuje v platenej verzii STN