

STN	Čistiarne odpadových vôd Časť 4: Primárne usadzovanie	STN EN 12255-4 75 6410
------------	--	--

Wastewater treatment plants - Part 4: Primary treatment

Táto norma obsahuje anglickú verziu európskej normy.
This standard includes the English version of the European Standard.

Táto norma bola oznámená vo Vestníku ÚNMS SR č. 05/23

Obsahuje: EN 12255-4:2023

Oznámením tejto normy sa ruší
STN EN 12255-4 (75 6410) zo septembra 2003

EUROPEAN STANDARD

EN 12255-4

NORME EUROPÉENNE

EUROPÄISCHE NORM

March 2023

ICS 13.060.30

Supersedes EN 12255-4:2002

English Version

Wastewater treatment plants - Part 4: Primary treatment

Stations d'épuration - Partie 4 : Traitement primaire

Kläranlagen - Teil 4: Vorklärung

This European Standard was approved by CEN on 9 January 2023.

CEN members are bound to comply with the CEN/CENELEC Internal Regulations which stipulate the conditions for giving this European Standard the status of a national standard without any alteration. Up-to-date lists and bibliographical references concerning such national standards may be obtained on application to the CEN-CENELEC Management Centre or to any CEN member.

This European Standard exists in three official versions (English, French, German). A version in any other language made by translation under the responsibility of a CEN member into its own language and notified to the CEN-CENELEC Management Centre has the same status as the official versions.

CEN members are the national standards bodies of Austria, Belgium, Bulgaria, Croatia, Cyprus, Czech Republic, Denmark, Estonia, Finland, France, Germany, Greece, Hungary, Iceland, Ireland, Italy, Latvia, Lithuania, Luxembourg, Malta, Netherlands, Norway, Poland, Portugal, Republic of North Macedonia, Romania, Serbia, Slovakia, Slovenia, Spain, Sweden, Switzerland, Türkiye and United Kingdom.



EUROPEAN COMMITTEE FOR STANDARDIZATION
COMITÉ EUROPÉEN DE NORMALISATION
EUROPÄISCHES KOMITEE FÜR NORMUNG

CEN-CENELEC Management Centre: Rue de la Science 23, B-1040 Brussels

EN 12255-4:2023 (E)

Contents		Page
European foreword		3
Introduction		5
1	Scope	6
2	Normative references	6
3	Terms and definitions	6
4	Symbols and abbreviations	7
5	Requirements	7
5.1	General	7
5.2	Planning	8
5.2.1	Required Data and Information	8
5.2.2	Advantages and Disadvantages of Primary Treatment Systems	10
5.2.3	Performance	11
5.3	Design	12
5.3.1	General	12
5.3.2	Specifications	12
5.3.3	Required Capacity	12
5.3.4	Systems for primary treatment	12
5.3.5	Materials	17
5.3.6	Control and Automation	17
5.3.7	Operation and Maintenance	17
5.3.8	Health and Safety	17
Annex A (informative) Illustrations of typical clarifiers		18
Annex B (normative) Dimensions and tolerances for the structures of clarifiers		26
Bibliography		27

European foreword

This document (EN 12255-4:2023) has been prepared by Technical Committee CEN/TC 165 “Waste water engineering”, the secretariat of which is held by DIN.

This European Standard shall be given the status of a national standard, either by publication of an identical text or by endorsement, at the latest by September 2023, and conflicting national standards shall be withdrawn at the latest by September 2023.

Attention is drawn to the possibility that some of the elements of this document may be the subject of patent rights. CEN shall not be held responsible for identifying any or all such patent rights.

This document supersedes EN 12255-4:2002.

It is the fourth part prepared by the Working Group CEN/TC 165/WG 40 relating to the general requirements and processes for treatment plants for a total number of inhabitants and population equivalents (PT) over 50.

The EN 12255 series, *Wastewater treatment plants*, consists of the following parts:

- *Part 1: General construction principles*
- *Part 2: Storm management systems*
- *Part 3: Preliminary treatment*
- *Part 4: Primary treatment*
- *Part 5: Lagooning processes*
- *Part 6: Activated sludge process*
- *Part 7: Biological fixed-film reactors*
- *Part 8: Sludge treatment and storage*
- *Part 9: Odour control and ventilation*
- *Part 10: Safety principles*
- *Part 11: General data required*
- *Part 12: Control and automation*
- *Part 13: Chemical treatment — Treatment of wastewater by precipitation/flocculation*
- *Part 14: Disinfection*
- *Part 15: Measurement of the oxygen transfer in clean water in aeration tanks of activated sludge plants*
- *Part 16: Physical (mechanical) filtration*

EN 12255-4:2023 (E)

NOTE 1 Part 2 is under preparation.

NOTE 2 For requirements on pumping installations at wastewater treatment plants, see EN 752, *Drain and sewer systems outside buildings — Sewer system management* and EN 16932 (all parts), *Drain and sewer systems outside buildings — Pumping systems*.

Any feedback and questions on this document should be directed to the users' national standards body. A complete listing of these bodies can be found on the CEN website.

According to the CEN-CENELEC Internal Regulations, the national standards organisations of the following countries are bound to implement this European Standard: Austria, Belgium, Bulgaria, Croatia, Cyprus, Czech Republic, Denmark, Estonia, Finland, France, Germany, Greece, Hungary, Iceland, Ireland, Italy, Latvia, Lithuania, Luxembourg, Malta, Netherlands, Norway, Poland, Portugal, Republic of North Macedonia, Romania, Serbia, Slovakia, Slovenia, Spain, Sweden, Switzerland, Türkiye and the United Kingdom.

Introduction

Differences in wastewater treatment throughout Europe have led to a variety of systems being developed. This document gives fundamental information about the systems; this document has not attempted to specify all available systems. A generic arrangement of wastewater treatment plants is illustrated below in Figure 1:

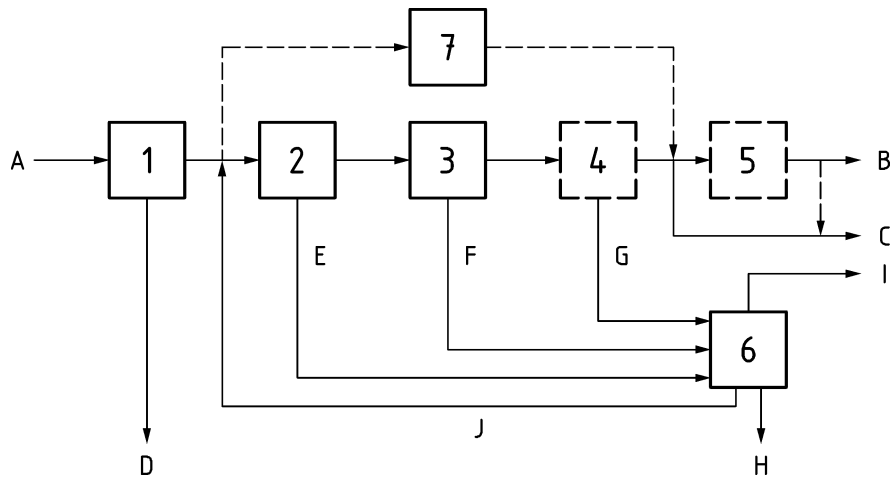

Key

- 1 preliminary treatment
- 2 primary treatment
- 3 secondary treatment
- 4 tertiary treatment
- 5 additional treatment (e.g. disinfection or removal of micropollutants)
- 6 sludge treatment
- 7 lagoons (as an alternative)
- A raw wastewater
- B effluent for re-use (e.g. irrigation)
- C discharged effluent
- D screenings and grit
- E primary sludge
- F secondary sludge
- G tertiary sludge
- H stabilized sludge
- I digester gas
- J returned water from dewatering

Figure 1 — Schematic diagram of wastewater treatment plants

Detailed information additional to that contained in this document can be obtained by referring to the bibliography.

The primary application is for wastewater treatment plants designed for the treatment of domestic and municipal wastewater.

EN 12255-4:2023 (E)**1 Scope**

This document specifies the design requirements for plant and equipment to remove solids, other than screenings and grit, from raw wastewater, at wastewater treatment plants for over 50 PT.

It includes primary treatment with sedimentation, fine screens and micro-screens.

NOTE 1 The removal of screenings and grit is covered in EN 12255-3.

NOTE 2 Dissolved air flotation (DAF) is not covered in detail in this document because it is not commonly used for primary treatment in municipal wastewater treatment plants. It can be used for primary treatment of industrial wastewater, but then the design is specific to the application.

2 Normative references

The following documents are referred to in the text in such a way that some or all of their content constitutes requirements of this document. For dated references, only the edition cited applies. For undated references, the latest edition of the referenced document (including any amendments) applies.

EN 12255-1, *Wastewater treatment plants - Part 1: General construction principles*

EN 12255-10, *Wastewater treatment plants - Part 10: Safety principles*

EN 16323:2014, *Glossary of wastewater engineering terms*

koniec náhľadu – text ďalej pokračuje v platenej verzii STN