

<b>STN</b>	<b>Konektory pre elektrické a elektronické zariadenia</b> <b>Požiadavky na výrobok</b> <b>Časť 2-115: Podrobná špecifikácia 12-pólových tienených konektorov s menovitým prúdom 2 A a kovovým puzdrom IP65/IP67 s push-pull zámkom</b>	<b>STN</b> <b>EN IEC</b> <b>61076-2-115</b>  35 4621
------------	--	--

Connectors for electrical and electronic equipment - Product requirements - Part 2-115: Circular connectors - Detail specification for 12-pole shielded connectors with 2 A rated current and IP65/IP67 metal housing with push-pull locking

Táto norma obsahuje anglickú verziu európskej normy.  
This standard includes the English version of the European Standard.

Táto norma bola oznámená vo Vestníku ÚNMS SR č. 08/23

Obsahuje: EN IEC 61076-2-115:2023, IEC 61076-2-115:2023

**137334**

EUROPEAN STANDARD

**EN IEC 61076-2-115**

NORME EUROPÉENNE

EUROPÄISCHE NORM

June 2023

ICS 31.220.10

English Version

**Connectors for electrical and electronic equipment - Product requirements - Part 2-115: Circular connectors - Detail specification for 12-pole shielded connectors with 2 A rated current and IP65/IP67 metal housing with push-pull locking (IEC 61076-2-115:2023)**

Connecteurs pour équipements électriques et électroniques  
- Exigences de produit - Partie 2-115: Connecteurs  
circulaires - Spécification particulière relative aux  
connecteurs blindés à 12 pôles avec un courant assigné de  
2 A et un boîtier métallique IP65/IP67 équipé d'un  
mécanisme de verrouillage de type pousser-tirer  
(IEC 61076-2-115:2023)

Steckverbinder für elektrische und elektronische  
Einrichtungen - Produktanforderungen - Teil 2-115:  
Rundsteckverbinder - Einzelspezifikation für 12-polige  
Steckverbinder mit 2 A Nennstrom und Push-Pull-  
Verriegelung IP65/IP67 Metallgehäuse  
(IEC 61076-2-115:2023)

This European Standard was approved by CENELEC on 2023-06-27. CENELEC members are bound to comply with the CEN/CENELEC Internal Regulations which stipulate the conditions for giving this European Standard the status of a national standard without any alteration.

Up-to-date lists and bibliographical references concerning such national standards may be obtained on application to the CEN-CENELEC Management Centre or to any CENELEC member.

This European Standard exists in three official versions (English, French, German). A version in any other language made by translation under the responsibility of a CENELEC member into its own language and notified to the CEN-CENELEC Management Centre has the same status as the official versions.

CENELEC members are the national electrotechnical committees of Austria, Belgium, Bulgaria, Croatia, Cyprus, the Czech Republic, Denmark, Estonia, Finland, France, Germany, Greece, Hungary, Iceland, Ireland, Italy, Latvia, Lithuania, Luxembourg, Malta, the Netherlands, Norway, Poland, Portugal, Republic of North Macedonia, Romania, Serbia, Slovakia, Slovenia, Spain, Sweden, Switzerland, Türkiye and the United Kingdom.



European Committee for Electrotechnical Standardization  
Comité Européen de Normalisation Electrotechnique  
Europäisches Komitee für Elektrotechnische Normung

**CEN-CENELEC Management Centre: Rue de la Science 23, B-1040 Brussels**

**EN IEC 61076-2-115:2023 (E)****European foreword**

The text of document 48B/2948/CDV, future edition 1 of IEC 61076-2-115, prepared by SC 48B "Electrical connectors" of IEC/TC 48 "Electrical connectors and mechanical structures for electrical and electronic equipment" was submitted to the IEC-CENELEC parallel vote and approved by CENELEC as EN IEC 61076-2-115:2023.

The following dates are fixed:

- latest date by which the document has to be implemented at national (dop) 2024-03-27 level by publication of an identical national standard or by endorsement
- latest date by which the national standards conflicting with the (dow) 2026-06-27 document have to be withdrawn

Attention is drawn to the possibility that some of the elements of this document may be the subject of patent rights. CENELEC shall not be held responsible for identifying any or all such patent rights.

Any feedback and questions on this document should be directed to the users' national committee. A complete listing of these bodies can be found on the CENELEC website.

**Endorsement notice**

The text of the International Standard IEC 61076-2-115:2023 was approved by CENELEC as a European Standard without any modification.

## Annex ZA (normative)

### Normative references to international publications with their corresponding European publications

The following documents are referred to in the text in such a way that some or all of their content constitutes requirements of this document. For dated references, only the edition cited applies. For undated references, the latest edition of the referenced document (including any amendments) applies.

NOTE 1 Where an International Publication has been modified by common modifications, indicated by (mod), the relevant EN/HD applies.

NOTE 2 Up-to-date information on the latest versions of the European Standards listed in this annex is available here: [www.cencenelec.eu](http://www.cencenelec.eu).

<u>Publication</u>	<u>Year</u>	<u>Title</u>	<u>EN/HD</u>	<u>Year</u>
IEC 60050-581	-	International Electrotechnical Vocabulary - Part 581: Electromechanical components for electronic equipment	-	-
IEC 60068-1	-	Environmental testing - Part 1: General and guidance	EN 60068-1	-
IEC 60068-2-60	-	Environmental testing - Part 2-60: Tests - Test Ke: Flowing mixed gas corrosion test	EN 60068-2-60	-
IEC 60228	-	Conductors of insulated cables	EN 60228	-
IEC 60352-2	-	Solderless connections - Part 2: Crimped connections - General requirements, test methods and practical guidance	EN 60352-2	-
IEC 60352-3	-	Solderless connections - Part 3: Accessible insulation displacement (ID) connections - General requirements, test methods and practical guidance	EN IEC 60352-3	-
IEC 60352-4	-	Solderless connections - Part 4: Non-accessible insulation displacement (ID) connections - General requirements, test methods and practical guidance	EN IEC 60352-4	-
IEC 60352-5	-	Solderless connections - Part 5: Press-in connections - General requirements, test methods and practical guidance	EN IEC 60352-5	-
IEC 60352-6	-	Solderless connections - Part 6: Insulation piercing connections - General requirements, test methods and practical guidance	EN IEC 60352-6	-
IEC 60352-7	-	Solderless connections - Part 7: Spring clamp connections - General requirements, test methods and practical guidance	EN IEC 60352-7	-
IEC 60512-1	-	Connectors for electrical and electronic equipment - Tests and measurements - Part 1: Generic specification	EN IEC 60512-1	-

**EN IEC 61076-2-115:2023 (E)**

<u>Publication</u>	<u>Year</u>	<u>Title</u>	<u>EN/HD</u>	<u>Year</u>
IEC 60512-1-1	-	Connectors for electronic equipment - Tests and measurements - Part 1-1: General examination - Test 1a: Visual examination	EN 60512-1-1	-
IEC 60512-1-2	-	Connectors for electronic equipment - Tests and measurements - Part 1-2: General examination - Test 1b: Examination of dimension and mass	EN 60512-1-2	-
IEC 60512-2-1	-	Connectors for electronic equipment - Tests and measurements - Part 2-1: Electrical continuity and contact resistance tests - Test 2a: Contact resistance - Millivolt level method	EN 60512-2-1	-
IEC 60512-2-2	-	Connectors for electronic equipment - Tests and measurements - Part 2-2: Electrical continuity and contact resistance tests - Test 2b: Contact resistance - Specified test current method	EN 60512-2-2	-
IEC 60512-2-5	-	Connectors for electronic equipment - Tests and measurements - Part 2-5: Electrical continuity and contact resistance tests - Test 2e: Contact disturbance	EN 60512-2-5	-
IEC 60512-2-6	-	Connectors for electronic equipment - Tests and measurements - Part 2-6: Electrical continuity and contact resistance tests - Test 2f: Housing (shell) electrical continuity	EN 60512-2-6	-
IEC 60512-3-1	-	Connectors for electronic equipment - Tests and measurements - Part 3-1: Insulation tests - Test 3a: Insulation resistance	EN 60512-3-1	-
IEC 60512-4-1	-	Connectors for electronic equipment - Tests and measurements - Part 4-1: Voltage stress tests - Test 4a: Voltage proof	EN 60512-4-1	-
IEC 60512-5-2	-	Connectors for electronic equipment - Tests and measurements - Part 5-2: Current-carrying capacity tests - Test 5b: Current-temperature derating	EN 60512-5-2	-
IEC 60512-6-3	-	Connectors for electronic equipment - Tests and measurements - Part 6-3: Dynamic stress tests - Test 6c: Shock	EN 60512-6-3	-
IEC 60512-6-4	-	Connectors for electronic equipment - Tests and measurements - Part 6-4: Dynamic stress tests - Test 6d: Vibration (sinusoidal)	EN 60512-6-4	-
IEC 60512-7-1	-	Connectors for electronic equipment - Tests and measurements - Part 7-1: Impact tests (free connectors) - Test 7a: Free fall (repeated)	EN 60512-7-1	-
IEC 60512-9-1	-	Connectors for electronic equipment - Tests and measurements - Part 9-1: Endurance tests - Test 9a: Mechanical operation	EN 60512-9-1	-
IEC 60512-9-2	-	Connectors for electronic equipment - Tests and measurements - Part 9-2: Endurance tests - Test 9b: Electrical load and temperature	EN 60512-9-2	-

**EN IEC 61076-2-115:2023 (E)**

<u>Publication</u>	<u>Year</u>	<u>Title</u>	<u>EN/HD</u>	<u>Year</u>
IEC 60512-11-1	-	Connectors for electrical and electronic equipment - Tests and measurements - Part 11-1: Climatic tests - Test 11a - Climatic sequence	EN IEC 60512-11-1	-
IEC 60512-11-3	-	Connectors for electronic equipment - Tests and measurements - Part 11-3: Climatic tests - Test 11c: Damp heat, steady state	EN 60512-11-3	-
IEC 60512-11-4	-	Connectors for electronic equipment - Tests and measurements - Part 11-4: Climatic tests - Test 11d: Rapid change of temperature	EN 60512-11-4	-
IEC 60512-11-6	-	Connectors for electronic equipment - Tests and measurements - Part 11-6: Climatic tests - Test 11f: Corrosion, salt mist	EN 60512-11-6	-
IEC 60512-11-7	-	Connectors for electronic equipment - Tests and measurements - Part 11-7: Climatic tests - Test 11g: Flowing mixed gas corrosion test	EN 60512-11-7	-
IEC 60512-11-9	-	Connectors for electronic equipment - Tests and measurements - Part 11-9: Climatic tests - Test 11i: Dry heat	EN 60512-11-9	-
IEC 60512-11-10	-	Connectors for electronic equipment - Tests and measurements - Part 11-10: Climatic tests - Test 11j: Cold	EN 60512-11-10	-
IEC 60512-11-11	-	Connectors for electronic equipment - Tests and measurements - Part 11-11: Climatic tests - Test 11k: Low air pressure	EN 60512-11-11	-
IEC 60512-11-12	-	Connectors for electronic equipment - Tests and measurements - Part 11-12: Climatic tests - Test 11m: Damp heat, cyclic	EN 60512-11-12	-
IEC 60512-13-1	-	Connectors for electronic equipment - Tests and measurements - Part 13-1: Mechanical operation tests - Test 13a: Engaging and separating forces	EN 60512-13-1	-
IEC 60512-13-5	-	Connectors for electronic equipment - Tests and measurements - Part 13-5: Mechanical operation tests - Test 13e: Polarizing and keying method	EN 60512-13-5	-
IEC 60512-15-1	-	Connectors for electronic equipment - Tests and measurements - Part 15-1: Connector tests (mechanical) - Test 15a: Contact retention in insert	EN 60512-15-1	-
IEC 60512-15-6	-	Connectors for electronic equipment - Tests and measurements - Part 15-6: Connector tests (mechanical) - Test 15f: Effectiveness of connector coupling devices	EN 60512-15-6	-
IEC 60512-16-5	-	Connectors for electronic equipment - Tests and measurements - Part 16-5: Mechanical tests on contacts and terminations - Test 16e: Gauge retention force (resilient contacts)	EN 60512-16-5	-
IEC 60512-20-3	-	Connectors for electronic equipment - Tests and measurements - Part 20-3: Fire hazard tests - Test 20c: Flammability, glow-wire	EN 60512-20-3	-

**EN IEC 61076-2-115:2023 (E)**

<u>Publication</u>	<u>Year</u>	<u>Title</u>	<u>EN/HD</u>	<u>Year</u>
IEC 60529	1989	Degrees of protection provided by enclosures (IP Code)	EN 60529	1991
-	-		+ corrigendum May	1993
+ A1	1999		+ A1	2000
+ A2	2013		+ A2	2013
IEC 60664-1	2020	Insulation coordination for equipment within low-voltage supply systems - Part 1: Principles, requirements and tests	EN IEC 60664-1	2020
IEC 60695-2-11	2021	Fire hazard testing - Part 2-11: Glowing/hot-wire based test methods - Glow-wire flammability test method for end products (GWEPT)	EN IEC 60695-2-11	2021
IEC 60999-1	-	Connecting devices - Electrical copper conductors - Safety requirements for screw-type and screwless-type clamping units - Part 1: General requirements and particular requirements for clamping units for conductors from 0,2 mm <sup>2</sup> up to 35 mm <sup>2</sup> (included)	EN 60999-1	-
IEC 61076-1	2006	Connectors for electronic equipment - Product requirements - Part 1: Generic specification	EN 61076-1	2006
+ A1	2019		+ A1	2019
IEC 61076-2	-	Connectors for electronic equipment - Product requirements - Part 2: Sectional specification for circular connectors	EN 61076-2	-
IEC 61984	2008	Connectors - Safety requirements and tests	EN 61984	2009
IEC 62430	2019	Environmentally conscious design (ECD) - Principles, requirements and guidance	EN IEC 62430	2019
IEC Guide 109	-	Environmental aspects - Inclusion in electrotechnical product standards	-	-
ISO 6508-1	-	Metallic materials - Rockwell hardness test - Part 1: Test method	EN ISO 6508-1	-
ISO 11469	-	Plastics - Generic identification and marking of plastics products	EN ISO 11469	-
ISO 21920-1	2021	Geometrical product specifications (GPS) - Surface texture: Profile - Part 1: Indication of surface texture	EN ISO 21920-1	2022







# IEC 61076-2-115

Edition 1.0 2023-05

# INTERNATIONAL STANDARD

# NORME INTERNATIONALE

**Connectors for electrical and electronic equipment – Product requirements – Part 2-115: Circular connectors – Detail specification for 12-pole shielded connectors with 2 A rated current and IP65/IP67 metal housing with push-pull locking**

**Connecteurs pour équipements électriques et électroniques – Exigences de produit – Partie 2-115: Connecteurs circulaires – Spécification particulière relative aux connecteurs blindés à 12 pôles avec un courant assigné de 2 A et un boîtier métallique IP65/IP67 équipé d'un mécanisme de verrouillage de type pousser-tirer**



**THIS PUBLICATION IS COPYRIGHT PROTECTED**  
**Copyright © 2023 IEC, Geneva, Switzerland**

All rights reserved. Unless otherwise specified, no part of this publication may be reproduced or utilized in any form or by any means, electronic or mechanical, including photocopying and microfilm, without permission in writing from either IEC or IEC's member National Committee in the country of the requester. If you have any questions about IEC copyright or have an enquiry about obtaining additional rights to this publication, please contact the address below or your local IEC member National Committee for further information.

Droits de reproduction réservés. Sauf indication contraire, aucune partie de cette publication ne peut être reproduite ni utilisée sous quelque forme que ce soit et par aucun procédé, électronique ou mécanique, y compris la photocopie et les microfilms, sans l'accord écrit de l'IEC ou du Comité national de l'IEC du pays du demandeur. Si vous avez des questions sur le copyright de l'IEC ou si vous désirez obtenir des droits supplémentaires sur cette publication, utilisez les coordonnées ci-après ou contactez le Comité national de l'IEC de votre pays de résidence.

IEC Secretariat  
3, rue de Varembe  
CH-1211 Geneva 20  
Switzerland

Tel.: +41 22 919 02 11  
[info@iec.ch](mailto:info@iec.ch)  
[www.iec.ch](http://www.iec.ch)

#### About the IEC

The International Electrotechnical Commission (IEC) is the leading global organization that prepares and publishes International Standards for all electrical, electronic and related technologies.

#### About IEC publications

The technical content of IEC publications is kept under constant review by the IEC. Please make sure that you have the latest edition, a corrigendum or an amendment might have been published.

#### IEC publications search - [webstore.iec.ch/advsearchform](http://webstore.iec.ch/advsearchform)

The advanced search enables to find IEC publications by a variety of criteria (reference number, text, technical committee, ...). It also gives information on projects, replaced and withdrawn publications.

#### IEC Just Published - [webstore.iec.ch/justpublished](http://webstore.iec.ch/justpublished)

Stay up to date on all new IEC publications. Just Published details all new publications released. Available online and once a month by email.

#### IEC Customer Service Centre - [webstore.iec.ch/csc](http://webstore.iec.ch/csc)

If you wish to give us your feedback on this publication or need further assistance, please contact the Customer Service Centre: [sales@iec.ch](mailto:sales@iec.ch).

#### IEC Products & Services Portal - [products.iec.ch](http://products.iec.ch)

Discover our powerful search engine and read freely all the publications previews. With a subscription you will always have access to up to date content tailored to your needs.

#### Electropedia - [www.electropedia.org](http://www.electropedia.org)

The world's leading online dictionary on electrotechnology, containing more than 22 300 terminological entries in English and French, with equivalent terms in 19 additional languages. Also known as the International Electrotechnical Vocabulary (IEV) online.

---

#### A propos de l'IEC

La Commission Electrotechnique Internationale (IEC) est la première organisation mondiale qui élabore et publie des Normes internationales pour tout ce qui a trait à l'électricité, à l'électronique et aux technologies apparentées.

#### A propos des publications IEC

Le contenu technique des publications IEC est constamment revu. Veuillez vous assurer que vous possédez l'édition la plus récente, un corrigendum ou amendement peut avoir été publié.

#### Recherche de publications IEC -

#### [webstore.iec.ch/advsearchform](http://webstore.iec.ch/advsearchform)

La recherche avancée permet de trouver des publications IEC en utilisant différents critères (numéro de référence, texte, comité d'études, ...). Elle donne aussi des informations sur les projets et les publications remplacées ou retirées.

#### IEC Just Published - [webstore.iec.ch/justpublished](http://webstore.iec.ch/justpublished)

Restez informé sur les nouvelles publications IEC. Just Published détaille les nouvelles publications parues. Disponible en ligne et une fois par mois par email.

#### Service Clients - [webstore.iec.ch/csc](http://webstore.iec.ch/csc)

Si vous désirez nous donner des commentaires sur cette publication ou si vous avez des questions contactez-nous: [sales@iec.ch](mailto:sales@iec.ch).

#### IEC Products & Services Portal - [products.iec.ch](http://products.iec.ch)

Découvrez notre puissant moteur de recherche et consultez gratuitement tous les aperçus des publications. Avec un abonnement, vous aurez toujours accès à un contenu à jour adapté à vos besoins.

#### Electropedia - [www.electropedia.org](http://www.electropedia.org)

Le premier dictionnaire d'électrotechnologie en ligne au monde, avec plus de 22 300 articles terminologiques en anglais et en français, ainsi que les termes équivalents dans 19 langues additionnelles. Egalement appelé Vocabulaire Electrotechnique International (IEV) en ligne.



IEC 61076-2-115

Edition 1.0 2023-05

# INTERNATIONAL STANDARD

# NORME INTERNATIONALE

**Connectors for electrical and electronic equipment – Product requirements – Part 2-115: Circular connectors – Detail specification for 12-pole shielded connectors with 2 A rated current and IP65/IP67 metal housing with push-pull locking**

**Connecteurs pour équipements électriques et électroniques – Exigences de produit – Partie 2-115: Connecteurs circulaires – Spécification particulière relative aux connecteurs blindés à 12 pôles avec un courant assigné de 2 A et un boîtier métallique IP65/IP67 équipé d'un mécanisme de verrouillage de type pousser-tirer**

INTERNATIONAL  
ELECTROTECHNICAL  
COMMISSION

COMMISSION  
ELECTROTECHNIQUE  
INTERNATIONALE

ICS 31.220.10

ISBN 978-2-8322-7022-6

**Warning! Make sure that you obtained this publication from an authorized distributor.  
Attention! Veuillez vous assurer que vous avez obtenu cette publication via un distributeur agréé.**

## CONTENTS

FOREWORD.....	5
1 Scope.....	8
2 Normative references .....	8
3 Terms and definitions .....	11
4 Technical information .....	11
4.1 Recommended method of termination .....	11
4.1.1 General .....	11
4.1.2 Number of contacts and contact cavities.....	11
4.2 Ratings and characteristics .....	11
4.3 Systems of levels.....	12
4.3.1 Performance levels .....	12
4.3.2 Compatibility levels.....	12
4.4 Classification into climatic categories.....	12
4.5 Creepage and clearance distances .....	12
4.6 Current-carrying capacity .....	12
4.7 Marking.....	12
5 Dimensional information .....	12
5.1 General.....	12
5.2 Isometric view and common features .....	12
5.2.1 Isometric view of free connector .....	12
5.2.2 Isometric view of fixed connector .....	13
5.3 Free connector.....	14
5.3.1 Dimensions.....	14
5.3.2 Terminations.....	15
5.4 Fixed connector .....	15
5.4.1 Dimensions.....	15
5.4.2 Terminations.....	16
5.5 Mounting information for connectors .....	16
5.6 Gauges – Sizing gauges and retention force gauges.....	16
6 Technical characteristics .....	16
6.1 Classification into climatic categories.....	16
6.2 Electrical characteristics .....	16
6.2.1 Creepage and clearance distances .....	16
6.2.2 Voltage proof.....	17
6.2.3 Current-carrying capacity.....	17
6.2.4 Electrical load and temperature .....	17
6.2.5 Contact resistance .....	18
6.2.6 Housing electrical continuity .....	18
6.2.7 Insulation resistance.....	18
6.3 Mechanical characteristics .....	18
6.3.1 Mechanical operation.....	18
6.3.2 Effectiveness of connector coupling devices .....	18
6.3.3 Gauge retention force (resilient contact) .....	19
6.3.4 Engaging and separating forces.....	19
6.3.5 Contact retention in insert.....	19
6.3.6 Polarizing and keying method.....	19

6.4	Dynamic stress tests .....	19
6.4.1	Vibration (sine) .....	19
6.4.2	Shock .....	20
6.4.3	Free fall (repeated) .....	20
6.4.4	IP degree of protection .....	20
6.4.5	Glow-wire flammability test method for end-products (GWEPT) .....	20
6.5	Climatic tests .....	20
6.5.1	Rapid change of temperature .....	20
6.5.2	Dry heat .....	20
6.5.3	Low temperature .....	21
6.5.4	Low air pressure .....	21
6.5.5	Damp heat, cyclic .....	21
6.5.6	Damp heat, steady state .....	21
6.5.7	Corrosion, salt mist .....	21
6.5.8	Flowing mixed gas corrosion .....	21
6.6	Environmental aspects .....	21
6.6.1	Marking of insulation material (plastic) .....	21
6.6.2	Design/use of material .....	22
7	Test schedule .....	22
7.1	General .....	22
7.2	Test schedules .....	22
7.2.1	Basic (minimum) test schedule .....	22
7.2.2	Full test schedule .....	22
7.3	Test procedures and measurement methods .....	32
7.4	Pre-conditioning .....	33
7.5	Wiring and mounting of test specimens .....	33
7.5.1	Wiring .....	33
7.5.2	Mounting .....	33
Figure 1 – Free connector .....		13
Figure 2 – Fixed connector .....		13
Figure 3 – Free connector .....		14
Figure 4 – Fixed connector .....		15
Figure 5 – Gauge for contact .....		16
Figure 6 – Current-temperature derating (0,20 mm <sup>2</sup> wire size) .....		17
Table 1 – Free connector dimensions .....		14
Table 2 – Fixed connector dimensions .....		15
Table 3 – Gauge dimensions .....		16
Table 4 – Climatic category .....		16
Table 5 – Voltage proof .....		17
Table 6 – Number of test specimens .....		22
Table 7 – Test group P .....		23
Table 8 – Test group AP .....		24
Table 9 – Test group BP .....		27
Table 10 – Test group CP .....		29

Table 11 – Test group DP .....	30
Table 12 – Test group EP .....	32
Table 13 – Test group GP .....	32

## INTERNATIONAL ELECTROTECHNICAL COMMISSION

**CONNECTORS FOR ELECTRICAL AND ELECTRONIC EQUIPMENT –  
PRODUCT REQUIREMENTS –****Part 2-115: Circular connectors – Detail specification for 12-pole  
shielded connectors with 2 A rated current and IP65/IP67  
metal housing with push-pull locking**

## FOREWORD

- 1) The International Electrotechnical Commission (IEC) is a worldwide organization for standardization comprising all national electrotechnical committees (IEC National Committees). The object of IEC is to promote international co-operation on all questions concerning standardization in the electrical and electronic fields. To this end and in addition to other activities, IEC publishes International Standards, Technical Specifications, Technical Reports, Publicly Available Specifications (PAS) and Guides (hereafter referred to as "IEC Publication(s)"). Their preparation is entrusted to technical committees; any IEC National Committee interested in the subject dealt with may participate in this preparatory work. International, governmental and non-governmental organizations liaising with the IEC also participate in this preparation. IEC collaborates closely with the International Organization for Standardization (ISO) in accordance with conditions determined by agreement between the two organizations.
- 2) The formal decisions or agreements of IEC on technical matters express, as nearly as possible, an international consensus of opinion on the relevant subjects since each technical committee has representation from all interested IEC National Committees.
- 3) IEC Publications have the form of recommendations for international use and are accepted by IEC National Committees in that sense. While all reasonable efforts are made to ensure that the technical content of IEC Publications is accurate, IEC cannot be held responsible for the way in which they are used or for any misinterpretation by any end user.
- 4) In order to promote international uniformity, IEC National Committees undertake to apply IEC Publications transparently to the maximum extent possible in their national and regional publications. Any divergence between any IEC Publication and the corresponding national or regional publication shall be clearly indicated in the latter.
- 5) IEC itself does not provide any attestation of conformity. Independent certification bodies provide conformity assessment services and, in some areas, access to IEC marks of conformity. IEC is not responsible for any services carried out by independent certification bodies.
- 6) All users should ensure that they have the latest edition of this publication.
- 7) No liability shall attach to IEC or its directors, employees, servants or agents including individual experts and members of its technical committees and IEC National Committees for any personal injury, property damage or other damage of any nature whatsoever, whether direct or indirect, or for costs (including legal fees) and expenses arising out of the publication, use of, or reliance upon, this IEC Publication or any other IEC Publications.
- 8) Attention is drawn to the Normative references cited in this publication. Use of the referenced publications is indispensable for the correct application of this publication.
- 9) Attention is drawn to the possibility that some of the elements of this IEC Publication may be the subject of patent rights. IEC shall not be held responsible for identifying any or all such patent rights.

IEC 61076-2-115 has been prepared by subcommittee 48B: Electrical connectors, of IEC technical committee 48: Electrical connectors and mechanical structures for electrical and electronic equipment. It is an International Standard.

The text of this International Standard is based on the following documents:

Draft	Report on voting
48B/2948/CDV	48B/2989/RVC

Full information on the voting for its approval can be found in the report on voting indicated in the above table.

The language used for the development of this International Standard is English.

This document was drafted in accordance with ISO/IEC Directives, Part 2, and developed in accordance with ISO/IEC Directives, Part 1 and ISO/IEC Directives, IEC Supplement, available at [www.iec.ch/members\\_experts/refdocs](http://www.iec.ch/members_experts/refdocs). The main document types developed by IEC are described in greater detail at [www.iec.ch/publications](http://www.iec.ch/publications).

A list of all parts of IEC 61076 series, under the general title *Connectors for electrical and electronic equipment – Product requirements*, can be found on the IEC website.

Future standards in this series will carry the new general title as cited above. Titles of existing standards in this series will be updated at the time of the next edition.

The committee has decided that the contents of this document will remain unchanged until the stability date indicated on the IEC website under [webstore.iec.ch](http://webstore.iec.ch) in the data related to the specific document. At this date, the document will be

- reconfirmed,
- withdrawn,
- replaced by a revised edition, or
- amended.

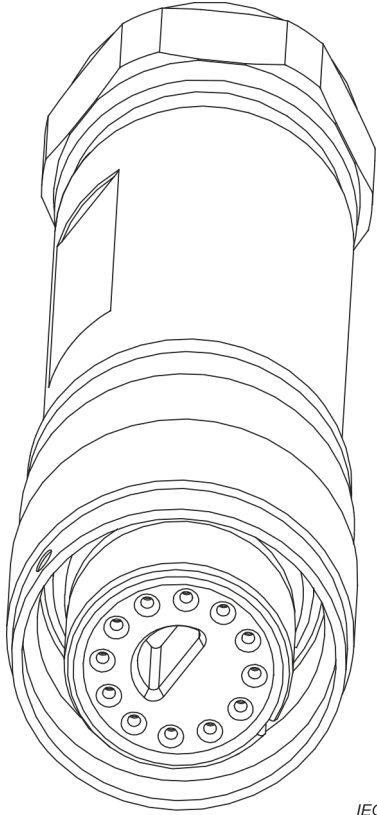
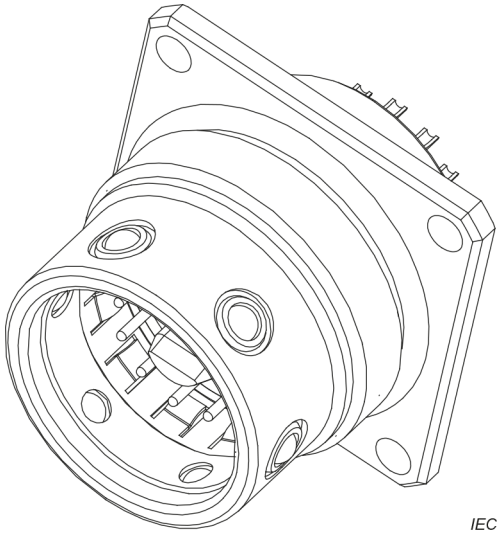

The International Electrotechnical Commission IEC SC 48B—Electrical connectors		IEC 61076-2-115 Ed.1
Detail specification in accordance with IEC 61076-2		
Free connector	 <p style="text-align: right;">IEC</p>	<p>For rated current of 2 A; 12-pole; Female contacts; Push-pull locking; 360° shielding.</p>
Fixed connector	 <p style="text-align: right;">IEC</p>	<p>For rated current of 2 A; 12-pole; Male contacts; Push-pull locking; 360° shielding.</p>

# CONNECTORS FOR ELECTRICAL AND ELECTRONIC EQUIPMENT – PRODUCT REQUIREMENTS –

## Part 2-115: Circular connectors – Detail specification for 12-pole shielded connectors with 2 A rated current and IP65/IP67 metal housing with push-pull locking

### 1 Scope

This part of IEC 61076-2 describes free and fixed 12P shielded circular connectors with 2 A rated current, rated voltage up to and including 50 V AC/DC, IP65/IP67 metal housing with push-pull locking (hereinafter referred to as a connectors) for use in electrical and electronic equipment. It includes overall dimensions, interface dimensions, technical characteristics, performance requirements and test methods.

### 2 Normative references

The following documents are referred to in the text in such a way that some or all of their content constitutes requirements of this document. For dated references, only the edition cited applies. For undated references, the latest edition of the referenced document (including any amendments) applies.

IEC 60050-581, *International Electrotechnical Vocabulary (IEV) – Part 581: Electromechanical components for electronic equipment*

IEC 60068-1, *Environmental testing – Part 1: General and guidance*

IEC 60068-2-60, *Environmental testing – Part 2-60: Tests – Test Ke: Flowing mixed gas corrosion test*

IEC 60228, *Conductors of insulated cables*

IEC 60352-2, *Solderless connections – Part 2: Crimped connections – General requirements, test methods and practical guidance*

IEC 60352-3, *Solderless connections – Part 3: Accessible insulation displacement (ID) connections – General requirements, test methods and practical guidance*

IEC 60352-4, *Solderless connections – Part 4: Non-accessible insulation displacement (ID) connections – General requirements, test methods and practical guidance*

IEC 60352-5, *Solderless connections – Part 5: Press-in connections – General requirements, test methods and practical guidance*

IEC 60352-6, *Solderless connections – Part 6: Insulation piercing connections – General requirements, test methods and practical guidance*

IEC 60352-7, *Solderless connections – Part 7: Spring clamp connections – General requirements, test methods and practical guidance*

IEC 60512-1, *Connectors for electrical and electronic equipment – Tests and measurements – Part 1: Generic specification*

IEC 60512-1-1, *Connectors for electronic equipment – Tests and measurements – Part 1-1: General examination-Test 1a: Visual examination*

IEC 60512-1-2, *Connectors for electronic equipment – Tests and measurements – Part 1-2: General examination-Test 1b: Examination of dimension and mass*

IEC 60512-2-1, *Connectors for electronic equipment – Tests and measurements – Part 2-1: Electrical continuity and contact resistance tests – Test 2a: Contact resistance – Millivolt level method*

IEC 60512-2-2, *Connectors for electronic equipment – Tests and measurements – Part 2-2: Electrical continuity and contact resistance tests – Test 2b: Contact resistance – Specified test current method*

IEC 60512-2-5, *Connectors for electronic equipment – Tests and measurements – Part 2-5: Electrical continuity and contact resistance tests – Test 2e: Contact disturbance*

IEC 60512-2-6, *Connectors for electronic equipment – Tests and measurements – Part 2-6: Electrical continuity and contact resistance tests – Test 2f: Housing (shell) electrical continuity*

IEC 60512-3-1, *Connectors for electronic equipment – Tests and measurements – Part 3-1: Insulation tests – Test 3a: Insulation resistance*

IEC 60512-4-1, *Connectors for electronic equipment – Tests and measurements – Part 4-1: Voltage stress tests – Test 4a: Voltage proof*

IEC 60512-5-2, *Connectors for electronic equipment – Tests and measurements – Part 5-2: Current-carrying capacity tests – Test 5b: Current-temperature derating*

IEC 60512-6-3, *Connectors for electronic equipment – Tests and measurements – Part 6-3: Dynamic stress tests – Test 6c: Shock*

IEC 60512-6-4, *Connectors for electronic equipment – Tests and measurements – Part 6-4: Dynamic stress tests – Test 6d: Vibration (sinusoidal)*

IEC 60512-7-1, *Connectors for electronic equipment – Tests and measurements – Part 7-1: Impact tests (free connectors) – Test 7a: Free fall (repeated)*

IEC 60512-9-1, *Connectors for electronic equipment – Tests and measurements – Part 9-1: Endurance tests – Test 9a: Mechanical operation*

IEC 60512-9-2, *Connectors for electronic equipment – Tests and measurements – Part 9-2: Endurance tests – Test 9b: Electrical load and temperature*

IEC 60512-11-1, *Connectors for electrical and electronic equipment – Tests and measurements – Part 11-1: Climatic tests – Test 11a – Climatic sequence*

IEC 60512-11-3, *Connectors for electronic equipment – Tests and measurements – Part 11-3: Climatic tests – Test 11c: Damp heat, steady state*

IEC 60512-11-4, *Connectors for electronic equipment – Tests and measurements – Part 11-4: Climatic tests – Test 11d: Rapid change of temperature*

IEC 60512-11-6, *Connectors for electronic equipment – Tests and measurements – Part 11-6: Climatic tests – Test 11f: Corrosion, salt mist*

IEC 60512-11-7, *Connectors for electronic equipment – Tests and measurements – Part 11-7: Climatic tests – Test 11g: Flowing mixed gas corrosion test*

IEC 60512-11-9, *Connectors for electronic equipment – Tests and measurements – Part 11-9: Climatic tests – Test 11i: Dry heat*

IEC 60512-11-10, *Connectors for electronic equipment – Tests and measurements – Part 11-10: Climatic tests – Test 11j: Cold*

IEC 60512-11-11, *Connectors for electronic equipment – Tests and measurements – Part 11-11: Climatic tests – Test 11k: Low air pressure*

IEC 60512-11-12, *Connectors for electronic equipment – Tests and measurements – Part 11-12: Climatic tests – Test 11m: Damp heat, cyclic*

IEC 60512-13-1, *Connectors for electronic equipment – Tests and measurements – Part 13-1: Mechanical operation tests – Test 13a: Engaging and separating forces*

IEC 60512-13-5, *Connectors for electronic equipment – Tests and measurements – Part 13-5: Mechanical operation tests – Test 13e: Polarizing and keying method*

IEC 60512-15-1, *Connectors for electronic equipment – Tests and measurements – Part 15-1: Connector tests (mechanical) – Test 15a: Contact retention in insert*

IEC 60512-15-6, *Connectors for electronic equipment – Tests and measurements – Part 15-6: Connector tests (mechanical) – Test 15f: Effectiveness of connector coupling devices*

IEC 60512-16-5, *Connectors for electronic equipment – Tests and measurements – Part 16-5: Mechanical tests on contacts and terminations – Test 16e: Gauge retention force (resilient contacts)*

IEC 60512-20-3, *Connectors for electronic equipment – Tests and measurements – Part 20-3: Fire hazard tests - Test 20c: Flammability, glow-wire*

IEC 60529:1989, *Degrees of protection provided by enclosures (IP Code)*

IEC 60529:1989/AMD1:1999

IEC 60529:1989/AMD2:2013

IEC 60664-1:2020, *Insulation coordination for equipment within low-voltage supply systems – Part 1: Principles, requirements and tests*

IEC 60695-2-11:2021, *Fire hazard testing – Part 2-11: Glowing/hot-wire based test methods – Glow-wire flammability test method for end products (GWEPT)*

IEC 60999-1, *Connecting devices – Electrical copper conductors – Safety requirements for screw-type and screwless-type clamping units – Part 1: General requirements and particular requirements for clamping units for conductors from 0,2 mm<sup>2</sup> up to 35 mm<sup>2</sup> (included)*

IEC 61076-1:2006, *Connectors for electronic equipment – Product requirements – Part 1: Generic specification*

IEC 61076-1:2006/AMD1:2019

IEC 61076-2, *Connectors for electronic equipment – Product requirements – Part 2: Sectional specification for circular connectors*

IEC 61984:2008, *Connectors – Safety requirements and tests*

IEC 61076-2-115:2023 © IEC 2023

– 11 –

IEC 62430:2019, *Environmentally conscious design (ECD) – Principles, requirements and guidance*

IEC Guide 109, *Environmental aspects – Inclusion in electrotechnical product standards*

ISO 6508-1, *Metallic materials – Rockwell hardness test – Part 1: Test method*

ISO 11469, *Plastics – Generic identification and marking of plastics products*

ISO 21920-1:2021, *Geometrical product specifications (GPS) – Surface texture: Profile – Part 1: Indication of surface texture*

**koniec náhľadu – text ďalej pokračuje v platenej verzii STN**