

<b>STN</b>	<b>Čistiarne odpadových vôd Časť 6: Aktivačné procesy</b>	<b>STN EN 12255-6</b>  75 6410
------------	---	--

Wastewater treatment plants - Part 6: Activated sludge process

Táto norma obsahuje anglickú verziu európskej normy.  
This standard includes the English version of the European Standard.

Táto norma bola oznámená vo Vestníku ÚNMS SR č. 09/23

Obsahuje: EN 12255-6:2023

Oznámením tejto normy sa ruší  
STN EN 12255-6 (75 6410) zo septembra 2003

**137373**

---

Úrad pre normalizáciu, metrológiu a skúšobníctvo Slovenskej republiky, 2023  
Slovenská technická norma a technická normalizačná informácia je chránená zákonom č. 60/2018 Z. z. o technickej normalizácii  
v znení neskorších predpisov.

EUROPEAN STANDARD

EN 12255-6

NORME EUROPÉENNE

EUROPÄISCHE NORM

July 2023

ICS 13.060.30

Supersedes EN 12255-6:2002

English Version

## Wastewater treatment plants - Part 6: Activated sludge process

Stations d'épuration - Partie 6: Procédé à boues  
activées

Kläranlagen - Teil 6: Belebungsverfahren

This European Standard was approved by CEN on 28 May 2023.

CEN members are bound to comply with the CEN/CENELEC Internal Regulations which stipulate the conditions for giving this European Standard the status of a national standard without any alteration. Up-to-date lists and bibliographical references concerning such national standards may be obtained on application to the CEN-CENELEC Management Centre or to any CEN member.

This European Standard exists in three official versions (English, French, German). A version in any other language made by translation under the responsibility of a CEN member into its own language and notified to the CEN-CENELEC Management Centre has the same status as the official versions.

CEN members are the national standards bodies of Austria, Belgium, Bulgaria, Croatia, Cyprus, Czech Republic, Denmark, Estonia, Finland, France, Germany, Greece, Hungary, Iceland, Ireland, Italy, Latvia, Lithuania, Luxembourg, Malta, Netherlands, Norway, Poland, Portugal, Republic of North Macedonia, Romania, Serbia, Slovakia, Slovenia, Spain, Sweden, Switzerland, Türkiye and United Kingdom.



EUROPEAN COMMITTEE FOR STANDARDIZATION  
COMITÉ EUROPÉEN DE NORMALISATION  
EUROPÄISCHES KOMITEE FÜR NORMUNG

**CEN-CENELEC Management Centre: Rue de la Science 23, B-1040 Brussels**

## EN 12255-6:2023 (E)

<b>Contents</b>		<b>Page</b>
European foreword .....		4
Introduction .....		6
1	Scope.....	7
2	Normative references.....	7
3	Terms and definitions.....	7
4	Symbols and abbreviations .....	8
4.1	Symbols .....	8
4.2	Indices (not included in the symbols or abbreviations below).....	10
4.3	Abbreviations.....	11
5	Requirements.....	12
5.1	General.....	12
5.2	Planning .....	13
5.2.1	Basic information.....	13
5.2.2	System selection.....	14
5.2.3	Biological reactors.....	18
5.2.4	Clarifiers.....	18
5.2.5	Environmental impact .....	19
5.3	Detailed Design.....	19
5.3.1	Flow-splitting .....	19
5.3.2	Biological reactors.....	19
5.3.3	Mixing.....	20
5.3.4	Aeration.....	22
5.3.5	Secondary clarifiers .....	26
5.3.6	Return and surplus sludge systems .....	28
5.3.7	Internal recirculation.....	28
5.3.8	Control and automation .....	28
6	Test methods .....	30
Annex A (informative) Design of biological reactors .....		31
Annex B (informative) Raw wastewater characteristics .....		32
Annex C (informative) Removal efficiency of primary clarifiers.....		33
Annex D (informative) External carbon sources .....		34
Annex E (informative) Sludge age (MSRT) and aerobic sludge age (MASRT) .....		35
Annex F (informative) Surplus sludge production .....		37
Annex G (informative) Denitrification capacity.....		39
Annex H (informative) Oxygen Consumption .....		40
Annex I (informative) Iterative calculation of the volumetric ratio of denitrification reactors ( $V_{Den}/V_R$ ) .....		42
Annex J (informative) Reactor volume ( $V_R$ ).....		43
Annex K (informative) Internal recirculation ratio (IRR).....		44

<b>Annex L (informative) Alkalinity .....</b>	<b>45</b>
<b>Annex M (informative) Aerobic selectors .....</b>	<b>47</b>
<b>Annex N (informative) Design based on F/M-ratio .....</b>	<b>48</b>
<b>Annex O (informative) Sludge volume index (SVI) .....</b>	<b>49</b>
<b>Annex P (informative) Solids concentration of the return sludge (<math>C_{TSS,RS}</math>) .....</b>	<b>50</b>
<b>Annex Q (informative) Return sludge flow (<math>Q_{RS}</math>) and total suspended solids concentration in the biological reactor (<math>C_{TSS,R}</math>) .....</b>	<b>51</b>
<b>Annex R (informative) Surface area (<math>A_{Cla}</math>) of final clarifiers .....</b>	<b>53</b>
<b>Annex S (informative) Depth (<math>h_{Cla}</math>) of final clarifiers .....</b>	<b>54</b>
<b>Annex T (informative) Scraper Design.....</b>	<b>55</b>
<b>Annex U (informative) Return sludge balance.....</b>	<b>57</b>
<b>Annex V (informative) Influent structures.....</b>	<b>58</b>
<b>Annex W (informative) Design of a fine bubble aeration system.....</b>	<b>59</b>
<b>Bibliography .....</b>	<b>62</b>

**EN 12255-6:2023 (E)****European foreword**

This document (EN 12255-6:2023) has been prepared by Technical Committee CEN/TC 165 “Waste water Engineering”, the secretariat of which is held by DIN.

This European Standard shall be given the status of a national standard, either by publication of an identical text or by endorsement, at the latest by January 2024, and conflicting national standards shall be withdrawn at the latest by January 2024.

Attention is drawn to the possibility that some of the elements of this document may be the subject of patent rights. CEN shall not be held responsible for identifying any or all such patent rights.

This document supersedes EN 12255-6:2002.

This is the sixth part prepared by Working Group CEN/TC 165/WG 40, relating to the general requirements and processes for treatment plants for a total number of inhabitants and population equivalents (PT) over 50.

The EN 12255 series with the generic title “Wastewater treatment plants” consists of the following Parts:

- *Part 1: General construction principles*
- *Part 2: Storm management systems*
- *Part 3: Preliminary treatment*
- *Part 4: Primary treatment*
- *Part 5: Lagooning processes*
- *Part 6: Activated sludge process*
- *Part 7: Biological fixed-film reactors*
- *Part 8: Sludge treatment and storage*
- *Part 9: Odour control and ventilation*
- *Part 10: Safety principles*
- *Part 11: General data required*
- *Part 12: Control and automation*
- *Part 13: Chemical treatment — Treatment of wastewater by precipitation/flocculation*
- *Part 14: Disinfection*
- *Part 15: Measurement of the oxygen transfer in clean water in aeration tanks of activated sludge plants*
- *Part 16: Physical (mechanical) filtration*

NOTE Part 2 is under preparation.

**NOTE** For requirements on pumping installations at wastewater treatment plants see EN 752, *Drain and sewer systems outside buildings — Sewer system management* and EN 16932 (all parts), *Drain and sewer systems outside buildings — Pumping systems*.

Any feedback and questions on this document should be directed to the users' national standards body. A complete listing of these bodies can be found on the CEN website.

According to the CEN-CENELEC Internal Regulations, the national standards organisations of the following countries are bound to implement this European Standard: Austria, Belgium, Bulgaria, Croatia, Cyprus, Czech Republic, Denmark, Estonia, Finland, France, Germany, Greece, Hungary, Iceland, Ireland, Italy, Latvia, Lithuania, Luxembourg, Malta, Netherlands, Norway, Poland, Portugal, Republic of North Macedonia, Romania, Serbia, Slovakia, Slovenia, Spain, Sweden, Switzerland, Türkiye and the United Kingdom

**EN 12255-6:2023 (E)****Introduction**

Differences in wastewater treatment throughout Europe have led to a variety of systems being developed. This document gives fundamental information about the systems; this document has not attempted to specify all available systems. A generic arrangement of wastewater treatment plants is illustrated in Figure 1:

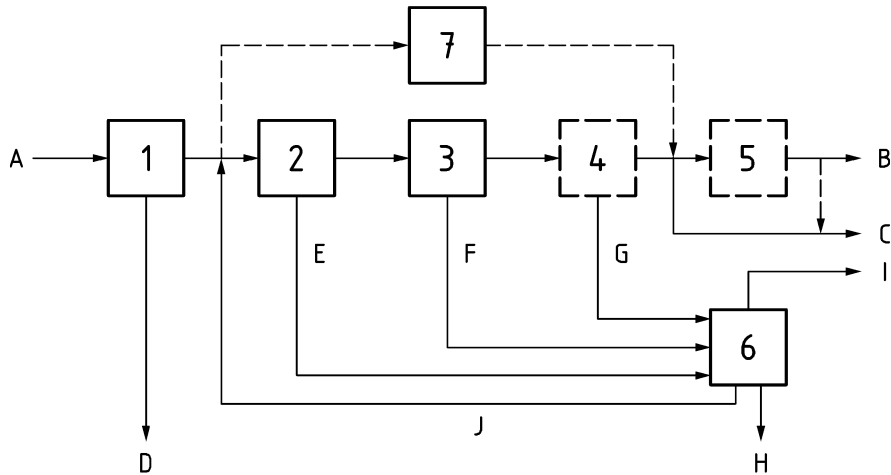
**Key:**

- 1 preliminary treatment
- 2 primary treatment
- 3 secondary treatment
- 4 tertiary treatment
- 5 additional treatment (e.g. disinfection or removal of micropollutants)
- 6 sludge treatment
- 7 lagoons (as an alternative)
- A raw wastewater
- B effluent for re-use (e.g. irrigation)
- C discharged effluent
- D screenings and grit
- E primary sludge
- F secondary sludge
- G tertiary sludge
- H digested sludge
- I digester gas
- J returned water from dewatering

**Figure 1 — Schematic diagram of wastewater treatment plants**

The primary application is for wastewater treatment plants designed for the treatment of domestic and municipal wastewater.

NOTE For requirements on pumping installations at wastewater treatment plants see EN 752, *Drain and sewer systems outside buildings*, and EN 16932, *Drain and sewer systems outside buildings — Pumping systems*:

- Part 1: General requirements;
- Part 2: Positive pressure systems;
- Part 3: Vacuum systems.

## **1 Scope**

This document specifies performance requirements for treatment of wastewater using the activated sludge process for plants over 50 PT.

The informative Annexes A to W provide design information.

## **2 Normative references**

The following documents are referred to in the text in such a way that some or all of their content constitutes requirements of this document. For dated references, only the edition cited applies. For undated references, the latest edition of the referenced document (including any amendments) applies.

EN 16323, *Glossary of wastewater engineering terms*

EN 12255-1, *Wastewater treatment plants - Part 1: General construction principles*

EN 12255-10, *Wastewater treatment plants - Part 10: Safety principles*

EN 12255-11, *Wastewater treatment plants - Part 11: General data required*

EN 12255-12, *Wastewater treatment plants - Part 12: Control and automation*

**koniec náhľadu – text ďalej pokračuje v platenej verzii STN**