

<b>STN</b>	<b>Zdravnotechnické armatúry Jednoduché výtokové armatúry a zmiešavacie batérie pre systémy zásobovania vodou typu 1 a typu 2 Všeobecné technické podmienky</b>	<b>STN EN 200</b>  13 7105
------------	---	--------------------------------------

Sanitary tapware - Single taps and combination taps for water supply systems of type 1 and type 2 - General technical specification

Táto norma obsahuje anglickú verziu európskej normy.  
This standard includes the English version of the European Standard.

Táto norma bola oznámená vo Vestníku ÚNMS SR č. 03/24

Obsahuje: EN 200:2023

Oznámením tejto normy sa ruší  
STN EN 200 (13 7105) z februára 2009

**138260**

Úrad pre normalizáciu, metrológiu a skúšobníctvo Slovenskej republiky, 2024  
Slovenská technická norma a technická normalizačná informácia je chránená zákonom č. 60/2018 Z. z. o technickej normalizácii v znení neskorších predpisov.

EUROPEAN STANDARD

**EN 200**

NORME EUROPÉENNE

EUROPÄISCHE NORM

December 2023

ICS 91.140.70

Supersedes EN 200:2008

English Version

## Sanitary tapware - Single taps and combination taps for water supply systems of type 1 and type 2 - General technical specification

Robinetterie sanitaire - Robinets simples et mélangeurs pour les systèmes d'alimentation en eau des types 1 et 2 - Spécifications techniques générales

Sanitärarmaturen - Auslaufventile und Mischbatterien für Wasserversorgungssysteme vom Typ 1 und Typ 2 - Allgemeine technische Spezifikation

This European Standard was approved by CEN on 27 November 2023.

CEN members are bound to comply with the CEN/CENELEC Internal Regulations which stipulate the conditions for giving this European Standard the status of a national standard without any alteration. Up-to-date lists and bibliographical references concerning such national standards may be obtained on application to the CEN-CENELEC Management Centre or to any CEN member.

This European Standard exists in three official versions (English, French, German). A version in any other language made by translation under the responsibility of a CEN member into its own language and notified to the CEN-CENELEC Management Centre has the same status as the official versions.

CEN members are the national standards bodies of Austria, Belgium, Bulgaria, Croatia, Cyprus, Czech Republic, Denmark, Estonia, Finland, France, Germany, Greece, Hungary, Iceland, Ireland, Italy, Latvia, Lithuania, Luxembourg, Malta, Netherlands, Norway, Poland, Portugal, Republic of North Macedonia, Romania, Serbia, Slovakia, Slovenia, Spain, Sweden, Switzerland, Türkiye and United Kingdom.



EUROPEAN COMMITTEE FOR STANDARDIZATION  
COMITÉ EUROPÉEN DE NORMALISATION  
EUROPÄISCHES KOMITEE FÜR NORMUNG

**CEN-CENELEC Management Centre: Rue de la Science 23, B-1040 Brussels**

**EN 200:2023 (E)**

<b>Contents</b>	<b>Page</b>
European foreword .....	7
Introduction .....	8
<b>1 Scope.....</b>	<b>9</b>
<b>2 Normative references.....</b>	<b>11</b>
<b>3 Terms and definitions.....</b>	<b>12</b>
<b>4 Designation .....</b>	<b>15</b>
<b>5 Marking and identification.....</b>	<b>16</b>
<b>5.1 Marking .....</b>	<b>16</b>
<b>5.2 Identification .....</b>	<b>16</b>
<b>5.2.1 Identification of inlets.....</b>	<b>16</b>
<b>5.2.2 Identification of flow controls equipment.....</b>	<b>16</b>
<b>6 Materials .....</b>	<b>17</b>
<b>6.1 Chemical and hygiene requirements.....</b>	<b>17</b>
<b>6.2 Exposed surface condition and quality of coating .....</b>	<b>17</b>
<b>7 Backflow protection.....</b>	<b>17</b>
<b>8 Sequence of testing.....</b>	<b>17</b>
<b>9 Dimensional characteristics .....</b>	<b>17</b>
<b>9.1 General remarks .....</b>	<b>17</b>
<b>9.2 Inlet dimensions.....</b>	<b>18</b>
<b>9.3 Outlet dimensions.....</b>	<b>20</b>
<b>9.4 Mounting dimensions.....</b>	<b>24</b>
<b>9.5 Special cases .....</b>	<b>26</b>
<b>10 Leaktightness characteristics.....</b>	<b>27</b>
<b>10.1 Principle.....</b>	<b>27</b>
<b>10.2 Apparatus .....</b>	<b>27</b>
<b>10.3 Leaktightness of the obturator and of the tap upstream of the obturator(s) with the   obturator in the closed position.....</b>	<b>27</b>
<b>10.3.1 Procedure .....</b>	<b>27</b>
<b>10.3.2 Requirements.....</b>	<b>27</b>
<b>10.4 Leaktightness downstream of the obturator .....</b>	<b>27</b>
<b>10.4.1 General.....</b>	<b>27</b>
<b>10.4.2 Procedure .....</b>	<b>27</b>
<b>10.4.3 Requirements.....</b>	<b>28</b>
<b>10.5 Leaktightness of manually operated diverters.....</b>	<b>28</b>
<b>10.5.1 General.....</b>	<b>28</b>
<b>10.5.2 Procedure .....</b>	<b>28</b>
<b>10.5.3 Procedure where an outlet(s) cannot be artificially closed – products for type 1 systems</b>	<b>28</b>
<b>10.5.4 Procedure where an outlet(s) cannot be artificially closed – products for type 2 systems</b>	<b>29</b>
<b>10.5.5 Requirements.....</b>	<b>29</b>
<b>10.6 Leaktightness and operation of diverters with automatic return (and semi-automatic type   diverters).....</b>	<b>29</b>
<b>10.6.1 General.....</b>	<b>29</b>
<b>10.6.2 Procedure – products for Type 1 systems.....</b>	<b>29</b>

10.6.3	Procedure – products for Type 2 systems .....	30
10.6.4	Requirements.....	31
11	Pressure resistance.....	33
11.1	Principle.....	33
11.2	Apparatus.....	33
11.3	Mechanical behaviour upstream of the obturator – obturator in the closed position.....	33
11.3.1	Procedure.....	33
11.3.2	Requirement.....	33
11.4	Mechanical behaviour downstream of the obturator – obturator in the open position.....	33
11.4.1	Procedure for products for type 1 systems.....	33
11.4.2	Procedure for products for type 2 systems.....	33
11.4.3	Requirement.....	34
12	Hydraulic performance .....	34
12.1	General .....	34
12.2	Determination of flow rate – products for type 1 systems .....	35
12.2.1	Principle.....	35
12.2.2	Apparatus .....	35
12.2.3	Procedure .....	35
12.2.4	Requirements.....	35
12.3	Determination of flow rate – products for type 2 systems .....	36
12.3.1	Principle.....	36
12.3.2	Apparatus .....	36
12.3.3	Procedure .....	37
12.3.4	Requirements.....	37
13	Mechanical strength/torsional resistance .....	38
13.1	Principle.....	38
13.2	Apparatus .....	38
13.3	Test piece.....	38
13.4	Procedure .....	38
13.5	Requirements.....	38
14	Mechanical endurance .....	38
14.1	General .....	38
14.2	Endurance test for on/off flow control devices operated by rotating the control handle.....	39
14.2.1	Principle.....	39
14.2.2	Apparatus.....	39
14.2.3	Procedure .....	39
14.2.4	Requirement.....	41
14.3	Endurance test for other on/off flow control devices .....	42
14.3.1	Principle.....	42
14.3.2	Apparatus.....	42
14.3.3	Procedure .....	42
14.3.4	Requirement.....	42
14.4	Endurance of manually operated diverters .....	42
14.4.1	Principle.....	42
14.4.2	Apparatus .....	43
14.4.3	Procedure .....	43
14.4.4	Requirement.....	43
14.5	Endurance of diverters with automatic return.....	43
14.5.1	Principle.....	43
14.5.2	Apparatus .....	43
14.5.3	Procedure .....	44

**EN 200:2023 (E)**

<b>14.5.4 Requirement</b> .....	<b>44</b>
<b>14.6 Endurance test for swivel spouts</b> .....	<b>45</b>
<b>14.6.1 Principle</b> .....	<b>45</b>
<b>14.6.2 Apparatus</b> .....	<b>45</b>
<b>14.6.3 Procedure for single outlet type</b> .....	<b>45</b>
<b>14.6.4 Procedure for divided outlet type</b> .....	<b>45</b>
<b>14.6.5 Requirements</b> .....	<b>46</b>
<b>15 Acoustic characteristics — products for type 1 systems only</b> .....	<b>47</b>
<b>15.1 General</b> .....	<b>47</b>
<b>15.2 Procedure</b> .....	<b>47</b>
<b>15.2.1 Flow rate class of sanitary tapware products (with appropriate acoustic information)</b> ...	<b>47</b>
<b>15.2.2 Flow rate class of sanitary tapware products (without appropriate acoustic information)</b>	<b>47</b>
<b>15.3 Expression of results</b> .....	<b>47</b>
<b>15.3.1 Determination of acoustic group</b> .....	<b>48</b>
<b>15.3.2 Correspondence between flow rate classes and measurements</b> .....	<b>48</b>
<b>Annex A (informative) Pressure take-off tee</b> .....	<b>49</b>
<b>Annex B (informative) Minimum flow rates and test pressures according to application</b> .....	<b>52</b>
<b>Annex C (informative) Product components (detailed by other standards)</b> .....	<b>53</b>
<b>Bibliography</b> .....	<b>54</b>

## Figures

Figure 1 — Supply system of Type 1 with a pressure range of (0,05 to 1,0) MPa [(0,5 to 10) bar]	10
Figure 2 — Supply system of Type 2 with a pressure range of (0,01 to 1,0) MPa [(0,1 to 10) bar]	11
Figure 3 — Bib taps 1/2 and 3/4 - single hole taps	19
Figure 4 — Multi hole combination taps	20
Figure 5 — Supply connections for taps and remote outlets	20
Figure 6 — Pillar and bib taps	22
Figure 7 — Remote outlet	22
Figure 8 — Single hole combination tap/remote outlet	23
Figure 9 — Bath/shower combination tap/remote outlet	23
Figure 10 — Single hole taps	25
Figure 11 — Two-hole tap (fixed centres)	26
Figure 12 — Three-hole tap (adjustable centres)	26
Figure 13 — Clamping Arrangement for use with ceramic sanitaryware	26
Figure 14 — Apparatus for testing the leaktightness of automatic diverters for taps for supply system of Type 2	31
Figure 15 — Flow rate test apparatus for sanitary tapware for Type 2 systems	37
Figure 16 — Life test -closing torque vs time	41
Figure 17 — Endurance test rig for divided-outlet swivel spout	46
Figure A.1 — Pressure take-off tee (test rig Type 1 taps)	49
Figure A.2 — Schematic examples of pressure take-off tees (test rig Type 1 taps)	51

## Tables

Table 1 — Conditions of use	9
Table 2 — Designation	15
Table 3 — Sequence of testing	17
Table 4 — Inlet dimensions sanitary tapware	18
Table 5 — Outlet dimensions	21
Table 6 — Mounting dimensions	24
Table 7 — Informative summary of leaktightness tests	32
Table 8 — Informative summary of pressure resistance tests	34
Table 9 — Informative summary of test conditions for on/off flow control devices	40
Table 10 — Informative summary of test conditions for diverters	44
Table 11 — Informative summary of test conditions for swivel spout	47
Table 12 — Acoustic group	48

**EN 200:2023 (E)**

<b>Table 13 — Flow rate classes (EN ISO 3822-4).....</b>	<b>48</b>
<b>Table A.1 — Dimensions of the pressure take-off tee.....</b>	<b>50</b>
<b>Table B.1 —Recommended flow rates for domestic use.....</b>	<b>52</b>

## European foreword

This document (EN 200:2023) has been prepared by Technical Committee CEN/TC 164 “Water supply”, the secretariat of which is held by AFNOR.

This European Standard shall be given the status of a national standard, either by publication of an identical text or by endorsement, at the latest by June 2024, and conflicting national standards shall be withdrawn at the latest by June 2024.

Attention is drawn to the possibility that some of the elements of this document may be the subject of patent rights. CEN shall not be held responsible for identifying any or all such patent rights.

This document supersedes EN 200:2008.

In comparison with the previous edition, the following technical modifications have been made:

- all test of hydraulic performance, acoustic characteristics and leaktightness were completely revised;
- figures, tables and dimensions were revised;
- normative references were updated;
- editorial changes have been made throughout the entire document.

This document acknowledges the field of application of tapware used in:

- water supply systems of Type 1 (see Figure 1 and Table 1) with a pressure range of 0,05 MPa (0,5 bar) to 1,0 MPa (10 bar);
- water supply systems of Type 2 (see Figure 2 and Table 1) with a pressure range of 0,01 MPa (0,1 bar) to 1,0 MPa (10 bar) – which combines mains-fed and cistern-fed water supply systems.

Any feedback and questions on this document should be directed to the users’ national standards body. A complete listing of these bodies can be found on the CEN website.

According to the CEN-CENELEC Internal Regulations, the national standards organisations of the following countries are bound to implement this European Standard: Austria, Belgium, Bulgaria, Croatia, Cyprus, Czech Republic, Denmark, Estonia, Finland, France, Germany, Greece, Hungary, Iceland, Ireland, Italy, Latvia, Lithuania, Luxembourg, Malta, Netherlands, Norway, Poland, Portugal, Republic of North Macedonia, Romania, Serbia, Slovakia, Slovenia, Spain, Sweden, Switzerland, Türkiye and the United Kingdom.



**EN 200:2023 (E)****Introduction**

In respect of potential adverse effects on the quality of water intended for human consumption, caused by the product covered by this document.

This document provides no information as to whether the product can be used without restriction in any of the Member States of the EU or EFTA.

It should be noted that, while awaiting the adoption of verifiable European criteria, existing national regulations concerning the use and/or the characteristics of these products remain in force.

This document identifies characteristics and technical requirements for single and combination taps.

## 1 Scope

This document specifies:

- a) the field of application for pillar taps, bib taps, single and multi-hole combination taps for use in:
- 1) a supply system of Type 1 (see Figure 1) with a pressure range of (0,05 to 1,0) MPa [(0,5 to 10) bar];
  - 2) a supply system of Type 2 (see Figure 2) with a pressure range of (0,01 to 1,0) MPa [(0,1 to 10) bar];
- b) the dimensional, leak tightness, pressure resistance, hydraulic performance, mechanical strength, endurance, corrosion resistance of the surface of the product, sequence of testing and acoustic characteristics with which sanitary tapware products including their components (flexible hose, pullout spray) need to comply where applicable;
- c) test methods to verify the characteristics.

The tests described in this document are type tests (laboratory tests) and not quality control or factory production control (FPC) tests carried out during manufacture.

This document is applicable to draw-off taps (single taps and combination taps) for use with sanitary appliances installed in rooms used for personal hygiene (cloakrooms, bathrooms etc.) and for food preparation (kitchens), i.e. for use with baths, basins, bidets, showers and sinks.

This document applies to sanitary draw-off taps of nominal size 3/8", 1/2", 3/4" and 1" (PN 10).

The conditions of use and classifications are given in Table 1.

**Table 1 — Conditions of use**

Water supply system	Operating range of taps	
	Limits	Recommended
Type 1 see Figure 1	<u>Dynamic Pressure</u> $\geq 0,05$ MPa (0,5 bar) <u>Static Pressure</u> $\leq 1,0$ MPa (10,0 bar)	<u>Dynamic Pressure</u> (0,1 to 0,5) MPa [(1,0 to 5,0) bar]
Type 2 see Figure 2	<u>Dynamic Pressure</u> $\geq 0,01$ MPa (0,1 bar) <u>Static Pressure</u> $\leq 1,0$ MPa (10,0 bar)	<u>Dynamic Pressure</u> <sup>a</sup> (0,02 to 0,1) MPa [(0,2 to 1,0) bar]
Temperature	$\leq 70$ °C	$\leq 65$ °C

<sup>a</sup> Low pressure sanitary tapware complying with this standard may also be used with inlet supply pressures in the range from 0,1 MPa to 0,2 MPa (1,0 bar to 2,0 bar) on condition that acoustic performance is not a requirement of the installation.

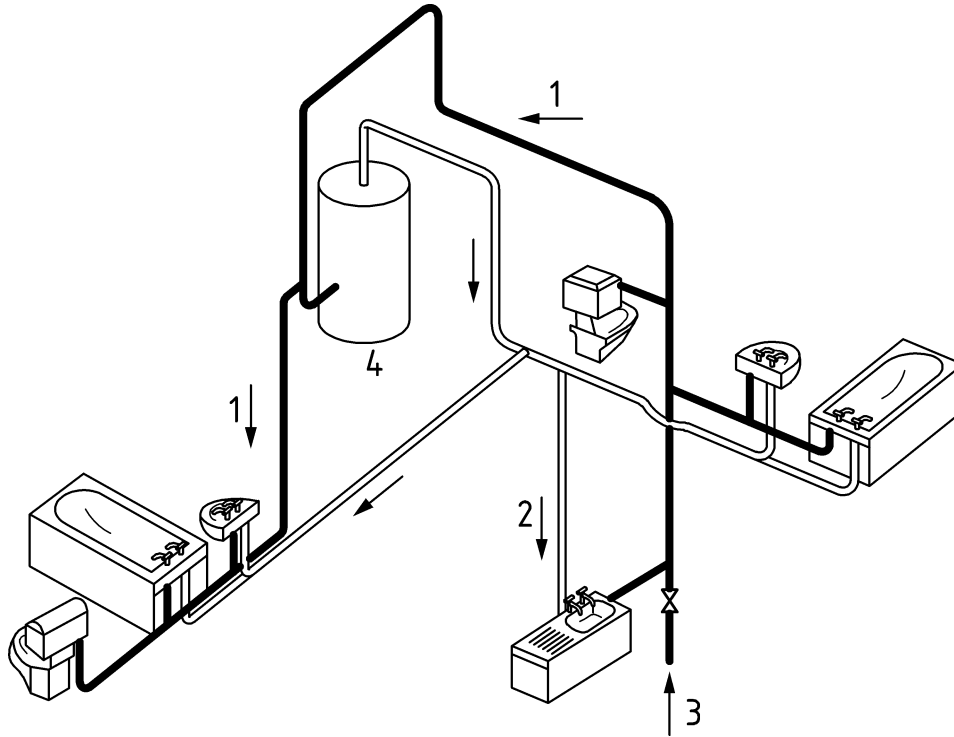
**EN 200:2023 (E)****Key**

- 1 cold water
- 2 hot water
- 3 mains supply pipe (supply pressures up to 10 bar)
- 4 water heater

**Figure 1 — Supply system of Type 1 with a pressure range of (0,05 to 1,0) MPa [(0,5 to 10) bar]**

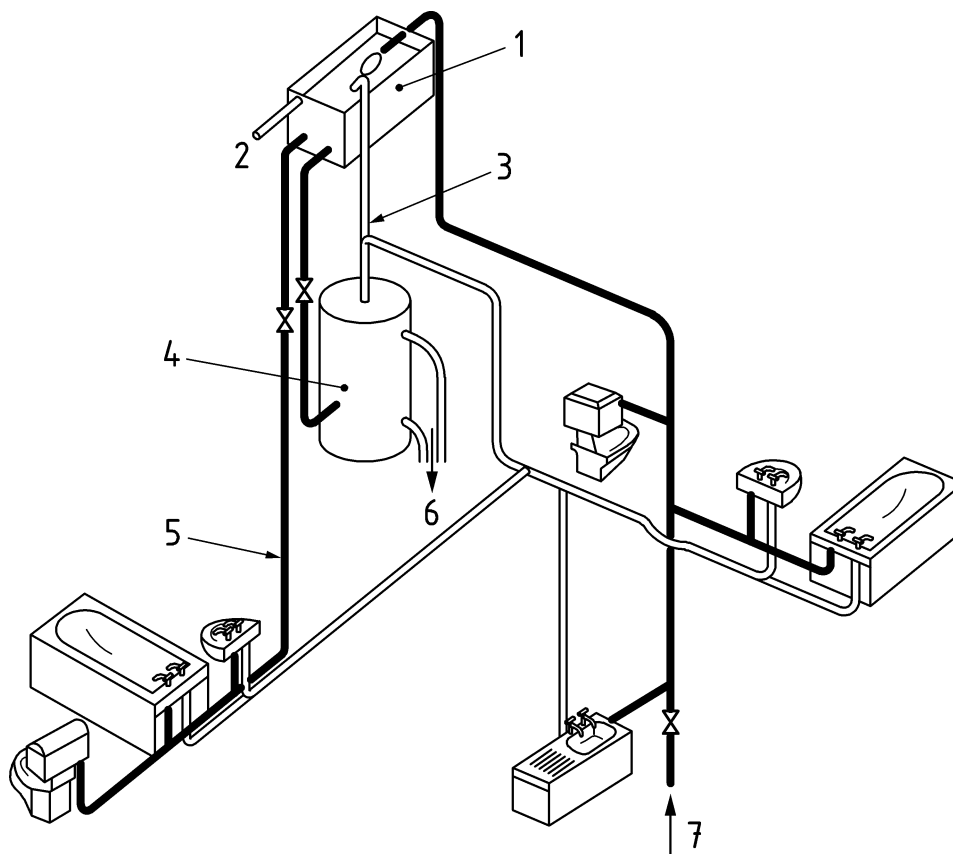
**Key**

- 1 cold water storage cistern (cover omitted for clarity)
- 2 warning pipe
- 3 vent pipe
- 4 hot water cylinder
- 5 alternative cistern fed cold supply to sanitary appliances
- 6 to boiler
- 7 mains supply pipe (supply pressures up to 10 bar)

**Figure 2 — Supply system of Type 2 with a pressure range of (0,01 to 1,0) MPa [(0,1 to 10) bar]**

NOTE Components which are part or can be delivered with sanitary tapware products are listed in Annex C.

Final materials included in the product are not covered by this document.

## 2 Normative references

The following documents are referred to in the text in such a way that some or all of their content constitutes requirements of this document. For dated references, only the edition cited applies. For undated references, the latest edition of the referenced document (including any amendments) applies.

EN 246, *Sanitary tapware — General specifications for aerators*

EN 248, *Sanitary tapware — General specification for electrodeposited coatings of Ni-Cr*

EN 1057, *Copper and copper alloys — Seamless, round copper tubes for water and gas in sanitary and heating applications*

**EN 200:2023 (E)**

EN 1717, *Protection against pollution of potable water in water installations and general requirements of devices to prevent pollution by backflow*

EN 13618, *Flexible hose assemblies in drinking water installations — Functional requirements and test methods*

EN 13959, *Anti-pollution check valves — DN 6 to DN 250 inclusive family E, type A, B, C and D*

EN 14506, *Devices to prevent pollution by backflow of potable water — Automatic diverter — Family H, type C*

EN ISO 228-1, *Pipe threads where pressure-tight joints are not made on the threads — Part 1: Dimensions, tolerances and designation (ISO 228-1)*

EN ISO 3822-1, *Acoustics — Laboratory tests on noise emission from appliances and equipment used in water supply installations — Part 1: Method of measurement (ISO 3822-1)*

EN ISO 3822-2, *Acoustics — Laboratory tests on noise emission from appliances and equipment used in water supply installations — Part 2: Mounting and operating conditions for draw-off taps and mixing valves (ISO 3822-2)*

EN ISO 3822-4, *Acoustics — Laboratory tests on noise emission from appliances and equipment used in water supply installations — Part 4: Mounting and operating conditions for special appliances*

**koniec náhľadu – text ďalej pokračuje v platenej verzii STN**