

STN	Čistiarne odpadových vôd Časť 8: Spracovanie a uskladnenie kalu	STN EN 12255-8 75 6410
------------	--	--

Wastewater treatment plants - Part 8: Sludge treatment and storage

Táto norma obsahuje anglickú verziu európskej normy.
This standard includes the English version of the European Standard.

Táto norma bola oznámená vo Vestníku ÚNMS SR č. 07/24

Rozpracovaná prekladom.

Obsahuje: EN 12255-8:2024

Oznámením tejto normy sa ruší
STN EN 12255-8 (75 6410) zo septembra 2003

138836

Úrad pre normalizáciu, metrológiu a skúšobníctvo Slovenskej republiky, 2024
Slovenská technická norma a technická normalizačná informácia je chránená zákonom č. 60/2018 Z. z. o technickej normalizácii v znení neskorších predpisov.

EUROPEAN STANDARD

EN 12255-8

NORME EUROPÉENNE

EUROPÄISCHE NORM

May 2024

ICS 13.060.30

Supersedes EN 12255-8:2001

English Version

Wastewater treatment plants - Part 8: Sludge treatment and storage

Stations d'épuration - Partie 8 : Stockage et traitement des boues

Kläranlagen - Teil 8: Schlammbehandlung und -lagerung

This European Standard was approved by CEN on 27 February 2024.

CEN members are bound to comply with the CEN/CENELEC Internal Regulations which stipulate the conditions for giving this European Standard the status of a national standard without any alteration. Up-to-date lists and bibliographical references concerning such national standards may be obtained on application to the CEN-CENELEC Management Centre or to any CEN member.

This European Standard exists in three official versions (English, French, German). A version in any other language made by translation under the responsibility of a CEN member into its own language and notified to the CEN-CENELEC Management Centre has the same status as the official versions.

CEN members are the national standards bodies of Austria, Belgium, Bulgaria, Croatia, Cyprus, Czech Republic, Denmark, Estonia, Finland, France, Germany, Greece, Hungary, Iceland, Ireland, Italy, Latvia, Lithuania, Luxembourg, Malta, Netherlands, Norway, Poland, Portugal, Republic of North Macedonia, Romania, Serbia, Slovakia, Slovenia, Spain, Sweden, Switzerland, Türkiye and United Kingdom.



EUROPEAN COMMITTEE FOR STANDARDIZATION
COMITÉ EUROPÉEN DE NORMALISATION
EUROPÄISCHES KOMITEE FÜR NORMUNG

CEN-CENELEC Management Centre: Rue de la Science 23, B-1040 Brussels

EN 12255-8:2024 (E)

Contents	Page
European foreword	4
Introduction	6
1 Scope.....	7
2 Normative references.....	7
3 Terms and definitions.....	7
4 Symbols and abbreviations	8
5 Planning	9
6 Processes	10
6.1 General.....	10
6.2 Sludge conditioning	10
6.2.1 Overview	10
6.2.2 Use of Polymers [14].....	10
6.2.3 Polymer storage and distribution.....	12
6.3 Sludge thickening.....	12
6.3.1 Process selection.....	12
6.3.2 Gravity thickening	13
6.3.3 Mechanical thickening	14
6.3.4 Dissolved air flotation.....	14
6.3.5 Overview of thickening systems.....	15
6.4 Disinfection.....	16
6.4.1 General.....	16
6.4.2 Thermal disinfection	17
6.4.3 Chemical disinfection	18
6.4.4 Other methods	18
6.4.5 Verification of disinfection success.....	18
6.5 Sludge pre-treatment prior to biological sludge stabilization	19
6.6 Biological Sludge Stabilization.....	19
6.6.1 General and stabilization requirements	19
6.6.2 Anaerobic sludge digestion	19
6.6.3 Aerobic sludge digestion	25
6.6.4 Sludge composting.....	25
6.6.5 Pseudo-stabilization	26
6.7 Sludge dewatering.....	26
6.7.1 Sludge drying beds	26
6.7.2 Mechanical sludge dewatering.....	26
6.8 Sludge drying [18]	29
6.8.1 General.....	29
6.8.2 Belt dryers.....	30
6.8.3 Solar and additionally heated solar dryers.....	31
6.9 Sludge handling and storage.....	33
6.9.1 General.....	33
6.9.2 Liquid sludge holding tanks.....	33
6.9.3 Sludge lagoons	33
6.9.4 Dewatered sludge storage areas	33

6.9.5	Dewatered or dry sludge silos	34
7	Components.....	34
7.1	Service life.....	34
7.2	Sludge pipelines	34
7.3	Sludge pumps.....	34
8	Health and safety	35
Annex A	(informative) Other guidance and information	36
A.1	Process checks.....	36
A.2	Sludge pre-treatment prior to biological sludge stabilization.....	36
A.2.1	Sludge disintegration	36
A.2.2	Biological hydrolysis	39
A.2.3	Recommendations.....	39
A.3	Basic sludge characteristics.....	40
A.3.1	General	40
A.3.2	Further sludge characteristics.....	41
A.4	Methods to optimize the polymer consumption	42
A.5	Methods to predict dewatering performance	42
	Bibliography	44

EN 12255-8:2024 (E)**European foreword**

This document (EN 12255-8:2024) has been prepared by Technical Committee CEN/TC 165 “Wastewater engineering”, the secretariat of which is held by DIN.

This European Standard shall be given the status of a national standard, either by publication of an identical text or by endorsement, at the latest by November 2024, and conflicting national standards shall be withdrawn at the latest by November 2024.

Attention is drawn to the possibility that some of the elements of this document may be the subject of patent rights. CEN shall not be held responsible for identifying any or all such patent rights.

This document supersedes EN 12255-8:2001.

The main changes compared to the previous edition EN 12255-8:2001 are listed below:

- a) comprehensive revision and additions in all sections;
- b) addition of design recommendations;
- c) addition of sludge drying systems;
- d) adaptation to the current state of the art;
- d) updating of the Normative references;
- e) editorial revision.

It is the eighth part prepared by Working Group CEN/TC 165/WG 40 relating to the general requirements and processes for treatment plants for a total number of inhabitants and population equivalents (PT) over 50. EN 12255 with the generic title “*Wastewater treatment plants*” consists of the following Parts:

- *Part 1: General construction principles*
- *Part 2: Storm management systems*
- *Part 3: Preliminary treatment*
- *Part 4: Primary treatment*
- *Part 5: Lagooning processes*
- *Part 6: Activated sludge process*
- *Part 7: Biological fixed-film reactors*
- *Part 8: Sludge treatment and storage*
- *Part 9: Odour control and ventilation*
- *Part 10: Safety principles*
- *Part 11: General data required*

- *Part 12: Control and automation*
- *Part 13: Chemical treatment — Treatment of wastewater by precipitation/flocculation*
- *Part 14: Disinfection*
- *Part 15: Measurement of the oxygen transfer in clean water in aeration tanks of activated sludge plants*
- *Part 16: Physical (mechanical) filtration*

NOTE 1 Part 2 is under preparation.

NOTE 2 For requirements on pumping installations at wastewater treatment plants see EN 752 and EN 16932 (all parts).

Any feedback and questions on this document should be directed to the users' national standards body. A complete listing of these bodies can be found on the CEN website.

According to the CEN-CENELEC Internal Regulations, the national standards organisations of the following countries are bound to implement this European Standard: Austria, Belgium, Bulgaria, Croatia, Cyprus, Czech Republic, Denmark, Estonia, Finland, France, Germany, Greece, Hungary, Iceland, Ireland, Italy, Latvia, Lithuania, Luxembourg, Malta, Netherlands, Norway, Poland, Portugal, Republic of North Macedonia, Romania, Serbia, Slovakia, Slovenia, Spain, Sweden, Switzerland, Türkiye and the United Kingdom.

EN 12255-8:2024 (E)**Introduction**

Differences in wastewater treatment throughout Europe have led to a variety of systems being developed. This document gives fundamental information about the systems; this document has not attempted to specify all available systems. A generic arrangement of wastewater treatment plants is illustrated below in Figure 1.

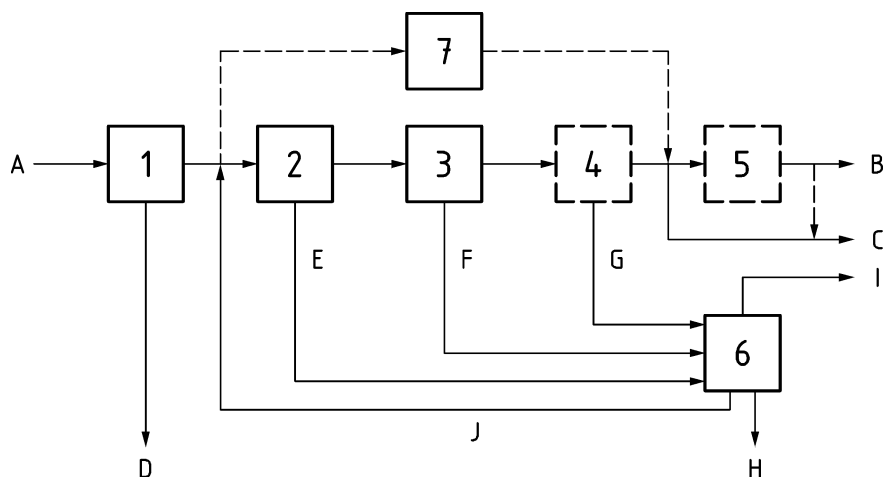
**Key**

- 1 preliminary treatment
- 2 primary treatment
- 3 secondary treatment
- 4 tertiary treatment
- 5 additional treatment (e.g. disinfection or removal of micropollutants)
- 6 sludge treatment
- 7 lagoons (as an alternative)
- A raw wastewater
- B effluent for re-use (e.g. irrigation)
- C discharged effluent
- D screenings and grit
- E primary sludge
- F secondary sludge
- G tertiary sludge
- H stabilized sludge
- I digester gas
- J returned water from dewatering

Figure 1 — Schematic diagram of wastewater treatment plants

Detailed information additional to that contained in this document can be obtained by referring to the bibliography.

The primary application is for wastewater treatment plants designed for the treatment of domestic and municipal wastewater.

1 Scope

This document specifies design principles and performance requirements for sludge treatment and storage facilities at wastewater treatment plants serving more than 50 PT.

Guidance on operation is provided where it is necessary in order to facilitate the design of control and automation and design access to points of operation.

NOTE Other sludges and organic wastes can be treated together with municipal sewage sludge where national and local regulations permit.

2 Normative references

The following documents are referred to in the text in such a way that some or all of their content constitutes requirements of this document. For dated references, only the edition cited applies. For undated references, the latest edition of the referenced document (including any amendments) applies.

EN 12255-9, *Wastewater treatment plants — Part 9: Odour control and ventilation*

EN 12255-10, *Wastewater treatment plants — Part 10: Safety principles*

koniec náhľadu – text ďalej pokračuje v platenej verzii STN