

<b>STN</b>	<b>Plynárenská infraštruktúra Vstrekovacie stanice Časť 1: Všeobecné požiadavky</b>	<b>STN EN 17928-1</b>  38 6421
------------	---	--

Gas infrastructure - Injection stations - Part 1: General requirements

Táto norma obsahuje anglickú verziu európskej normy.  
This standard includes the English version of the European Standard.

Táto norma bola oznámená vo Vestníku ÚNMS SR č. 11/24

Obsahuje: EN 17928-1:2024

**139625**

---

Úrad pre normalizáciu, metrológiu a skúšobníctvo Slovenskej republiky, 2024  
Slovenská technická norma a technická normalizačná informácia je chránená zákonom č. 60/2018 Z. z. o technickej normalizácii  
v znení neskorších predpisov.

EUROPEAN STANDARD

EN 17928-1

NORME EUROPÉENNE

EUROPÄISCHE NORM

October 2024

ICS 75.200

English Version

## Gas infrastructure - Injection stations - Part 1: General requirements

Infrastructures gazières - Stations d'injection - Partie 1  
: Exigences générales

Gasinfrastruktur - Einspeiseanlagen - Teil 1:  
Allgemeine Anforderungen

This European Standard was approved by CEN on 7 July 2024.

CEN members are bound to comply with the CEN/CENELEC Internal Regulations which stipulate the conditions for giving this European Standard the status of a national standard without any alteration. Up-to-date lists and bibliographical references concerning such national standards may be obtained on application to the CEN-CENELEC Management Centre or to any CEN member.

This European Standard exists in three official versions (English, French, German). A version in any other language made by translation under the responsibility of a CEN member into its own language and notified to the CEN-CENELEC Management Centre has the same status as the official versions.

CEN members are the national standards bodies of Austria, Belgium, Bulgaria, Croatia, Cyprus, Czech Republic, Denmark, Estonia, Finland, France, Germany, Greece, Hungary, Iceland, Ireland, Italy, Latvia, Lithuania, Luxembourg, Malta, Netherlands, Norway, Poland, Portugal, Republic of North Macedonia, Romania, Serbia, Slovakia, Slovenia, Spain, Sweden, Switzerland, Türkiye and United Kingdom.



EUROPEAN COMMITTEE FOR STANDARDIZATION  
COMITÉ EUROPÉEN DE NORMALISATION  
EUROPÄISCHES KOMITEE FÜR NORMUNG

**CEN-CENELEC Management Centre: Rue de la Science 23, B-1040 Brussels**

## EN 17928-1:2024 (E)

<b>Contents</b>	<b>Page</b>
European foreword.....	5
<b>1 Scope</b> .....	<b>6</b>
<b>2 Normative references</b> .....	<b>8</b>
<b>3 Terms and definitions</b> .....	<b>10</b>
<b>4 General requirements</b> .....	<b>14</b>
4.1 General.....	14
4.2 Quality and management system.....	14
4.3 Environmental constraints.....	15
4.3.1 General requirements.....	15
4.3.2 Adaptation to the effects of climate change.....	15
4.3.3 Mitigation of the impact of earthquakes.....	16
4.3.4 Greenhouse gas emissions.....	16
4.4 Coordination requirements and definition of interfaces.....	18
4.5 On-site station diagram.....	18
4.6 Explosion protection.....	18
<b>5 Operational functions</b> .....	<b>19</b>
5.1 Nominal service conditions of injection stations.....	19
5.2 Backflow and refeeding to upgrading and/or production.....	20
5.2.1 General requirements.....	20
5.2.2 Backflow from an injection station.....	20
5.2.3 Process-related controlled refeeding.....	20
<b>6 Overall safety requirements and protection against inadmissible operating modes</b> .....	<b>20</b>
6.1 General requirements.....	20
6.2 Emergency energy supply.....	21
6.3 Approach to protection against inadmissible operating modes.....	21
6.4 Safety-related systems.....	22
6.4.1 General requirements.....	22
6.4.2 SIS safety-related systems.....	22
6.4.3 Mechanical/pneumatic safety-related systems.....	23
6.5 Injection station emergency shut-off.....	23
6.6 Protections against inadmissible operation modes by safety-related systems.....	23
6.6.1 Protection against inadmissible overpressure.....	23
6.6.2 Protection against inadmissible under-pressure.....	24
6.6.3 Protection against inadmissible gas temperatures.....	24
6.6.4 Protection against potentially explosive atmospheres.....	24
6.6.5 Protection against overflow and underflow.....	24
6.6.6 Protection against inadmissible composition of the injection of gas.....	24
6.6.7 Protection against use/ageing/corrosion.....	25
6.7 Information security.....	25
<b>7 Specific requirements for systems and components</b> .....	<b>25</b>
7.1 Common requirements.....	25
7.2 Systems.....	25
7.2.1 Compression system.....	25
7.2.2 Pressure control systems.....	26

7.2.3	Gas analysis system.....	26
7.2.4	Gas measuring systems .....	28
7.2.5	Gas-Gas mixing system .....	28
7.2.6	Odorization systems.....	30
7.2.7	Deodorisation systems .....	30
7.3	Components.....	30
7.3.1	Mechanical safety devices for protection against inadmissible over- and underpressure .....	30
7.3.2	Isolation valves.....	30
7.3.3	Pipework.....	30
7.3.4	Pressure vessels.....	31
7.3.5	Function test equipment.....	31
8	Building and layout requirement .....	32
8.1	General .....	32
8.1.1	Transport and escape routes.....	32
8.1.2	Noise control .....	32
8.1.3	Isolation of gas flow outside of the place of installation .....	32
8.1.4	Working areas.....	33
8.1.5	Protection against harmful external influences.....	33
8.1.6	Safety marking.....	33
8.2	Indoor Housing.....	33
8.2.1	General .....	33
8.2.2	Installation in residential or commercial buildings .....	33
8.2.3	Openings .....	33
8.2.4	Ventilation.....	33
8.2.5	Walls, ceilings, roofs, and ducts.....	34
8.3	Outdoor Installation .....	34
8.3.1	Outdoor station design .....	34
9	Electrical requirements.....	34
9.1	Electrical equipment .....	34
9.2	Electrical resistance of floor coverings.....	34
9.3	Cable ducts .....	35
9.4	Isolating joints .....	35
9.5	Lightning protection and equipotential bonding.....	35
9.5.1	Protective equipotential bonding.....	35
9.5.2	External and internal lightning protection, lightning protective equipotential bonding.....	35
10	Testing.....	35
10.1	General requirements.....	35
10.2	Tests carried out by the manufacturer .....	36
10.3	Tests at the place of installation.....	36
10.3.1	General requirements.....	36
10.3.2	Compliance with safety-related approval and structural requirements .....	36
10.3.3	Connections to the station .....	36
10.3.4	Welds and Joints control .....	36
10.3.5	Tightness.....	37
10.3.6	Function and Setpoint.....	37
10.3.7	Explosion protection .....	37
10.4	Testing of electrical systems and equipment.....	37
10.5	Proof of testing .....	37
10.5.1	Testing by the manufacturer .....	37
10.5.2	Testing at the place of installation .....	38

**EN 17928-1:2024 (E)**

<b>10.5.3</b>	<b>Explosion protection testing</b> .....	<b>38</b>
<b>10.5.4</b>	<b>Testing of electrical systems and equipment</b> .....	<b>38</b>
<b>10.5.5</b>	<b>Testing documentation</b> .....	<b>38</b>
<b>11</b>	<b>Commissioning</b> .....	<b>38</b>
<b>12</b>	<b>Operation and maintenance</b> .....	<b>39</b>
<b>12.1</b>	<b>General</b> .....	<b>39</b>
<b>12.2</b>	<b>Data</b> .....	<b>39</b>
<b>12.3</b>	<b>Maintenance, modifications and repair</b> .....	<b>39</b>
<b>12.4</b>	<b>Training</b> .....	<b>40</b>
<b>12.5</b>	<b>Work undertaken</b> .....	<b>40</b>
<b>12.6</b>	<b>Fire fighting</b> .....	<b>41</b>
<b>13</b>	<b>Decommissioning and disposal</b> .....	<b>41</b>
<b>13.1</b>	<b>Decommissioning</b> .....	<b>41</b>
<b>13.2</b>	<b>Disposal</b> .....	<b>41</b>
<b>Annex A (informative)</b>	<b>Coordination between operators</b> .....	<b>42</b>
<b>Annex B (informative)</b>	<b>Compression system specification data sheet</b> .....	<b>44</b>
<b>Annex C (informative)</b>	<b>Test schedule</b> .....	<b>46</b>
<b>Annex D (normative)</b>	<b>Test ratings in accordance with Clause 11</b> .....	<b>50</b>
<b>Annex E (informative)</b>	<b>Refeeding station</b> .....	<b>51</b>
<b>Annex F (normative)</b>	<b>Mitigation of the impact of earthquakes</b> .....	<b>52</b>
<b>Annex G (informative)</b>	<b>Typical Gas Mixing Plants — Examples</b> .....	<b>53</b>
<b>Annex H (informative)</b>	<b>Categories of methane emissions in the scope of this document</b> .....	<b>57</b>
<b>Bibliography</b>	.....	<b>58</b>

## European foreword

This document (EN 17928-1:2024) has been prepared by Technical Committee CEN/TC 234 “Gas infrastructure”, the secretariat of which is held by DIN.

This European Standard shall be given the status of a national standard, either by publication of an identical text or by endorsement, at the latest by April 2025, and conflicting national standards shall be withdrawn at the latest by April 2025.

Attention is drawn to the possibility that some of the elements of this document may be the subject of patent rights. CEN shall not be held responsible for identifying any or all such patent rights.

This document is part of the EN 17928 series, *Gas infrastructure — Injection stations*, which includes the following parts:

- *Part 1: General requirements*
- *Part 2: Specific requirements regarding the injection of biomethane*
- *Part 3: Specific requirements regarding the injection of hydrogen*

Any feedback and questions on this document should be directed to the users’ national standards body. A complete listing of these bodies can be found on the CEN website.

According to the CEN-CENELEC Internal Regulations, the national standards organisations of the following countries are bound to implement this European Standard: Austria, Belgium, Bulgaria, Croatia, Cyprus, Czech Republic, Denmark, Estonia, Finland, France, Germany, Greece, Hungary, Iceland, Ireland, Italy, Latvia, Lithuania, Luxembourg, Malta, Netherlands, Norway, Poland, Portugal, Republic of North Macedonia, Romania, Serbia, Slovakia, Slovenia, Spain, Sweden, Switzerland, Türkiye and the United Kingdom.

## EN 17928-1:2024 (E)

### 1 Scope

This document establishes the functional requirements for stations for the injection of biomethane, substitute natural gas (SNG) and hydrogen into gas transmission and distribution systems operated with gases (natural gas, biomethane, SNG, hydrogen, gas mixtures) in accordance with European technical rules that ensure the interoperability of systems.

Figure 1 describes the general approach including all the relevant functions that can be installed in different configurations. The injection of Hydrogen is covered separately in EN 17928-3:2024.

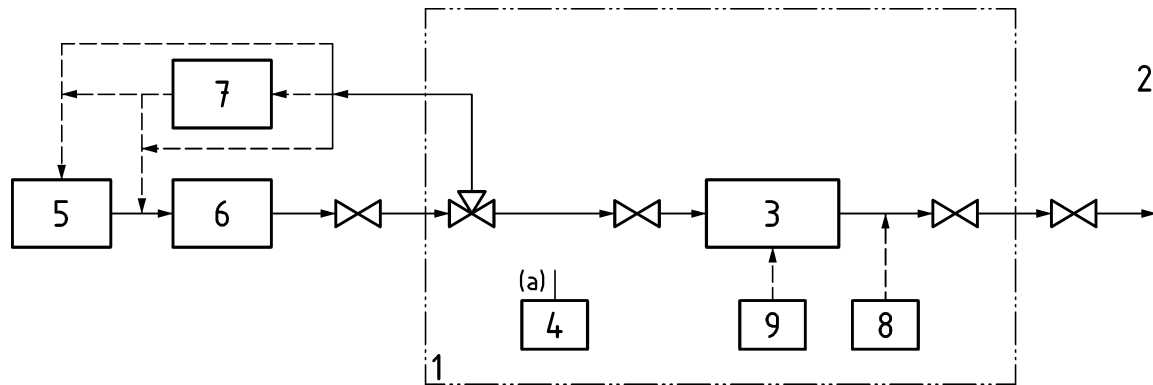

#### Key

- 1 injection station – scope of this document
- 2 gas transmission or distribution system
- 3 measuring and control station – pressure regulation/ compression/gas mixing / flow control
- 4 gas analysis and sampling system
- 5 gas production
- 6 gas purification/upgrading
- 7 storage
- 8 odorization (optional)
- 9 adjusting gases (optional) (see 7.2.5)
- (a) sampling unit to be connected to process line

**Figure 1 — Example of an injection station with gas purification**

This document also applies to refeeding stations that feed such gases back into upstream gas supply networks; see Figure 2.

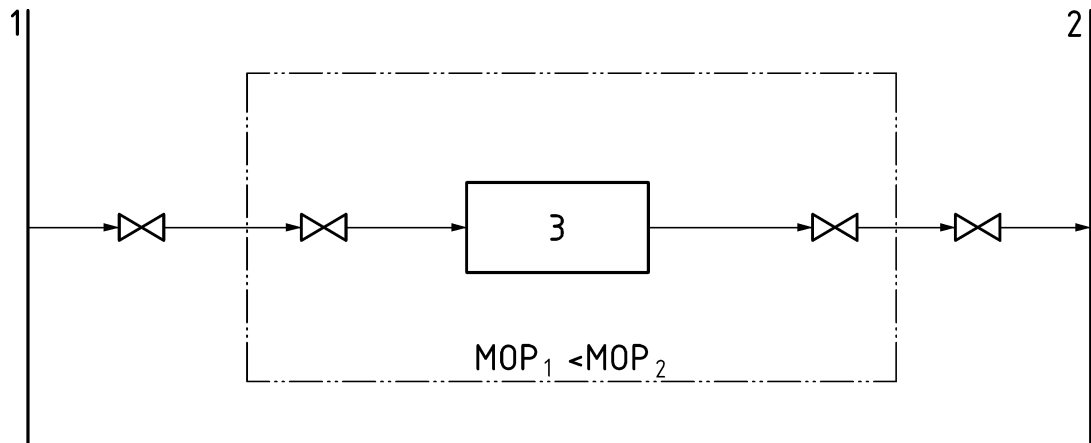
**Key**

- 1 downstream gas transmission or distribution network
- 2 upstream gas transmission or distribution network
- 3 refeeding station

**Figure 2 — Refeeding station**

This document represents the state of the art at the time of its preparation.

This document does not apply to injection stations operating prior to the publication of this document.

This document specifies common basic principles for gas infrastructure. Users of this document are expected to be aware that more detailed national standards and/or codes of practice can exist in the CEN member countries. This document is intended to be applied in association with these national standards and/or codes of practice setting out the above-mentioned basic principles.

In the event of terms of additional requirements in national legislation/regulation than in this document, CEN/TR 13737 (all parts) illustrates these terms.

CEN/TR 13737 (all parts) gives:

- legislation/regulations applicable in a member state;
- if appropriate, more restrictive national requirements;
- a national contact point for the latest information.



**EN 17928-1:2024 (E)****2 Normative references**

The following documents are referred to in the text in such a way that some or all of their content constitutes requirements of this document. For dated references, only the edition cited applies. For undated references, the latest edition of the referenced document (including any amendments) applies.

EN 1081, *Resilient, laminate and modular multilayer floor coverings — Determination of the electrical resistance*

EN 1594, *Gas infrastructure — Pipelines for maximum operating pressure over 16 bar — Functional requirements*

EN 1776, *Gas infrastructure — Gas measuring systems — Functional requirements*

EN 1998 (all parts), *Eurocode 8: Design of structures for earthquake resistance*

EN 10204, *Metallic products — Types of inspection documents*

EN 12007-1:2012, *Gas infrastructure — Pipelines for maximum operating pressure up to and including 16 bar — Part 1: General functional requirements*

EN 12186, *Gas infrastructure — Gas pressure regulating stations for transmission and distribution — Functional requirements*

EN 12405-1, *Gas meters — Conversion devices — Part 1: Volume conversion*

EN 12327, *Gas infrastructure — Pressure testing, commissioning and decommissioning procedures — Functional requirements*

EN 12732, *Gas infrastructure — Welding steel pipework — Functional requirements*

EN 13774, *Valves for gas distribution systems with maximum operating pressure less than or equal to 16 bar — Performance requirements*

EN 14141, *Valves for natural gas transportation in pipelines — Performance requirements and tests*

EN 14382, *Gas safety shut-off devices for inlet pressure up to 10 MPa (100 bar)*

EN 16723-1, *Natural gas and biomethane for use in transport and biomethane for injection in the natural gas network — Part 1: Specifications for biomethane for injection in the natural gas network*

EN 16726, *Gas infrastructure — Quality of gas — Group H*

EN 17649:2022, *Gas infrastructure — Safety Management System (SMS) and Pipeline Integrity Management System (PIMS) — Functional requirements*

EN 17928-2:2024, *Gas infrastructure — Injection stations — Part 2: Specific requirements regarding the injection of biomethane*

EN 17928-3:2024, *Gas infrastructure — Injection station — Part 3: Specific requirements regarding the injection of hydrogen*

CEN/TS 17977, *Gas infrastructure — Quality of gas — Hydrogen used in rededicated gas systems*

EN 60034-1, *Rotating electrical machines — Part 1: Rating and performance*

EN IEC 60079-10-1, *Explosive atmospheres — Part 10-1: Classification of areas — Explosive gas atmospheres*

EN 60079-14, *Explosive atmospheres — Part 14: Electrical installations design, selection and erection*

EN 60947-5-1, *Low-voltage switchgear and controlgear — Part 5-1: Control circuit devices and switching elements — Electromechanical control circuit devices*

EN 60204-1, *Safety of machinery — Electrical equipment of machines — Part 1: General requirements*

EN 61508-1, *Functional safety of electrical/electronic/programmable electronic safety-related systems — Part 1: General requirements*

EN 61511 (all parts), *Functional safety — Safety instrumented systems for the process industry sector*

EN 62305 (all parts), *Protection against lightning*

EN 62305-2, *Protection against lightning — Part 2: Risk management*

EN IEC 62443 (all parts), *Security for industrial automation and control systems*

HD 60364 (all parts), *Low-voltage electrical installations*

HD 60364-4-41, *Low-voltage electrical installations — Part 4-41: Protection for safety — Protection against electric shock*

HD 60364-5-54, *Low-voltage electrical installations — Part 5-54: Selection and erection of electrical equipment — Earthing arrangements and protective conductors*

EN ISO 10715, *Natural gas — Gas sampling (ISO 10715)*

EN ISO 12213 (all parts), *Natural gas — Calculation of compression factor (ISO 12213 (all parts))*

EN ISO 12944 (all parts), *Paints and varnishes — Corrosion protection of steel structures by protective paint systems (ISO 12944 (all parts))*

EN ISO 13849-1, *Safety of machinery — Safety-related parts of control systems — Part 1: General principles for design (ISO 13849-1)*

EN ISO/IEC 27001, *Information security, cybersecurity and privacy protection — Information security management systems — Requirements (ISO/IEC 27001)*

**koniec náhľadu – text ďalej pokračuje v platenej verzii STN**