

STN	Čistiarne odpadových vôd Časť 1: Všeobecné zásady navrhovania a výstavby	STN EN 12255-1 75 6410
------------	---	--

Wastewater treatment plants - Part 1: General design and construction principles

Táto norma obsahuje anglickú verziu európskej normy.
This standard includes the English version of the European Standard.

Táto norma bola oznámená vo Vestníku ÚNMS SR č. 01/25

Obsahuje: EN 12255-1:2024

Oznámením tejto normy sa ruší
STN EN 12255-1 (75 6410) zo septembra 2003

139926

Úrad pre normalizáciu, metrológiu a skúšobníctvo Slovenskej republiky, 2025
Slovenská technická norma a technická normalizačná informácia je chránená zákonom č. 60/2018 Z. z. o technickej normalizácii
v znení neskorších predpisov.

EUROPEAN STANDARD

EN 12255-1

NORME EUROPÉENNE

EUROPÄISCHE NORM

November 2024

ICS 13.060.30

Supersedes EN 12255-1:2002

English Version

Wastewater treatment plants - Part 1: General design and construction principles

Stations d'épuration - Partie 1 : Principes généraux de conception et de construction

Kläranlagen - Teil 1: Allgemeine Baugrundsätze

This European Standard was approved by CEN on 27 October 2024.

CEN members are bound to comply with the CEN/CENELEC Internal Regulations which stipulate the conditions for giving this European Standard the status of a national standard without any alteration. Up-to-date lists and bibliographical references concerning such national standards may be obtained on application to the CEN-CENELEC Management Centre or to any CEN member.

This European Standard exists in three official versions (English, French, German). A version in any other language made by translation under the responsibility of a CEN member into its own language and notified to the CEN-CENELEC Management Centre has the same status as the official versions.

CEN members are the national standards bodies of Austria, Belgium, Bulgaria, Croatia, Cyprus, Czech Republic, Denmark, Estonia, Finland, France, Germany, Greece, Hungary, Iceland, Ireland, Italy, Latvia, Lithuania, Luxembourg, Malta, Netherlands, Norway, Poland, Portugal, Republic of North Macedonia, Romania, Serbia, Slovakia, Slovenia, Spain, Sweden, Switzerland, Türkiye and United Kingdom.

EUROPEAN COMMITTEE FOR STANDARDIZATION
COMITÉ EUROPÉEN DE NORMALISATION
EUROPÄISCHES KOMITEE FÜR NORMUNG**CEN-CENELEC Management Centre: Rue de la Science 23, B-1040 Brussels**

EN 12255-1:2024 (E)

Contents	Page
European foreword	4
Introduction	6
1 Scope	8
2 Normative references	8
3 Terms and definitions	9
4 Abbreviated terms	11
5 Requirements	12
5.1 General requirements	12
5.2 Design requirements	13
5.2.1 Resilience	13
5.2.2 Safety and accessibility	14
5.2.3 Other design requirements	15
5.3 Modularity	16
5.4 Structural requirements	16
5.4.1 General	16
5.4.2 Dimensional tolerances	17
5.4.3 Concrete tracks for travelling mechanical equipment (e.g. Scraper Bridges)	17
5.4.4 Fixings and connections between equipment and structures	17
5.4.5 Safe access	17
5.4.6 Building ventilation	18
5.4.7 Water supply and drainage	18
5.4.8 Lifting equipment	18
5.4.9 Storage and conveyance of hazardous chemicals and fuels	18
5.5 Requirements for equipment	19
5.5.1 Principles for mechanical design	19
5.5.2 General design requirements	20
5.5.3 Environmental impact	23
5.5.4 Safety	24
5.5.5 Documentation	24
5.5.6 Spare parts, special tools	24
6 Test methods	25
6.1 Function and performance	25
6.2 Tightness testing of concrete structures	25
6.3 Tightness testing of other structures and equipment	25
7 Cost Comparison Analysis	25
Annex A (informative) Design Service Life	26
Annex B (normative) Structural tolerances	27
B.1 Circular tank	27
B.1.1 Circular clarifiers with scrapers	27
B.1.2 Circular tank with a scraper bridge travelling on the side wall (track)	27

B.1.3 Rectangular clarifiers with scrapers	27
Annex C (normative) Wall tracks	28
C.1 Tracks	28
C.2 Walls	28
C.3 Wheels	28
C.4 Freezing conditions	28
Annex D (normative) Scraper Design	29
D.1 Physical loads	29
D.2 Driver control	29
D.3 Bar and chain scrapers	29
D.4 Monitoring	30
D.5 Maintainability	30
D.6 Design life	30
Bibliography	31

EN 12255-1:2024 (E)**European foreword**

This document (EN 12255-1:2024) has been prepared by Technical Committee CEN/TC 165 “Waste water engineering”, the secretariat of which is held by DIN.

This European Standard shall be given the status of a national standard, either by publication of an identical text or by endorsement, at the latest by May 2025, and conflicting national standards shall be withdrawn at the latest by May 2025.

Attention is drawn to the possibility that some of the elements of this document may be the subject of patent rights. CEN shall not be held responsible for identifying any or all such patent rights.

This document supersedes EN 12255-1:2002.

The main changes compared to the previous edition are listed below:

- a) update of title and scope to incorporate design;
- b) comprehensive revision and additions in all sections;
- c) adaptation to the current state of the art;
- d) updating of the Normative references;
- e) editorial revision.

This is the first part prepared by Working Group CEN/TC 165/WG 40 relating to the general requirements and processes for treatment plants for a total number of inhabitants and population equivalents (PT) over 50.

The EN 12255 series with the generic title “*Wastewater treatment plants*” consists of the following parts:

- *Part 1: General design and construction principles*
- *Part 2¹: Storm management systems*
- *Part 3: Preliminary treatment*
- *Part 4: Primary treatment*
- *Part 5: Lagooning processes*
- *Part 6: Activated sludge process*
- *Part 7: Biological fixed-film reactors*
- *Part 8: Sludge treatment and storage*
- *Part 9: Odour control and ventilation*
- *Part 10: Safety principles*

¹ Part 2 is under preparation.

- *Part 11: General data required*
- *Part 12: Control and automation*
- *Part 13: Chemical treatment — Treatment of wastewater by precipitation/flocculation*
- *Part 14: Disinfection*
- *Part 15: Measurement of the oxygen transfer in clean water in aeration tanks of activated sludge plants*
- *Part 16: Physical (mechanical) filtration*

Any feedback and questions on this document should be directed to the users' national standards body. A complete listing of these bodies can be found on the CEN website.

According to the CEN-CENELEC Internal Regulations, the national standards organisations of the following countries are bound to implement this European Standard: Austria, Belgium, Bulgaria, Croatia, Cyprus, Czech Republic, Denmark, Estonia, Finland, France, Germany, Greece, Hungary, Iceland, Ireland, Italy, Latvia, Lithuania, Luxembourg, Malta, Netherlands, Norway, Poland, Portugal, Republic of North Macedonia, Romania, Serbia, Slovakia, Slovenia, Spain, Sweden, Switzerland, Türkiye and the United Kingdom.

EN 12255-1:2024 (E)**Introduction**

Differences in wastewater treatment throughout Europe have led to a variety of systems being developed. This document gives fundamental information about the systems; this document has not attempted to specify all available systems. A generic arrangement of wastewater treatment plants is illustrated in Figure 1.

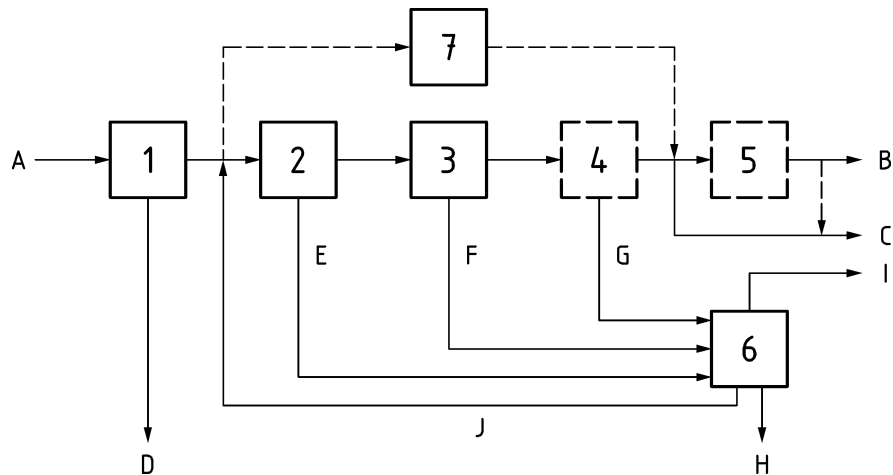
**Key**

- 1 preliminary treatment
- 2 primary treatment
- 3 secondary treatment
- 4 tertiary treatment
- 5 additional treatment (e.g. disinfection or removal of micropollutants)
- 6 sludge treatment
- 7 lagoons (as an alternative)
- A raw wastewater
- B effluent for re-use (e.g. irrigation)
- C discharged effluent
- D screenings and grit
- E primary sludge
- F secondary sludge
- G tertiary sludge
- H digested sludge
- I digester gas
- J returned water from dewatering

Figure 1 — Schematic diagram of wastewater treatment plants

The primary application is for wastewater treatment plants designed for the treatment of domestic and municipal wastewater.

NOTE For requirements on pumping installations at wastewater treatment plants see EN 752, *Drain and sewer systems outside buildings* and the EN 16932 series, *Drain and sewer systems outside buildings — Pumping systems*:

- Part 1: General requirements;
- Part 2: Positive pressure systems;
- Part 3: Vacuum systems.

EN 12255-1:2024 (E)**1 Scope**

This document specifies the basic design and construction requirements for wastewater treatment plants for over 50 PT.

NOTE 1 Requirements for structures which are not specific for wastewater treatment plants are not within the scope of this document. Other ENs can apply.

NOTE 2 Equipment which is not solely used in wastewater treatment plants is subject to the applicable product standards. However, specific requirements for such equipment when used in wastewater treatment plants are included in this part.

NOTE 3 Although this document specifies the basic design and construction requirements for wastewater treatment plants for over 50 PT, many requirements are only technically and economically feasible at significantly larger sizes.

2 Normative references

The following documents are referred to in the text in such a way that some or all of their content constitutes requirements of this document. For dated references, only the edition cited applies. For undated references, the latest edition of the referenced document (including any amendments) applies.

EN 809, *Pumps and pump units for liquids — Common safety requirements*

EN 10088-2, *Stainless steels — Part 2: Technical delivery conditions for sheet/plate and strip of corrosion resisting steels for general purposes*

EN 12255-9, *Wastewater treatment plants — Part 9: Odour control and ventilation*

EN 12255-10, *Wastewater treatment plants — Part 10: Safety principles*

EN 12255-13, *Wastewater treatment plants — Part 13: Chemical treatment - Treatment of wastewater by precipitation/flocculation*

EN 16323, *Glossary of wastewater engineering terms*

EN 16932 (all parts), *Drain and sewer systems outside buildings — Pumping systems*

EN 60529, *Degrees of protection provided by enclosures (IP Code) (IEC 60529)*

EN 60034-1, *Rotating electrical machines — Part 1: Rating and performance (IEC 60034-1)*

EN ISO 3506-1, *Fasteners — Mechanical properties of corrosion-resistant stainless steel fasteners — Part 1: Bolts, screws and studs with specified grades and property classes (ISO 3506-1)*

EN ISO 3506-2, *Fasteners — Mechanical properties of corrosion-resistant stainless steel fasteners — Part 2: Nuts with specified grades and property classes (ISO 3506-2)*

EN ISO 14122-2:2016, *Safety of machinery — Permanent means of access to machinery — Part 2: Working platforms and walkways (ISO 14122-2:2016)*

ISO 4200, *Plain end steel tubes, welded and seamless — General tables of dimensions and masses per unit length*

koniec náhľadu – text ďalej pokračuje v platenej verzii STN