

STN	Plynárenská infraštruktúra Kompresorové stanice Požiadavky na prevádzku	STN EN 12583+A1 38 6481
------------	--	---

Gas Infrastructure - Compressor stations - Functional requirements

Táto norma obsahuje anglickú verziu európskej normy.
This standard includes the English version of the European Standard.

Táto norma bola oznámená vo Vestníku ÚNMS SR č. 01/25

Obsahuje: EN 12583:2022+A1:2024

Oznámením tejto normy sa ruší
STN EN 12583 (38 6481) z augusta 2022

140071

Úrad pre normalizáciu, metrológiu a skúšobníctvo Slovenskej republiky, 2025
Slovenská technická norma a technická normalizačná informácia je chránená zákonom č. 60/2018 Z. z. o technickej normalizácii
v znení neskorších predpisov.

EUROPEAN STANDARD

EN 12583:2022+A1

NORME EUROPÉENNE

EUROPÄISCHE NORM

November 2024

ICS 23.140; 75.200

Supersedes EN 12583:2022

English Version

Gas Infrastructure - Compressor stations - Functional requirements

Infrastructures gazières - Stations de compression -
Prescriptions fonctionnellesGasinfrastruktur - Verdichterstationen - Funktionale
Anforderungen

This European Standard was approved by CEN on 20 March 2022 and includes Amendment 1 approved by CEN on 25 July 2024.

CEN members are bound to comply with the CEN/CENELEC Internal Regulations which stipulate the conditions for giving this European Standard the status of a national standard without any alteration. Up-to-date lists and bibliographical references concerning such national standards may be obtained on application to the CEN-CENELEC Management Centre or to any CEN member.

This European Standard exists in three official versions (English, French, German). A version in any other language made by translation under the responsibility of a CEN member into its own language and notified to the CEN-CENELEC Management Centre has the same status as the official versions.

CEN members are the national standards bodies of Austria, Belgium, Bulgaria, Croatia, Cyprus, Czech Republic, Denmark, Estonia, Finland, France, Germany, Greece, Hungary, Iceland, Ireland, Italy, Latvia, Lithuania, Luxembourg, Malta, Netherlands, Norway, Poland, Portugal, Republic of North Macedonia, Romania, Serbia, Slovakia, Slovenia, Spain, Sweden, Switzerland, Türkiye and United Kingdom.

EUROPEAN COMMITTEE FOR STANDARDIZATION
COMITÉ EUROPÉEN DE NORMALISATION
EUROPÄISCHES KOMITEE FÜR NORMUNG**CEN-CENELEC Management Centre: Rue de la Science 23, B-1040 Brussels**

EN 12583:2022+A1:2024 (E)

Contents	Page
European foreword	5
1 Scope	7
2 Normative references	8
3 Terms and definitions	9
4 Safety	16
5 Asset management and quality assurance	16
6 Environmental constraints	17
6.1 General.....	17
6.2 NO _x and CO determination.....	17
6.2.1 General.....	17
6.2.2 Periodic measurements.....	17
6.2.3 Continuous Emission Monitoring System (CEMS).....	17
6.2.4 Predictive Emission Monitoring System (PEMS)	17
6.3 Methane emission management.....	18
6.3.1 General.....	18
6.3.2 Design phase.....	18
6.3.3 Construction, commissioning and decommissioning.....	19
6.3.4 Operation and maintenance	19
7 Design, construction	19
7.1 General requirements for design.....	19
7.1.1 General.....	19
7.1.2 Safety and the environment.....	20
7.2 Location and station lay-out	21
7.2.1 Location.....	21
7.2.2 Station lay-out.....	21
7.3 Pipework.....	23
7.3.1 Design considerations.....	23
7.3.2 Gas Valves	23
7.3.3 Gas cleaning	23
7.3.4 Gas coolers.....	24
7.3.5 Pressure reduction stations.....	24
7.3.6 Recycle line	24
7.3.7 Vent systems.....	24
7.3.8 Station isolation system	24
7.3.9 Corrosion protection	24
7.3.10 Services pipework	25
7.3.11 Standard colour code.....	25
7.4 Compressor unit.....	25
7.4.1 General.....	25
7.4.2 Driver	25
7.4.3 Compressor	26
7.4.4 Unit Control System (UCS)	27
7.4.5 Unit auxiliary equipment.....	31
7.4.6 Foundations	35
7.4.7 Compressor unit housing.....	35
7.5 Station control and automation.....	36

7.5.1	Station Control System (SCS)	36
7.5.2	Station emergency shutdown systems	36
7.5.3	Gas detection system	37
7.5.4	Fire protection system	37
7.5.5	Station valve control and supervision	37
7.5.6	Over-pressure protection system	37
7.5.7	Over-temperature protection system	38
7.6	Electrical installation and power supply	38
7.6.1	General	38
7.6.2	Electrical power supply	38
7.6.3	Electrical installation	38
7.6.4	Illumination requirements	38
7.7	General requirements for construction	39
7.7.1	General	39
7.7.2	Execution of work	39
7.7.3	Station pipework construction	39
8	Testing, commissioning and acceptance	39
8.1	General requirements	39
8.2	Pre-commissioning	39
8.3	Commissioning	39
8.4	As built records of the station	40
8.5	Handover	40
8.6	Responsibility for safety	40
9	Operation	41
9.1	Introduction and basic requirements	41
9.2	Operating organization	41
9.3	Instruction procedures	41
9.3.1	General	41
9.3.2	Instructions for normal situations	41
9.3.3	Instructions for failure or emergency situations	42
9.3.4	Procedures for specific planned situations	42
9.4	Management of operating procedures	43
9.5	Training of personnel	43
9.6	Safety precautions	43
9.6.1	Prevention of gas explosion and fire	43
9.6.2	Storage of combustible materials	43
9.6.3	Venting	44
9.6.4	IT-Security	44
10	Maintenance	44
10.1	Introduction and basic requirements	44
10.2	Maintenance organization	44
10.3	Maintenance procedures	45
10.3.1	General	45
10.3.2	Gas compressor units	45
10.3.3	Pipework	45
10.4	Management of the maintenance procedures	46
10.5	Training of personnel	46
10.6	Maintenance tools and equipment	46
10.7	Safety	46
10.7.1	General	46
10.7.2	Safety precautions	47
10.7.3	Safety devices	47

EN 12583:2022+A1:2024 (E)

11	Decommissioning and disposal	48
11.1	Decommissioning	48
11.2	Disposal	48
	Annex A (informative) Boundary of a gas compressor station	49
	Annex B (informative) Parts of a gas compressor unit	51
	Annex C (informative) Boundary Gas compressor unit — Driver package	52
	Annex D (informative) Boundary Gas compressor unit — Gas compressor	53
	Annex E (informative) Boundary Gas compressor unit — Unit control system	54
	Annex F (informative) Boundary Gas compressor unit — Auxiliary equipment	55
	Annex G (normative) Applicable measurement systems for NO_x and CO determination	56
	Annex H (informative) Examples of PEMS and quality insurance applications	58
H.1	Predictive Emission Monitoring System (PEMS), a relational model: quality criteria implementation:	58
H.1.1	General	58
H.1.2	QAL 1, design part	58
H.1.3	QAL 2 calibration and functional test (installation)	60
H.1.4	QAL 3, drift and precision control in operation	60
H.1.5	AST Annual Survey Test	60
H.2	An example of a polynomial model for PEMS for gas fired conventional turbines / engines:	60
	Annex I (informative) Categories of methane emissions	62
	Bibliography	63

European foreword

This document (EN 12583:2022+A1:2024) has been prepared by Technical Committee CEN/TC 234 “Gas infrastructure”, the secretariat of which is held by DIN.

This European Standard shall be given the status of a national standard, either by publication of an identical text or by endorsement, at the latest by May 2025, and conflicting national standards shall be withdrawn at the latest by May 2025.

Attention is drawn to the possibility that some of the elements of this document may be the subject of patent rights. CEN shall not be held responsible for identifying any or all such patent rights.

This document includes Amendment 1 approved by CEN on 25 July 2024.

This document supersedes A1 EN 12583:2022 A1.

The start and finish of text introduced or altered by amendment is indicated in the text by tags A1 A1.

A1 *deleted text* A1

This document has been prepared under a Standardization Request given to CEN by the European Commission and the European Free Trade Association.

There is a complete suite of functional standards prepared by CEN/TC 234 “Gas infrastructure” to cover all parts of the gas infrastructure from the input of gas into the onshore transmission network up to the inlet connection of gas appliances, including including A1 injection, transmission, compression, pressure control, storage, blending, gas treatment, odourisation, distribution, measuring, and associated installation pipework, as well as related requirements such as safety, gas quality, sustainability, environment and emissions. Within the scope of CEN/TC 234, gaseous energy carriers and blends describe gases which are in the gaseous state when conveyed in the gas pipeline infrastructure such as hydrogen, hydrogen rich, and methane rich gases, dimethyl ether (DME) and propane and butanes used for combustion and/or as feedstock, excluding steam and compressed air. A1 In preparing this document a basic understanding of gas infrastructure by the user has been assumed.

The gas infrastructure is complex and the importance on safety of its construction and use has led to the development of very detailed codes of practice and operating manuals in the member countries. These detailed statements embrace recognized standards of gas engineering and the specific requirements imposed by the legal structures of the member countries.

A1 Directive (EU) 2024/1788 A1 concerning common rules for the internal market in natural gas and the related Regulation A1 (EU) 2024/1789 A1 on conditions for access to the natural gas transmission networks also aim at technical safety (security) including technical reliability of the European gas system. These aspects are also in the scope of CEN/TC 234 standardization. In this respect CEN/TC 234 evaluated the indicated EU legislation and amended this document accordingly, where required and appropriate.

In this edition of EN 12583 environmental aspects relevant to the design, construction and testing, operation and maintenance, decommissioning and disposal of compressor stations in the scope of this document are covered in accordance with CEN Guide 4 and CEN/TR 16388.

EN 12583:2022+A1:2024 (E)

Directive [\[A1\]](#) (EU) 2018/2001, Articles 3 and 7 [\[A1\]](#) are with regard to the calculation of the share of energy from renewable sources and the contribution of hydrogen originating from renewable sources in the total fuel mix. In this respect CEN/TC 234 evaluated the indicated EU legislation and amended this document.

Any feedback and questions on this document should be directed to the users' national standards body. A complete listing of these bodies can be found on the CEN website.

According to the CEN-CENELEC Internal Regulations, the national standards organisations of the following countries are bound to implement this European Standard: Austria, Belgium, Bulgaria, Croatia, Cyprus, Czech Republic, Denmark, Estonia, Finland, France, Germany, Greece, Hungary, Iceland, Ireland, Italy, Latvia, Lithuania, Luxembourg, Malta, Netherlands, Norway, Poland, Portugal, Republic of North Macedonia, Romania, Serbia, Slovakia, Slovenia, Spain, Sweden, Switzerland, Turkey and the United Kingdom.

1 Scope

This document describes the specific functional requirements for the design, construction, operation, maintenance and disposal activities for safe and secure gas compressor stations.

This document applies to new gas compressor stations with a Maximum Operating Pressure (MOP) over 16 bar and with a total shaft power over 1 MW. For existing compressor stations, this document applies to new compressor units. Where changes/modifications to existing installations or gas composition take place, due account can be taken of the requirements of this document.

This document does not apply to gas compressor stations or compressor units operating prior to the publication of this document. For existing sites this document can be used as guidance.

The purpose of this document is to:

- ensure the health and safety of the public and all site personnel;
- cover environmental issues;
- avoid incidental damage to nearby property; and
- open the gas infrastructure to accommodate renewable gases, including a possible design for hydrogen.

This document specifies common basic principles for the gas infrastructure. Users of this document are expected to be aware that more detailed national standards and/or codes of practice can exist in the CEN member countries.

This document is intended to be applied in association with these national standards and/or codes of practice setting out the above-mentioned basic principles.

In the event of conflicts in terms of more restrictive requirements in national legislation/regulation with the requirements of this document, the national legislation/regulation takes precedence as illustrated in CEN/TR 13737 (all parts). CEN/TR 13737 (all parts) gives:

- clarification of all legislations/regulations applicable in a member state;
- if appropriate, more restrictive national requirements;
- a national contact point for the latest information.

This document does not apply to:

- off-shore gas compressor stations;
- gas compressor stations for compressed gas filling-stations;
- customer installations downstream of the point of custody transfer;
- design and construction of driver packages (see Annex C);
- mobile compressor equipment.

For supplies to utility services such as small central heating boilers reference is made to EN 1775.

Figure 1 shows a schematic representation of compressor stations in a gas infrastructure. For further information refer to Annexes A, B, C, D, E and F.

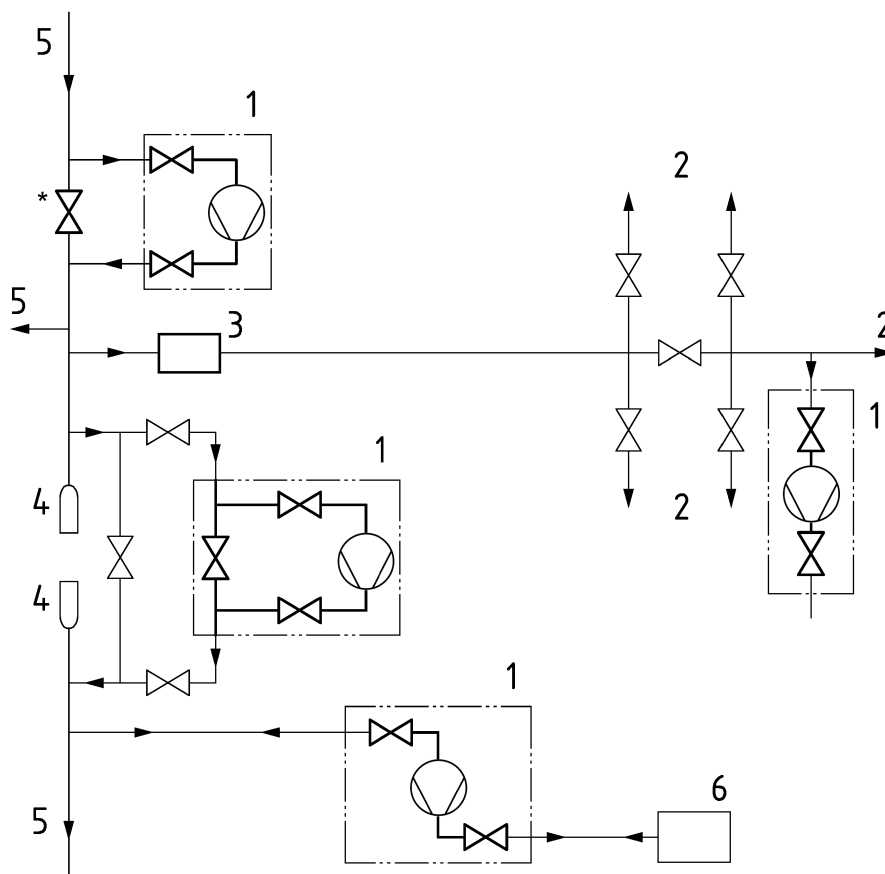
EN 12583:2022+A1:2024 (E)**Key**

- | | | | |
|---|---|---|-------------------|
| 1 | compressor station | 4 | pig traps |
| 2 | distribution system | 5 | transmission line |
| 3 | metering and/or pressure limiting or regulation station | 6 | storage facility |
| * | part of pipeline but operated by safety control systems | | |

NOTE Parts indicated in frames by thick lines are within the scope of this document.

Figure 1 — Schematic representation of compressor stations in the gas infrastructure

2 Normative references

The following documents are referred to in the text in such a way that some or all of their content constitutes requirements of this document. For dated references, only the edition cited applies. For undated references, the latest edition of the referenced document (including any amendments) applies.

EN 1012-3, *Compressors and vacuum pumps - Safety requirements - Part 3: Process compressors*

EN 14181, *Stationary source emissions - Quality assurance of automated measuring systems*

EN 1594, *Gas infrastructure - Pipelines for maximum operating pressure over 16 bar - Functional requirements*

EN 12186, *Gas infrastructure - Gas pressure regulating stations for transmission and distribution - Functional requirements*

EN 12266-1, *Industrial valves - Testing of metallic valves - Part 1: Pressure tests, test procedures and acceptance criteria - Mandatory requirements*

EN 12266-2, *Industrial valves - Testing of metallic valves - Part 2: Tests, test procedures and acceptance criteria - Supplementary requirements*

EN 12732, *Gas infrastructure — Welding steel pipework — Functional requirements*

EN 14505, *Cathodic protection of complex structures*

EN 60079-20-1, *Explosive atmospheres — Part 20-1: Material characteristics for gas and vapour classification — Test methods and data*

EN IEC 61000-6-2, *Electromagnetic compatibility (EMC) - Part 6-2: Generic standards - Immunity standard for industrial environments*

EN 61000-6-4, *Electromagnetic compatibility (EMC) - Part 6-4: Generic standards - Emission standard for industrial environments*

EN 61508 (all parts), *Functional safety of electrical/electronic/programmable electronic safety-related systems*

EN 61511 (all parts), *Functional safety - Safety instrumented systems for the process industry sector*

EN ISO 10437, *Petroleum, petrochemical and natural gas industries - Steam turbines - Special-purpose applications (ISO 10437)*

EN ISO 10439 (all parts), *Petroleum, chemical and gas service industries - Axial and centrifugal compressors and expander-compressors - Part 4: Expander-compressors (ISO 10439)*

EN ISO 13849-1, *Safety of machinery - Safety-related parts of control systems - Part 1: General principles for design (ISO 13849-1)*

ISO 3977-1, *Gas turbines — Procurement — Part 1: General introduction and definitions*

ISO 3977-2, *Gas turbines — Procurement — Part 2: Standard reference conditions and ratings*

ISO 13707, *Petroleum and natural gas industries — Reciprocating compressors*

koniec náhľadu – text ďalej pokračuje v platenej verzii STN