

STN	Zariadenia na zníženie hluku z cestnej dopravy Skúšobná metóda na určovanie akustických vlastností Časť 2: Vlastné charakteristiky Vzduchová nepriezvučnosť v podmienkach rozptýleného zvukového poľa	STN EN 1793-2 73 6041
------------	--	---

Road traffic noise reducing devices - Test method for determining the acoustic performance - Part 2: Intrinsic characteristics - Airborne sound insulation under diffuse sound field conditions

Táto norma obsahuje anglickú verziu európskej normy.
This standard includes the English version of the European Standard.

Táto norma bola oznámená vo Vestníku ÚNMS SR č. 03/26

Obsahuje: EN 1793-2:2025

Oznámením tejto normy sa ruší
STN EN 1793-2 (73 6041) z januára 2019

142264



EUROPEAN STANDARD

EN 1793-2

NORME EUROPÉENNE

EUROPÄISCHE NORM

December 2025

ICS 17.140.30; 93.080.30

Supersedes EN 1793-2:2018

English Version

Road traffic noise reducing devices - Test method for determining the acoustic performance - Part 2: Intrinsic characteristics - Airborne sound insulation under diffuse sound field conditions

Dispositifs de réduction du bruit du trafic routier -
Méthode d'essai pour la détermination de la
performance acoustique - Partie 2: Caractéristiques
intrinsèques - Isolation au bruit aérien dans des
conditions de champ acoustique diffus

Lärmschutzvorrichtungen an Straßen - Prüfverfahren
zur Bestimmung der akustischen Eigenschaften - Teil
2: Produktspezifische Merkmale - Luftschalldämmung
unter den Bedingungen eines diffusen Schallfeldes

This European Standard was approved by CEN on 17 November 2025.

CEN members are bound to comply with the CEN/CENELEC Internal Regulations which stipulate the conditions for giving this European Standard the status of a national standard without any alteration. Up-to-date lists and bibliographical references concerning such national standards may be obtained on application to the CEN-CENELEC Management Centre or to any CEN member.

This European Standard exists in three official versions (English, French, German). A version in any other language made by translation under the responsibility of a CEN member into its own language and notified to the CEN-CENELEC Management Centre has the same status as the official versions.

CEN members are the national standards bodies of Austria, Belgium, Bulgaria, Croatia, Cyprus, Czech Republic, Denmark, Estonia, Finland, France, Germany, Greece, Hungary, Iceland, Ireland, Italy, Latvia, Lithuania, Luxembourg, Malta, Netherlands, Norway, Poland, Portugal, Republic of North Macedonia, Romania, Serbia, Slovakia, Slovenia, Spain, Sweden, Switzerland, Türkiye and United Kingdom.



EUROPEAN COMMITTEE FOR STANDARDIZATION
COMITÉ EUROPÉEN DE NORMALISATION
EUROPÄISCHES KOMITEE FÜR NORMUNG

CEN-CENELEC Management Centre: Rue de la Science 23, B-1040 Brussels

EN 1793-2:2025 (E)

Contents		Page
European foreword		3
Introduction		5
1	Scope	7
2	Normative references	7
3	Terms and definitions	7
4	Symbols and abbreviations	8
5	Test specimen arrangement	9
6	Test procedure and evaluation	11
6.1	Test method	11
6.2	Single-number rating of airborne sound insulation, DL_R	11
6.3	Expression of results	11
7	Measurement uncertainty	11
8	Test report	12
Annex A (informative) Guidance note on the use of the single-number rating DL_R		13
Annex B (normative) Measurement uncertainty		14
Annex C (normative) Test report template		16
Bibliography		22

European foreword

This document (EN 1793-2:2025) has been prepared by Technical Committee CEN/TC 226 “Road equipment”, the secretariat of which is held by AFNOR.

This European Standard shall be given the status of a national standard, either by publication of an identical text or by endorsement, at the latest by June 2026, and conflicting national standards shall be withdrawn at the latest by June 2026.

Attention is drawn to the possibility that some of the elements of this document may be the subject of patent rights. CEN shall not be held responsible for identifying any or all such patent rights.

This document supersedes EN 1793-2:2018.

EN 1793-2:2025 includes the following significant technical changes with respect to EN 1793-2:2018:

- the title has been slightly changed;
- the declaration of measurement uncertainty and the related confidence level is now mandatory;
- the categories of single-number rating have been removed. Prior Annex A has been deleted. The performance of the noise reducing device is, from now on, only to be reported in terms of the numeric values of the single-number rating;
- an annex with the values of the standard deviation of reproducibility and repeatability has been added; this makes possible the declaration of the measurement uncertainty and the related confidence level, which is now mandatory (Annex B);
- a detailed example has been added, including the declaration of the uncertainty (Annex C).

The EN 1793 series, under the general title *Road traffic noise reducing devices — Test method for determining the acoustic performance*, consists of the following parts:

- *Part 1: Intrinsic characteristics — Sound absorption under diffuse sound field conditions;*
- *Part 2: Intrinsic characteristics — Airborne sound insulation under diffuse sound field conditions;*
- *Part 3: Normalized traffic noise spectrum;*
- *Part 4: Intrinsic characteristics — Intrinsic sound diffraction;*
- *Part 5: Intrinsic characteristics — Sound absorption under direct sound field conditions;*
- *Part 6: Intrinsic characteristics — Airborne sound insulation under direct sound field conditions.*

Any feedback and questions on this document should be directed to the users’ national standards body. A complete listing of these bodies can be found on the CEN website.

According to the CEN-CENELEC Internal Regulations, the national standards organisations of the following countries are bound to implement this European Standard: Austria, Belgium, Bulgaria, Croatia, Cyprus, Czech Republic, Denmark, Estonia, Finland, France, Germany, Greece, Hungary, Iceland, Ireland, Italy, Latvia, Lithuania, Luxembourg, Malta, Netherlands, Norway, Poland, Portugal, Republic of

EN 1793-2:2025 (E)

North Macedonia, Romania, Serbia, Slovakia, Slovenia, Spain, Sweden, Switzerland, Türkiye and the United Kingdom.

Introduction

Noise reducing devices alongside roads should provide adequate sound insulation so that sound transmitted through the road traffic noise reducing devices is not significant compared with the sound diffracted over the top. This document specifies a test method for qualifying the intrinsic airborne sound insulation performance for noise reducing devices designed for roads in reverberant conditions, e.g. inside tunnels or deep trenches or under covers.

The measurement results of this method for airborne sound insulation are comparable but not identical with the results of the test method EN 1793-6:2025 [5], mainly because the present method uses a diffuse sound field, while the other method assumes a directional sound field. Research studies suggest that good correlation exists between field data, measured according to EN 1793-6:2025 and laboratory data, measured according to the method described in the present document [1], [2], [3], [4].

This document does not apply to the determination of the insertion loss (extrinsic performance), which additionally depends on factors which are not related to the product itself; e.g. the dimensions of the barrier and quality of installation work and site factors such as ground impedance, site geometry, etc. The test is designed to allow the intrinsic airborne sound insulation performance of the road traffic noise reducing device to be measured; the resulting rating should aid the selection of devices for reverberant roadside applications.

For the purpose of this document, reverberant conditions are defined based on the geometric envelope, e , across the road formed by the barriers, trench sides or buildings (the envelope does not include the road surface) as shown by the dashed lines in Figure 1. Conditions are defined as being reverberant when the percentage of open space in the envelope is less than or equal to 25 %, i.e. reverberant conditions occur when $w/e \leq 0,25$, where $e = (w+h_1+h_2)$.

This method may be used to qualify noise reducing devices for other applications, e.g. to be installed near industrial sites. In this case, the single-number ratings can preferably be calculated using an appropriate spectrum.

EN 1793-2:2025 (E)

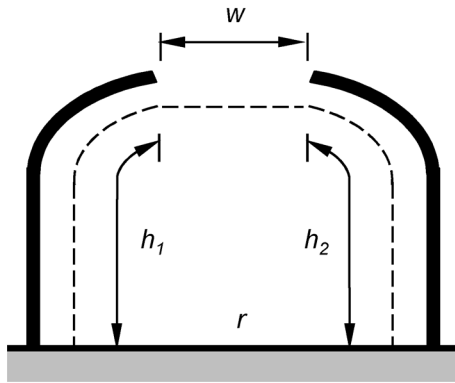

a) Partial cover on both sides of the road;
geometric envelope, $e = w + h_1 + h_2$

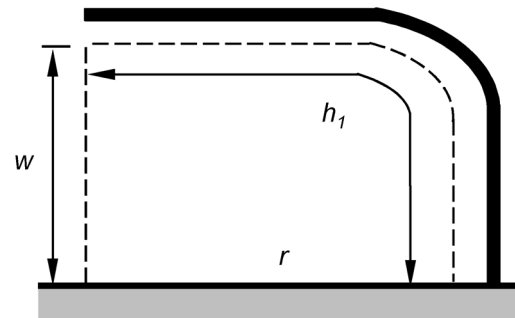

b) Partial cover on one side of the road;
geometric envelope, $e = w + h_1$; $h_2 = 0$

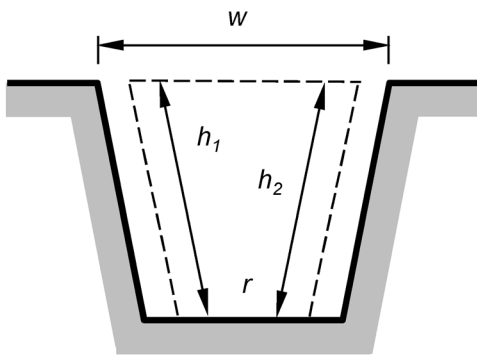

c) Deep trench;
geometric envelope, $e = w + h_1 + h_2$

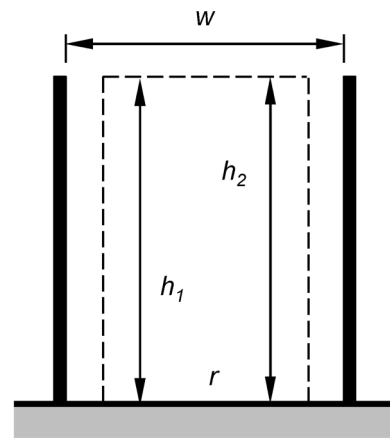

d) Tall barriers or buildings;
geometric envelope, $e = w + h_1 + h_2$

Key

r road surface

w width of open space

h_1 developed length of the construction, e.g. cover, trench side, barrier or building

h_2 developed length of the construction, e.g. cover, trench side, barrier or building

NOTE Figure 1 is not to scale.

Figure 1 — Sketch of the reverberant condition check in four cases

1 Scope

This document specifies the laboratory method for measuring the airborne sound insulation performance of road traffic noise reducing devices in reverberant conditions. It covers the assessment of the intrinsic performance of barriers that can reasonably be assembled inside the testing facility described in EN ISO 10140-2 and EN ISO 10140-4.

This method is not intended for the determination of the intrinsic characteristics of airborne sound insulation of noise reducing devices to be installed on roads in non-reverberant conditions.

2 Normative references

The following documents are referred to in the text in such a way that some or all of their content constitutes requirements of this document. For dated references, only the edition cited applies. For undated references, the latest edition of the referenced document (including any amendments) applies.

EN 1793-3:2025, *Road traffic noise reducing devices — Test method for determining the acoustic performance — Part 3: Normalized traffic noise spectrum*

EN ISO 10140-1:2021, *Acoustics — Laboratory measurement of sound insulation of building elements — Part 1: Application rules for specific products (ISO 10140-1:2021)*

EN ISO 10140-2:2021, *Acoustics — Laboratory measurement of sound insulation of building elements — Part 2: Measurement of airborne sound insulation (ISO 10140-2:2021)*

EN ISO 10140-4:2021, *Acoustics — Laboratory measurement of sound insulation of building elements — Part 4: Measurement procedures and requirements (ISO 10140-4:2021)*

ISO/IEC Guide 98-3:2008, *Uncertainty of measurement — Part 3: Guide to the expression of uncertainty in measurement (GUM:1995)*

koniec náhľadu – text ďalej pokračuje v platenej verzii STN